



www.Berner.com

Architectural Icon Air Curtain Series #AI08 & AI10

WHEN THE DOORS ARE OPEN™ save energy & create healthy, comfortable environments



Connect with
BERNER AIR

- ▶ SET UP
- ▶ CONTROL
- ▶ TROUBLESHOOT

BERNER.COM

Installation & Maintenance Instructions

TABLE OF CONTENTS

I. UNCRATING.....	2
II. GENERAL MOUNTING INSTRUCTIONS	4
III. WALL MOUNTING	5
IV. SUSPENDED MOUNTING	5
V. ELECTRICAL CONNECTIONS	5
VI. FIELD CONNECTIONS	6
VII. OPERATING INSTRUCTIONS (Intelliswitch™, Berner AIR™, BACnet)	7
INTELLISWITCH™ QUICK START OPERATION.....	10
FAQ's (FREQUENTLY ASKED QUESTIONS)	12
VIII. MAINTENANCE AND CLEANING.....	8
IX. SERVICE	8
X. TROUBLESHOOTING	14
XI. APPENDIX	
A. SERIAL NETWORK CONNECTION	15
B. WALL MOUNTED TOUCHSCREEN	15
C. BACnet-IP INTEGRATION	15
XII.WARRANTY	16

Thank you for choosing Berner.

Berner International has been saving energy and creating healthy, comfortable environments for our customers for over 60 years. Berner offers unmatched quality, performance, and dependability—not to mention our service. At Berner, we stand behind our products.



READ ALL INSTRUCTIONS BEFORE INSTALLING OR USING AIR CURTAIN

II-280D
June, 2023

WARNING: TO REDUCE THE RISK OF FIRE, ELECTRIC SHOCK OR INJURY TO PERSONS, OBSERVE THE FOLLOWING:

- A. Read all instructions before installing or using this air curtain.
- B. Use this unit only in the manner intended by the manufacturer and described in this manual. Any other use not recommended by the manufacturer may cause fire, electric shock, or injury to persons. If you have any questions, contact the manufacturer.
- C. Before servicing or cleaning unit, switch power off at service panel and lock the service disconnecting means to prevent power from being switched on accidentally. When the service disconnecting means cannot be locked, securely fasten a prominent warning device, such as a tag, to the service panel.
- D. Installation work and electrical wiring must be done by qualified person(s) in accordance with all applicable national and local codes having jurisdiction, including fire-rated construction. See page 5, ELECTRICAL CONNECTIONS (NEC Code ANSI/NFPA No. 70).
- E. When cutting or drilling into wall or ceiling, do not damage electrical wiring and other hidden utilities.
- F. To reduce the risk of fire, do not store or use gasoline or other flammable vapors and liquids in the vicinity of the air curtain.
- G. This air curtain is hot when in use. To avoid burns, do not let bare skin touch hot surfaces. Keep combustible materials, such as furniture, pillows, bedding, papers, clothes, etc. and curtains at least 1 inch from the top, back, front, sides and at least 6 feet from the discharge of the air curtain.
- H. Extreme caution is necessary when any air curtain is used by or near children or invalids, and whenever the heater is left operating unattended.
- I. Do not operate any air curtain after it malfunctions. Disconnect power at the service panel and have the air curtain inspected by a reputable electrician before reusing.
- J. To disconnect the air curtain, turn controls to "off", and turn off power to the air curtain circuit at main disconnect panel.
- K. Do not insert or allow foreign objects to enter any ventilation or discharge opening as this may cause an electric shock or fire, or damage the air curtain.
- L. To prevent a possible fire, do not block the air intake or discharge of the air curtain in any manner.
- M. The air curtain has hot and arcing or sparking parts inside. Do not use it in areas where gasoline, paint, or flammable vapors or liquids are used or stored.
- N. This heater may include an audible or visual alarm to warn that parts of the heater are getting excessively hot. If the alarm sounds (or illuminates), immediately turn the heater off and inspect for any objects on or adjacent to the heater that may have blocked the airflow or otherwise caused high temperatures to have occurred. **DO NOT OPERATE THE HEATER WITH THE ALARM SOUNDING (OR ILLUMINATING).**



Model: AI08

For mounting heights up to 8'



Model: AI10

For mounting heights up to 10'

I. UNCRATING

Carefully examine the carton(s) for damage. If the carton is damaged, immediately notify the shipping company. **Do not delay in filing a claim.** If the air curtain(s) were shipped on wooden skids, remove protective wood and banding straps securing the carton(s) to the skid. Open the carton(s) and remove all protective packaging.

Locate the wall mounting plates. Shorter units will have (3), longer units may have (6). **See Figure 1.**

NOTE: if the unit was ordered with a decorative rear cover, the air curtain will arrive with the cover already installed, and the wall mounting plates will not be included in the shipment. Contact Berner, if they are required, for no charge.

Immediately verify that the electrical rating nameplate located on the cover matches the electrical power supply available. Retain the shipping carton(s) until the air curtain(s) are installed and properly operating.

ACCESSORIES: If the air curtain(s) were ordered with optional electrical accessories, the accessories will be found in the carton containing the air curtain packed in a red bag (marked "additional parts inside") or in a separate carton(s) accompanying the air curtain(s).

Check all of the cartons/skids for accessories before discarding.

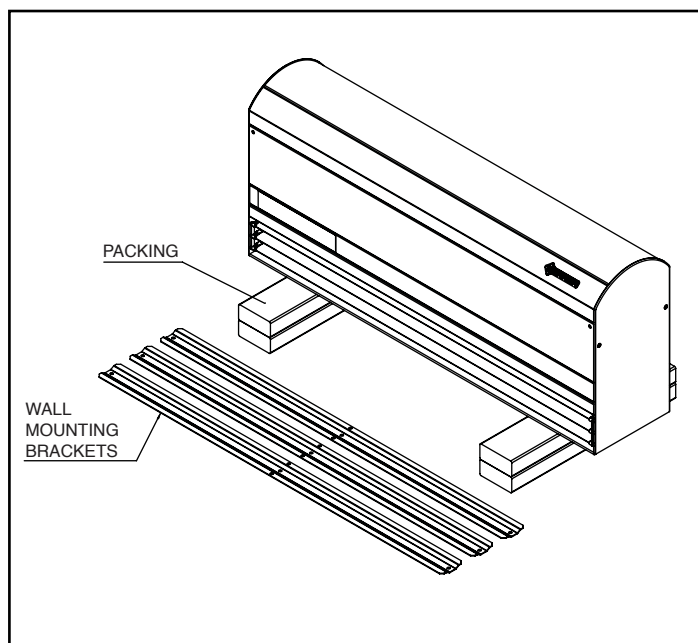
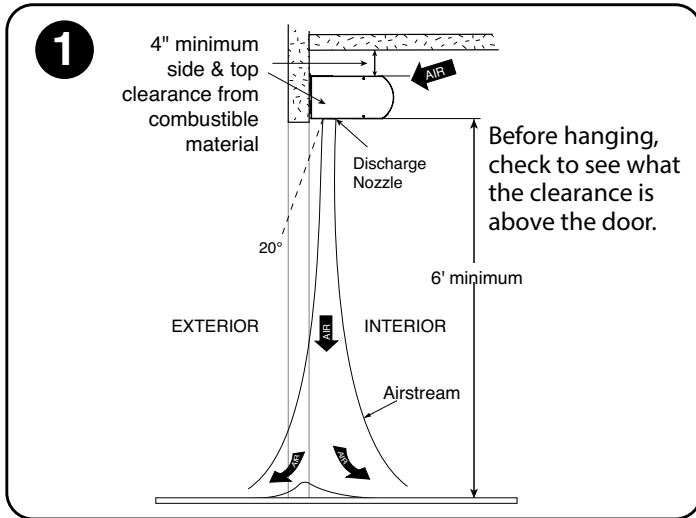
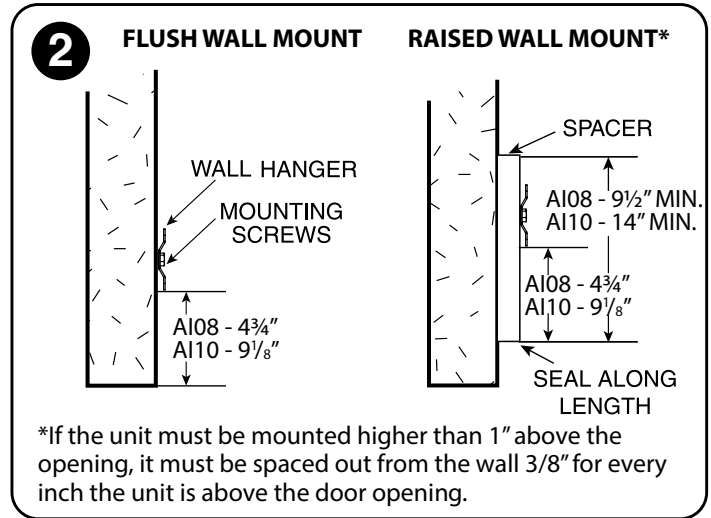

Figure 1 - Uncrating



For more information see page 4



For more information see page 4

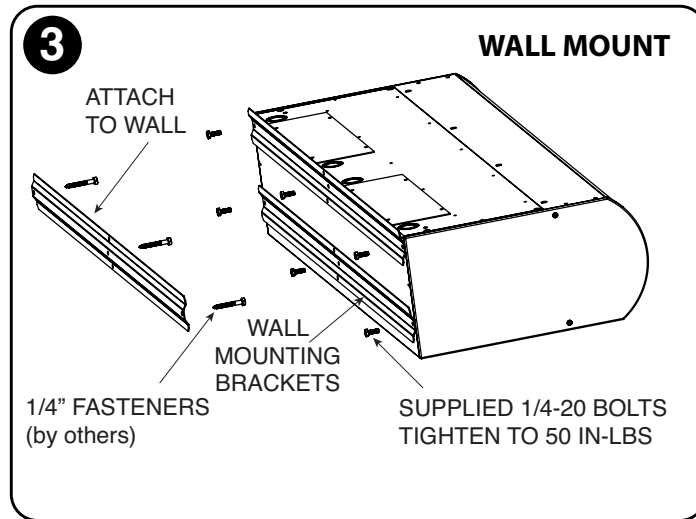

For more information see page 5

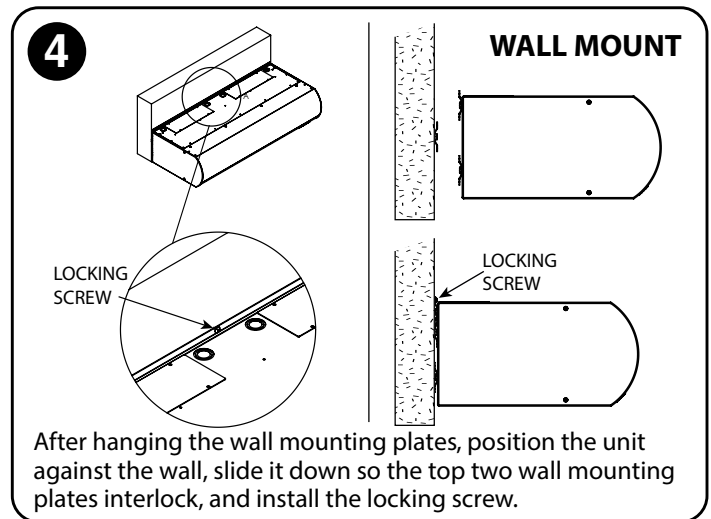

For more information see page 5

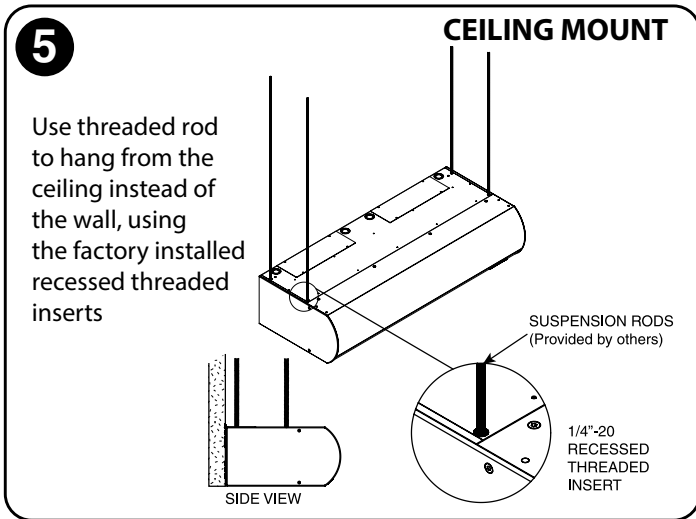

For more information see page 5

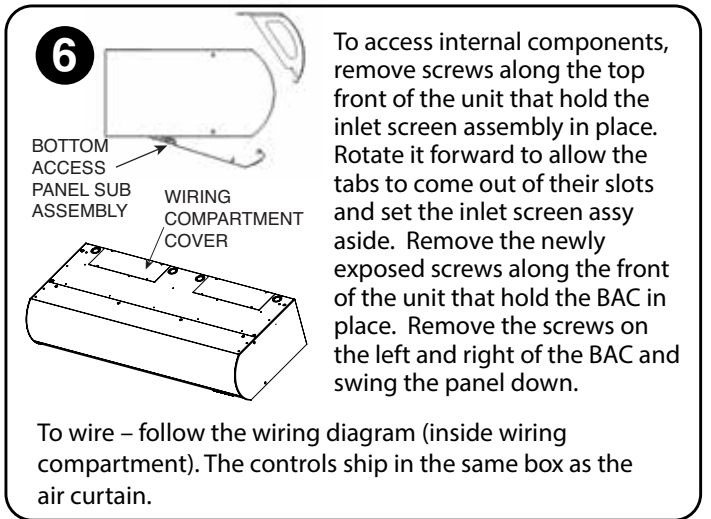

For more information see page 8

II. MOUNTING INSTRUCTIONS (General)

INDOOR MOUNTING ONLY -

To achieve optimum protection, the air curtain should be mounted on the inside of the building, flush to the wall and as close to the top of the door opening as possible. To ensure peak performance, keep the air stream free of obstructions.

The air curtain will not perform properly if negative air pressure exists in the building. Under these conditions, a means for makeup air to the building must be provided so that the air pressure on both sides of the opening is in balance.

Before mounting the air curtain, check the supporting structure to verify that it has sufficient load-carrying capacity to support the weight of the air curtain(s). The mounting hardware (supplied by others) should be capable of supporting a minimum of three (3) times the weight of the air curtain.

See Table 1.

IMPORTANT: A minimum of 4" is required above the top rear corner of the air curtain for the installation and removal of the inlet screen, and to ensure proper airflow.

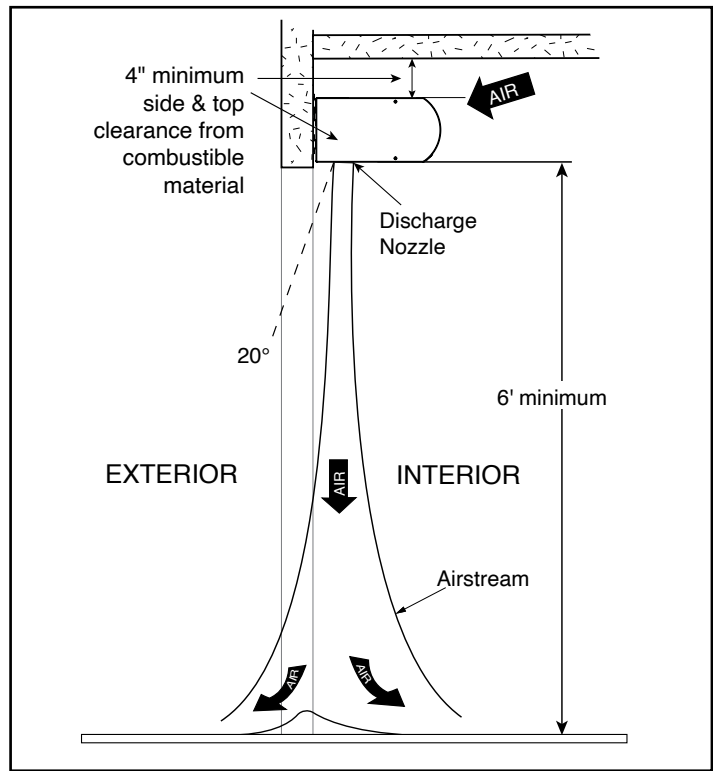

Figure 2 - General Mounting

- A. When determining the mounting location for the air curtain(s), make sure that nothing interferes with the curtain of air developed when the discharge vanes are directed from 0° to 20° toward the door opening. If the air stream strikes any obstruction (the top edge of the doorway, a door opening device, etc.), the effectiveness of the air curtain will be greatly reduced. **See Figure 2.**
- B. For optimum performance, the bottom of the air curtain (discharge nozzle) should be no more than 1" above the top of the door opening with the air curtain(s) mounted flush to the wall. If the air curtain must be mounted higher, it must be spaced out from the wall 3/8" for every inch the air curtain is above the door opening. **See Figure 3.** For optimum protection, any void between the air curtain and the wall should be sealed along the full length of the air curtain.
- C. Do not block (obstruct) the air intake screen. Insufficient airflow can cause the unit to overheat.
- D. **The air curtain(s) shall:**
 1. Have a minimum clearance of at least 4" from the sides and 4" from the top.
 2. Have a minimum clearance of at least 6' between the bottom of the air curtain and the floor.
 3. Be installed Indoors Only.
- E. Proceed to either **Section III - WALL MOUNTING** or **Section IV - SUSPENDED MOUNTING**

MODEL	Net Weight				MODEL	Net Weight			
	AI10 Amb.	AI10 Elec.	AI10 Steam	AI10 Hot Water		AI08 Amb.	AI08 Elec.	AI08 Steam	AI08 Hot Water
AI10-E-1036	85	88	110	107	AI08-E-1036	48	53	68	68
AI10-E-1042	94	97	122	119	AI08-E-1042	53	58	76	75
AI10-E-1048	110	113	141	138	AI08-E-1048	58	63	83	83
AI10-E-1060	119	122	156	153	AI08-E-1060	69	74	99	99
AI10-E-2072	170	176	216	210	AI08-E-1072	79	89	117	117
AI10-E-2084	188	194	240	234	AI08-E-2084	106	116	149	149
AI10-E-2096	220	226	278	272	AI08-E-2096	116	126	164	164
AI10-E-2108	229	235	293	287	AI08-E-2108	127	137	180	180
AI10-E-2120	238	244	306	300	AI08-E-2120	138	148	196	196
AI10-E-3132	305	314	384	375					
AI10-E-3144	330	339	415	406					

TABLE 1 - Weight Chart

III. WALL MOUNTING

A. PREPARATION

1. Locate the wall mounting plates, in the carton that contained the unit. **See Figure 4.** For units over 72", there are more than two wall mounting plates.
2. Use 1/4"-20 bolts to attach the wall mounting plates to the back of the air curtain.

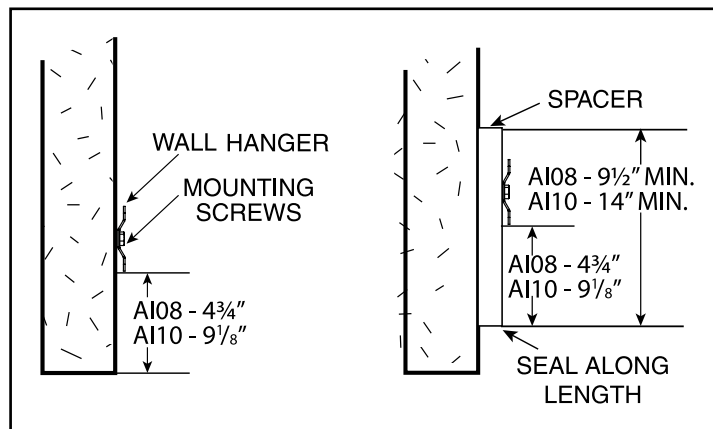

Figure 3 - Wall Mounting Location

NOTE: The three wall mounting plates are identical. Two of the wall mounting plates are attached to the back of the air curtain, and one is attached to the wall.

3. The mounting hardware (supplied by others) must be capable of supporting a minimum of three times the net weight of the Air Curtain. **See Table 1.**

B. MOUNTING WALL PLATES

1. Position wall mounting plate over the door opening as shown in **Figure 3**. The plate should be centered over the door opening.
2. Using minimum 1/4" fasteners (supplied by others), secure the wall mounting plate to the supporting structure. **NOTE:** It is acceptable to drill holes through the plate mounted to the wall to allow fasteners to hit a wall stud. Fasteners must be placed within 6" of the ends of the air curtain cabinet.

C. ATTACHING THE AIR CURTAIN TO THE WALL MOUNTING PLATES

1. Raise the unit over the door (air discharge nozzle facing down) and onto the wall mounting plates. **See Figure 5.**
2. Position the unit against the wall, slide it down so the top wall mounting plate (attached to the unit) interlocks with the wall mounting plate that is attached to the wall. Add one locking screw in the top middle of the wall mounting plate. **See Figure 5.**
3. Proceed to **Section V - ELECTRICAL CONNECTIONS**

IV. SUSPENDED MOUNTING

NOTE: if the unit was ordered with a decorative rear cover, the air curtain will arrive with the cover already installed, and the wall mounting plates will not be included in the shipment. Contact Berner if they are required.

- A. For top mounting using suspension rods, four (4) factory installed 1/4"-20 threaded inserts are located on the top of the unit. **See Figure 6.**
- B. Install 1/4"-20 threaded rods, or other suitable hardware at a location sufficient to support the Air Curtain. The mounting hardware (supplied by others) must be capable of supporting a minimum of three times the net weight of the Air Curtain. **See Table 1.**
- C. Attach 1/4"-20 threaded rods, or other suitable hardware to the top mounted threaded inserts. Secure threaded rods with locking nuts.
- D. Proceed to **Section V – ELECTRICAL CONNECTIONS**

V. ELECTRICAL CONNECTIONS

All electrical wiring and connections **MUST** be performed by qualified personnel in accordance with the latest edition of the National Electrical Code ANSI/NFPA No. 70 or, in Canada, the Canadian Electrical Code, Part 1-C.S.A. Standard C22.1 and local codes and regulations.

MAKE SURE THE CORRECT VOLTAGE AS MARKED ON THE UNIT IS USED.

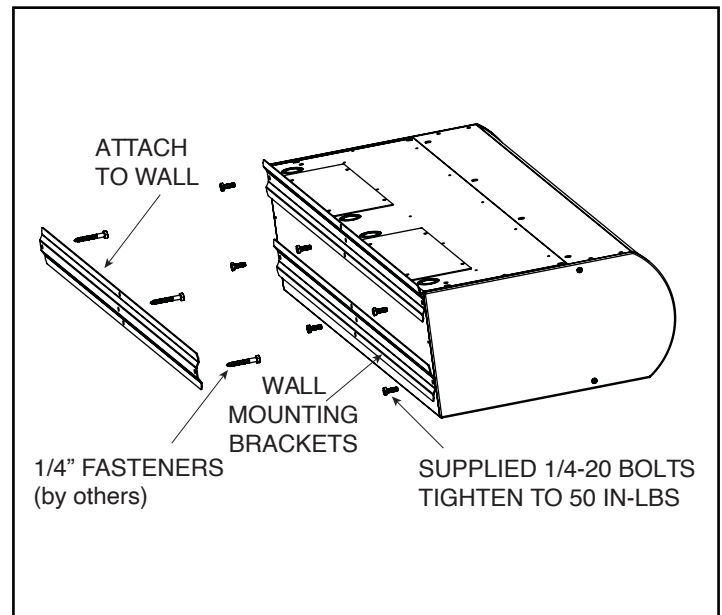

Figure 4 - Wall Mounting Preparation

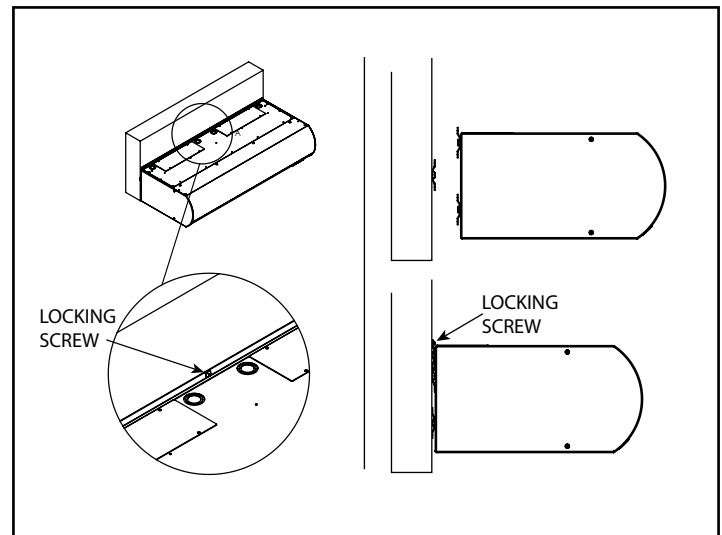

Figure 5 - Wall Mounting Installation

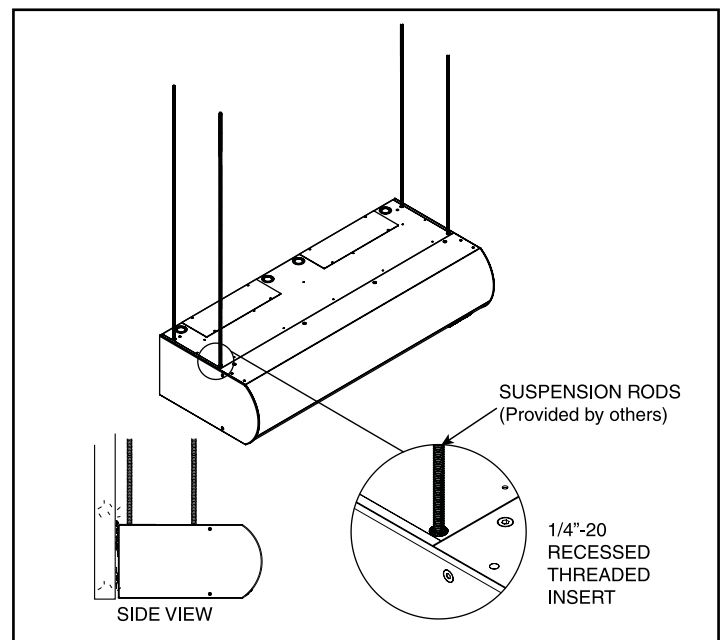

Figure 6 - Suspended Mounting

- A. A separate line voltage supply with a suitable branch circuit protection device should be run directly from the main electrical panel to the unit. A disconnect switch for each branch circuit is a required part of this installation. See the voltage label on the unit for circuiting and total electrical load. The wiring diagram is located in the wiring compartment, located on the top of the unit.

See Figure 7.

- B. All field wiring must be copper with a minimum insulation of 60°C within approved conduit. If any of the wire supplied in the unit must be replaced, it must be replaced with copper wire with a minimum insulation of 90°C.
- C. Electric and hot water heated air curtains are factory equipped with an unit mounted solid state temperature sensor located internally to measure the incoming (return) air stream.
- D. Remove the wiring compartment cover.
- E. Connect all supply and control circuit wires according to the wiring diagram provided.

NOTE: For Electric and Hot Water heated air curtains provided with an optional remote thermostat, mount and wire the thermostat according to thermostat instructions and wiring diagram.

For BACnet-IP Integration –

see **XI - Appendix C, "BACnet-IP integration."**

For Serial Network Connection - proceed to

XI - Appendix A, "Serial/Network Connection."

NOTE: The air curtain must have been ordered from the factory with this option.

For Wall Mounted Touchscreen – proceed to

XI - Appendix B, "Wall Mounted Touchscreen."

if optional remote Touchscreen control of the Intelliswitch™ has been ordered from the factory.

For Electric and Hot Water air curtains - proceed to **Section VI - Field Connections**, otherwise proceed to **Section VII - Operating Instructions**

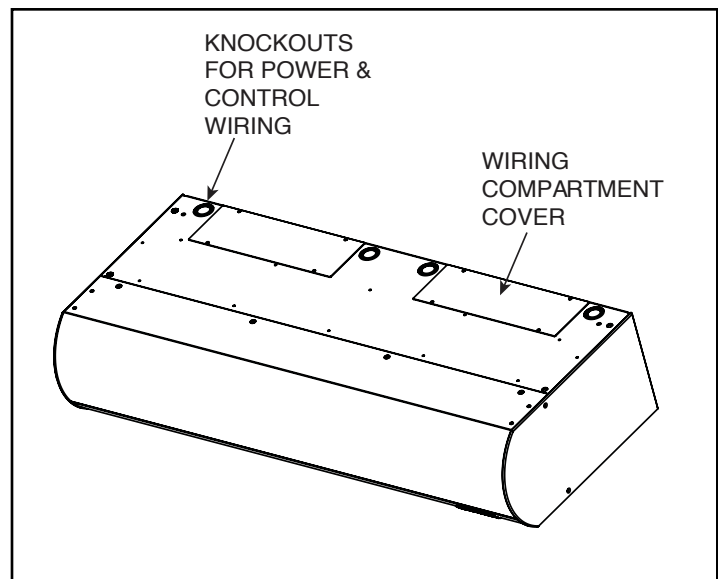

Figure 7 - Electrical Connections

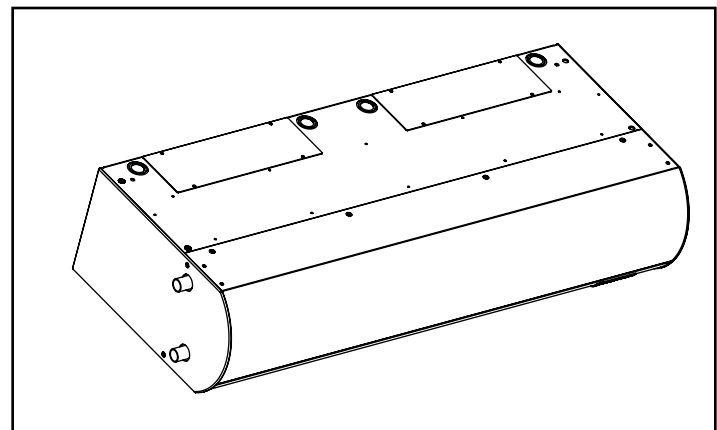

Figure 8 - Steam / Hot Water Connections

VI. FIELD CONNECTIONS

A. ELECTRICALLY HEATED MODELS

The heater circuit may be controlled by an optional remote thermostat or through the built-in Intelliswitch™ thermostat, which on Model IC08 is located in the wiring compartment, and on Model IC10 is factory installed inside the air curtain. Overheating protection is provided by auto reset thermal cutouts built into the heater coil assembly (see the wiring diagram located in the wiring compartment). **See Figure 7.**

B. STEAM OR HOT WATER HEATED MODELS

An optional water coil solenoid valve (by others or Berner) may be controlled through the Intelliswitch™ or independently. The Intelliswitch™ is capable of providing the same voltage used for the motor to power a solenoid load up to 5 amps. This call for heat may be controlled by an optional remote thermostat or through the built-in Intelliswitch™ thermostat located on top of the air curtain. Piping should be done in accordance with local codes, regulations and standard practices. Connect the building system to the (3/4"-AI08 or 1"- AI10) MPT supply and return header connections. **See Figure 8.**

VII. OPERATING INSTRUCTIONS

This air curtain comes with the **Berner Intelliswitch™ Digital Controller** built-in to control and schedule fan activation, fan speed selection, and heat activation. If the optional Berner AIR™ system (smart controller and app) was ordered, it includes additional features such as BACnet capability and adaptive settings. The air curtain must be properly installed before either of these can be used.

A. GENERAL OPERATION

1. To operate using the built-in Intelliswitch digital controller, proceed to the **Quick Start Operation Guide, page 10**.
NOTE: For a detailed Intelliswitch Programming Guide, go to www.Berner.com/Intelliswitch
2. Unheated units will have the fans activated by a door switch or sensor. The unit speed can be selected via the Intelliswitch™ display or the Berner AIR App*
3. Heated units will have fans activated by a door switch or sensor, but may also be activated by the thermostat in Comfort Plus Mode. The unit's speed can be selected via the Intelliswitch display or the Berner AIR App.*
4. To operate using the Berner AIR™ App*, download the app and follow the prompts. Requires on-site, secure wi-fi connection. Berner recommends having the on-site user(s) set-up the Berner AIR™ App on his/her smart phone.
5. To operate using BACnet-IP client, download the Berner AIR™ App*. In the settings menu of the app, select the BACnet option. Follow the prompts to configure the BACnet controller. To connect via wire, *see Appendix C. BACnet-IP Integration*.

*NOTE: The air curtain must have been ordered from the factory with the Berner AIR (smart controller & App) option.

B. AIR STREAM ADJUSTMENT

1. With the air curtain operating and the door in its full open position, check to see that nothing is obstructing the airflow at the discharge nozzle vanes.
2. Find the air stream split location. Hold a handkerchief by its corners, approximately 12" above the floor. Gently move the handkerchief back and forth in the doorway. Make sure the air is being directed to both the inside and the outside. *See Figure 9*. The split location is indicated where the handkerchief is vertical with minimal or no fluttering.
3. The split location should be approximately 3" outside the doorway. If necessary adjust the discharge nozzle vanes by de-energizing the unit and firmly pushing/pulling on the vane tip until properly located.

If ordered with the Berner AIR™

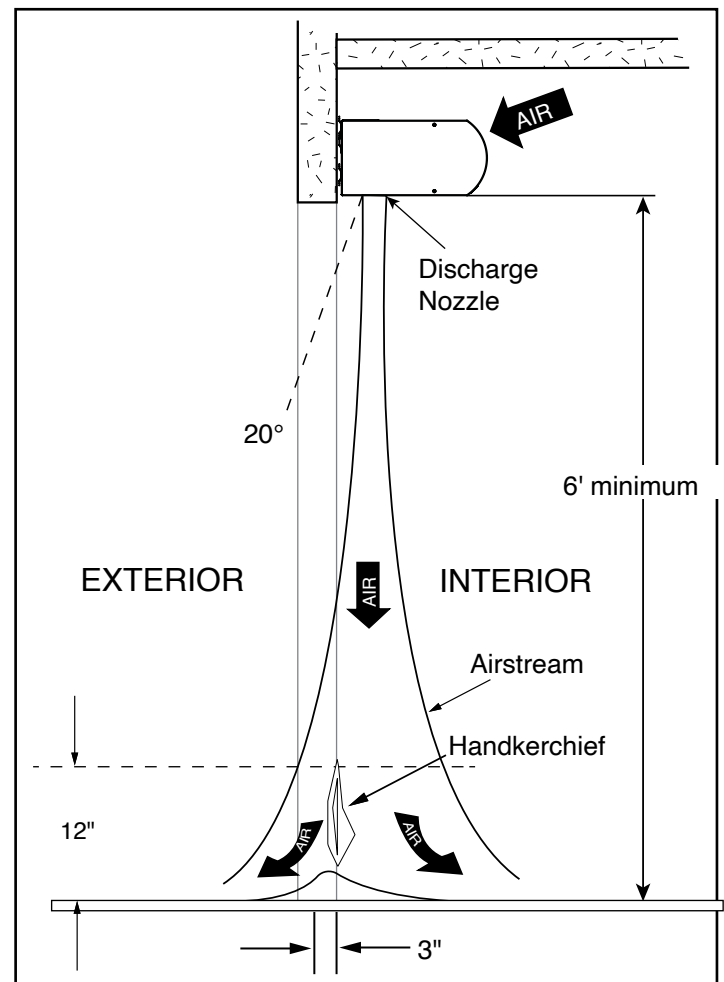
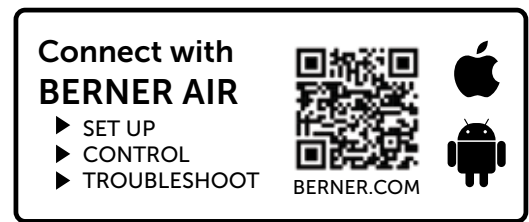

Figure 9 - Air Stream Adjustment

VIII. MAINTENANCE & CLEANING

CAUTION: ELECTRIC SHOCK HAZARD Disconnect power whenever servicing unit. More than one disconnect may be required to de-energize unit.

Stainless steel appliance wipes are recommended for wiping down both the bottom panel and the cabinet.

Keep your air curtain operating at peak efficiency by cleaning the blower wheels, motor(s) and intake screen. Buildup of dust on the blower wheels can cause vibration, noise and excessive wear on the motor bearings. The frequency of cleaning will

Dirty, dusty or greasy environments could require a cleaning schedule of once every month. If the environment is not that dirty, the unit(s) should be scheduled for cleaning a minimum of once every six months. The air inlet filter typically requires cleaning every three to six months.

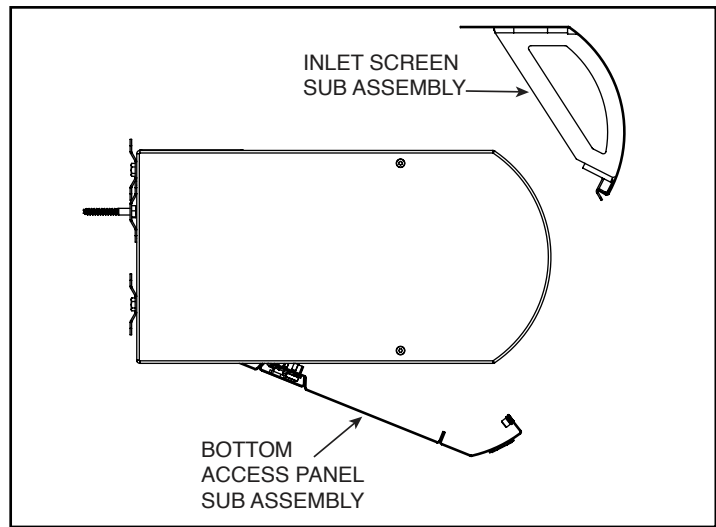

Figure 10 - Bottom Access Cover (BAC) Removal

A. PERFORMING PREVENTIVE MAINTENANCE

1. **Disconnect the power to the unit.**
2. **Filter** - the aluminum washable filter is held in by the intake screen. Access the filter by removing the Phillips head flush mount screws across the top front of the unit. Rotate the inlet screen forward slightly to allow its tabs to be removed from the bottom front cover. Vacuum and/or wash with dish soap and water.
3. **Internal** - open the bottom access panel by removing the inlet screen as described above, and then removing the now exposed fasteners across the front of the BAC, and the two screws along the bottom left and right side. The BAC is hinged, so carefully allow it to swing down. Vacuum and scrape (if necessary) to remove the build-up of dirt and debris. The motor(s) are permanently lubricated and require no additional lubrication.
4. Re-install the cover and intake screen. **See Figure 10.**
5. Switch the power on after cleaning.

CAUTION: STAND CLEAR OF THE UNIT OR WEAR SAFETY GOGGLES AS LOOSE DEBRIS MAY BE PRESENT AND MAY EXIT THE NOZZLE UPON START UP!

IX. SERVICE

CAUTION: ELECTRIC SHOCK HAZARD Disconnect power whenever servicing unit. More than one disconnect may be required to de-energize unit.

Any service performed on the ARCHITECTURAL Icon Series air curtain **MUST** be done by qualified personnel. Berner air curtains require very little servicing. All parts are easily accessible for periodic inspection and maintenance. Units should be cleaned at least twice a year. Your particular application (the amount of dirt and dust in the air) and location of the unit(s) will determine how often your unit(s) will need to be cleaned and serviced. All motors have permanently lubricated, sealed, sleeve bearings and require no maintenance.

A. REPLACING FANS AND/OR MOTORS

CAUTION: ELECTRIC SHOCK HAZARD Disconnect power whenever servicing unit. More than one disconnect may be required to de-energize unit.

AI08: To replace fans and/or motors. See Figure 11

1. Lock out power from the unit.
2. Swing down the bottom access cover (BAC) by removing the flush screws across the front bottom of the unit
3. Disconnect the motor wiring harness.
4. Using a 1/8" hex driver, loosen the set screws (one on each fan) that secure the fan hubs to the motor shafts.
5. Loosen, but do not remove the screw on each fan bearing retainer and rotate up to fully expose the fan bearing.
6. Slide each fan in towards the motor as far as possible.
7. While supporting the motor with one hand, remove the screws at the top of the motor mount. This will free the motor/fan assembly.
8. Lower the motor/fan assembly out of the unit. Ensure the rubber bearing cushions come out with the fan bearings.
9. Replace in reverse order. Note that when reinserting the fan bearings, ensure the rubber bearing cushion is properly seated. Improper seating can result in fan failure.

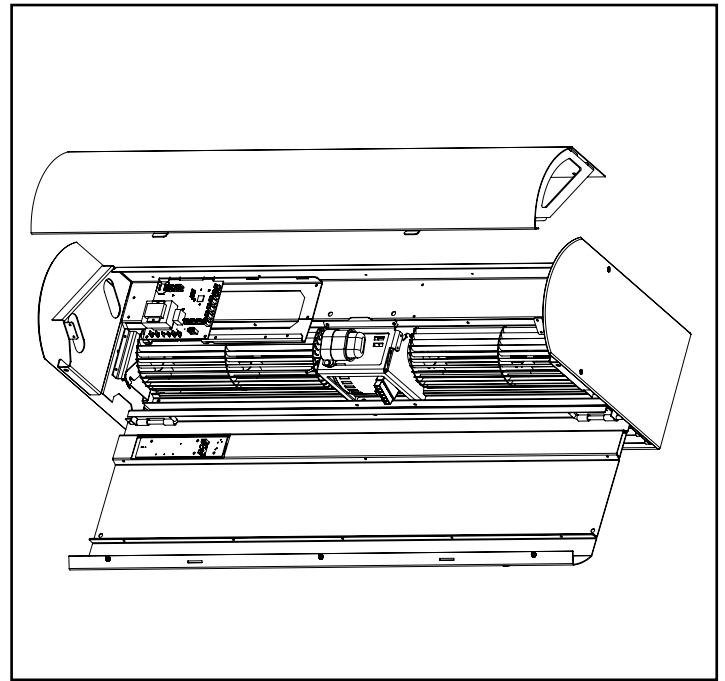

Figure 11 - Architectural Icon 08 (AI08) – Replacing Fans /Motors

AI10: To replace fans and/or motors. See Figure 12

1. Lock out power from the unit.
2. Swing down the bottom access cover (BAC) by removing the flush screws across the front bottom of the unit.
3. Disconnect the motor wiring harness.
4. If the module has electric heaters, mark the electrical connections and disconnect them. Remove the heaters by unscrewing their mounting brackets from the fan housings. When reinstalling the heaters, take care to not over torque these fasteners.
5. Support the blower module by holding the motor. Removing the (2) #12 hex head screws that secure the blower module to the top channel with a 5/16" socket. This operation may be easier with two people; one to support the blower module and one to remove the screws.
6. Lower the blower module onto a workbench.
7. Using a 5/32" hex driver, loosen the set screws (one on each fan) that secure the fan hubs to the motor shafts.
8. Remove the screws on the back of the blower plate that secure the fan housings to the blower plate.
9. Slide the fan impellers and housings off of the motor shaft.
10. Detach the motor ground wire from the motor mount.
11. Remove the clips that hold the motor to the motor mount.
12. Replace in reverse order.

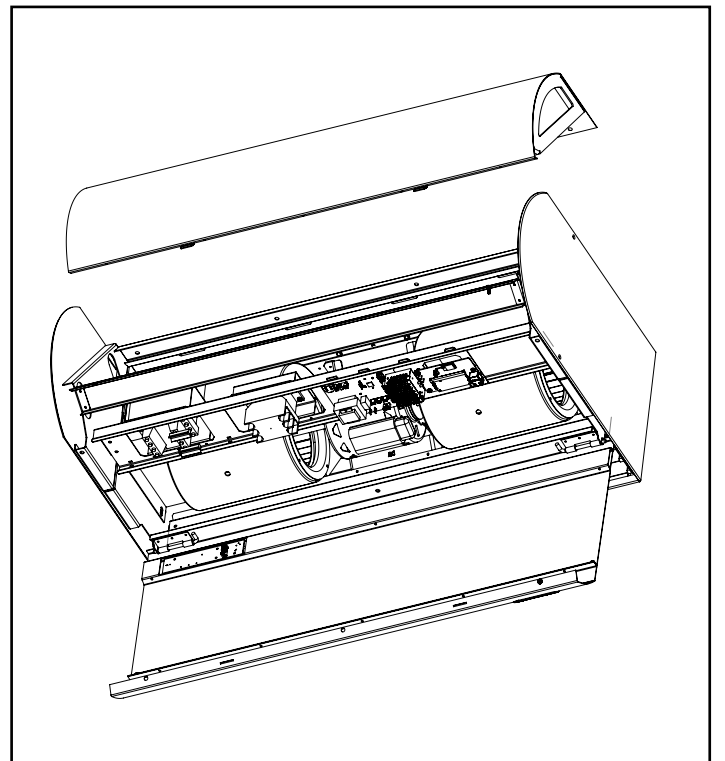

Figure 12 - Architectural Icon 10 (AI10) – Replacing Fans /Motors

QUICK START INSTRUCTIONS

For your *Berner Air Curtain with Intelliswitch™ Gen4*

www.Berner.com/intelliswitch



NOTE – to navigate, use ▲ ▼ to select setting
use + – to change setting,
then press ✓ to enter the setting.

Stop: Immediately stops the air curtain and changes mode to **OFF**

"i": info button provides controller status and diagnostic data

Mode/Fan Speed:

Mode: Select your mode of operation (see next page)

Fan Speed: Sets the fan speed

Delay Time: Sets the amount of time the air curtain runs after the door closes

Temp Set: Sets the temperature the air curtain will maintain (heated units only)

Start Time: Programs the time of day the air curtain becomes active

Stop Time: Programs the time of day the air curtain stops running

Set Time/Day: Sets the clock time and day (used by programming)

Locked: Unit will run as programmed but settings cannot be changed

NOTE: Start/Stop time must be the same for the air curtain to operate continuously.

IMPORTANT NOTE!

If your air curtain unit is in "Locked" mode when you receive it:

Press and hold the + for 5 seconds to unlock.

STEP ONE





To Start: Press the down arrow button once.

NOTE: To change from "Mode" to "Fan Speed" press the down arrow twice.

STEP TWO



Use the   buttons to scroll through the available modes of operations.



Standard Mode of Operation Options:

OFF

Door opens: The air curtain is off.

Door shuts: The air curtain is off.

ON

Door opens: The air curtain activates immediately when mode is selected.

Door shuts: The air curtain continues to run.

AUTO

Door opens: The air curtain activates.

Door shuts: The air curtain turns off, after time delay expires.

PLUS

Door opens: The air curtain and heater (if temperature is below thermostat setting) activate and run at set speed.

Door shuts: The air curtain turns off after the time delay expires. If thermostat is not satisfied, air curtain and heater continue to run until the thermostat is satisfied. If the thermostat drops below set temperature, the heater and air curtain will activate and run on a low speed until the thermostat is satisfied.

For heated units only

Customizable Mode of Operation Options:

See www.berner.com/intelliswitch for programming directions

(Section 5, Program Menu).

STEP THREE



Once the **Mode of Operation** is selected, press the  button.

INTELLISWITCH™ Gen4 FAQ's (Frequently Asked Questions)

www.Berner.com/intelliswitch

WARNING: TO REDUCE THE RISK OF FIRE, ELECTRIC SHOCK OR INJURY TO PERSONS, OBSERVE THE FOLLOWING: Before servicing or cleaning unit, switch power off at service panel and lock the service disconnecting means to prevent power from being switched on accidentally. When the service disconnecting means cannot be locked, securely fasten a prominent warning device, such as a tag, to the service panel.

Even though every Architectural Icon is individually tested at the factory before shipment, on occasion improper functionality may be experienced. Here is a list of common questions

Q. Why can't I change my settings?

A. The Intelliswitch™ may be locked. If the Lock light is illuminated, the control is locked. To unlock, press and hold the "+" button for 5 seconds. The Lock mode can also be protected with a PASScode. If the PASScode option is on, an attempt to unlock the control will display PASS and then a 0000 prompt. The four digit code "2376" must then be entered to unlock the control. Use the "+" and "-" to select a number and the up and down arrows to select the digit to edit. Press OK when done. Note: If the AutoLock setting is on, the control will re-lock if there is no activity after 5 minutes.

Q. Why won't my heat work, even though fans are running?

- A.** The thermostat(s) may need adjusted or replaced.
1. Make sure that the thermostat probe and/or remote thermostat are in the "On" position and set above ambient (room) temperature.
 2. Check internal and external thermostat status in the Diagnostics Menu for a faulty thermostat. To do this, press the "i" button and "diag" will appear, then arrow down to the "ts" setting, if it displays "1" then the thermostat(s) is working (there is a call for heat).
 3. If no external thermostat is used, check to see if the internal thermostat probe is connected. Disconnect power to the unit, remove the bottom cover and check that the beige sheathed cable is attached to the pins on the control board marked "temp sensor". Check to see that the removable probe tip is connected to the other end of this cable. If the internal thermostat is connected and the thermostat settings are correct and you are still not getting heat, check to see if the fan speed range is correct.
 4. Check the fan speed range in the Factory Menu. First find the unit's two digit speed range on the wiring diagram shipped in the wiring compartment and attached to the inside of the bottom cover. Navigate to the factory menu to check the range. Press the info "i" button to display "diag". From here press and hold the "+" button for 5 seconds and "Fact" will display. Use the down arrow to navigate to the "rn" setting and compare the two digit number displayed. If it matches, press the "√" to exit. If it does not match, use the "+" or "-" to change the number to match exactly. Press "√" to exit.
WARNING: setting the wrong speed range can severely damage the unit and lead to personal injury or a safety hazard.
 5. If there is still no heat, you may need a new heater relay, control board or thermal cutout: consult factory.

Q. Why won't the Intelliswitch™ light up?

- A.** There may not be power to the control.
1. Check to see if the main power is turned on to the unit. Your air curtain may have multiple disconnects, be sure all are turned on.
 2. **NOTE: ONLY QUALIFIED PERSONS SHALL CHECK POWER IN THE UNIT WITH THE POWER ON.** Verify that there is power to the control board. The power terminals are on the control board which is located inside the unit. Remove the bottom cover the access the internals and expose the power terminals. Check the line voltage at spade terminals L2 and 120, 208 or 240 (depending on the voltage supplied to the unit).
 3. Check the ribbon cable connections to the display board for a loose connector or improperly connected cable (see Installation Instructions for correct cable connection).
 4. If display still doesn't light, unplug the door switch/ remote thermostat harness and thermostat probe (if a heated unit) from the control board. If the display lights, plug one component back in at a time to see which one may be shorted. The faulty component will make the display go blank again.
 5. If there is line voltage power at the board terminals, the ribbon cable is correctly connected and the thermostat are working, and it is still not working, you may need a new control board: consult factory.

Q. Why won't my fans shut off?

- A.** The Intelliswitch™ may be in the wrong mode or mis-wired.
1. Check to see if the control is in the "ON" mode, if it is, then change the Mode to another setting.
 2. If there is a door switch and the unit is in a mode that is activated by it, there could be a short, mis-wiring or mix-up in components. Close the door and check the door switch status in the Diagnostics menu. Press the info "i" button and "diag" appears, then arrow down to the "ds" setting, if it displays "1" then the door switch signal is closed (there is a call for fan). If the door is closed, the signal should be "0" or open.
 3. There could be a short in the field connections to the door switch or the door switch leads could be mis-wired. To test, disconnect the door switch connection at the unit. Open the wiring compartment on top of the unit and be cautious of high voltage connections. Disconnect the blue wires labeled 9 & 10 from the field wiring to the door switch or make sure they are not tied together. There is no danger of getting shocked because the signal is 5 volt DC. Be sure not to touch the blue wires to anything metal (or grounded). The unit should shut off when it is in any mode that is activated by the door switch.

Continued on next page ...

INTELLISWITCH™ FAQ's Continued (Frequently Asked Questions)

www.Berner.com/intelliswitch

4. If the air curtain is heated, make sure that the thermostat isn't wired to the door switch leads. Door switch leads are blue and labeled 9 & 10.

Q. How can I check the door switch to be sure it's working?

A. The Intelliswitch™ may be in the wrong mode, be mis-wired or have a faulty door switch.

1. First test the wiring and controller function at the same time. Locate the door switch and open its wiring compartment. There should be two wires connected to screws inside the switch. There is no danger of getting shocked because the signal is 5 volt DC. Be sure not to touch the wires to anything metal (or grounded). With air curtain in "Auto" mode, either disconnect both wires from the screws (marking which screws the wires are under) and touch them together or make a short jumper wire and touch the jumper to both screws at the same time to see if air curtain comes on. If it does, the controller and wiring work.
2. If the wiring and unit pass the function test, the problem could be either misalignment or a faulty door switch. On a magnetic reed switch check for magnet alignment, for plunger/roller type switch, check contact engagement with door.
3. If you have access to an electrical test meter, the door switch contacts can be tested for continuity when the door switch wires are disconnected from the unit.

Q. Why won't my heat shut off?

A. The Intelliswitch may need adjusted, have been mis-wired or have a faulty thermostat.

1. Heat is activated by one of two thermostat connections. To test the internal thermostat set the external thermostat to OFF. The settings of the unit mounted thermostat probe are accessed through the display. Press the down arrow until the Temp Set indicator lights up; check if the temperature setting and unit of measure are correct. Test to see if it shuts off by setting the thermostat temperature to OFF or lower than the room temperature.
2. If an external thermostat is connected to the unit, there could be a short in the field connections or the thermostat leads may be mis-wired. To test the external thermostat set the internal thermostat to OFF. Disconnect the external thermostat connections at the unit. Open the wiring compartment on top of the unit and be cautious of high voltage connections. Disconnect the orange wires labeled 6 & 7 from the field wiring or make sure they are not tied together. There is no danger of getting shocked because the signal is 5 volt DC. Be sure not to touch the orange wires to anything metal (or grounded). The heat should shut off when the wires are separated. For more complex troubleshooting of either thermal cutouts or heater relays, please consult a qualified electrician or consult the factory.

Q. Why didn't the Intelliswitch™ save the changes I made to a program?

A. If a program is active (a dot is illuminated under one of the clock digits), changes can be made to any settings on the User Menu. These changes however will only remain in effect until the program changes to the next time zone. To make changes permanent, settings must be changed in the program from the Program Menu. Access the Program Menu by holding down the "-" button for 5 seconds until "Pro" is displayed. Arrow down to select the program to edit and press "√" to select the program editor. Use the down arrow to step through the options and make changes as desired using the "+" and "-". Continue to press the down arrow until "Stor" is displayed. Press "√" to keep or store the changes.

Q. How do I undo a change that I made to a program in the Program Menu?

A. Changes to programs cannot be undone.

1. Changes can be changed back by going to the programming menu and re-editing the program back to what it was or resetting all programs back to factory default.
2. Resetting the programs to the factory default must be done on the Factory Menu. Access to the Factory Menu is from the Diagnostics Menu. Press the info "i" button and "diag" is displayed. From the "diag" display press and hold the "+" for 5 seconds until "Fact" is displayed. Use the down arrow to select "DEFn" on the display then use the "+" to select "DEFP". Press "√" to reset. The control display will go blank then blink as confirmation.

Q. My air curtain won't turn on?

A. The Start and Stop time must be set to the exact same time for the unit to be active full time. Check the AM/PM setting on the Start and Stop times or the clock (considering the PM indicator light when setting values). If a program is being used, check to see if a program is active that may have different start/stop times than those expected.

Q. My building has a Building Management System, can the Intelliswitch work with a BMS?

A. The Intelliswitch can be controlled by a Building Management System (BMS) but currently does not have the ability to communicate directly with them. Dry contacts on the BMS may be used to control the unit activation through the door switch connections (blue wires 9 & 10) and the heat activation through the remote thermostat connections (orange wires 6 & 7). Consult factory.

X. TROUBLESHOOTING

SYMPTOMS	CAUSE	REMEDY	
NO AIR	<ul style="list-style-type: none"> Power supply line open (no power) Fuse blown/circuit breaker tripped Motor overload tripped Failed switch 	<ul style="list-style-type: none"> Check power source, check service disconnect, check method of control in ON position Replace fuse(s)/reset breaker Internally protected motor - should reset automatically after cool-down, if not, replace motor. Replace switch 	
	MOTOR RUNNING/FANS ARE NOT ROTATING		
	<ul style="list-style-type: none"> Broken or damaged flexible hub Shaft rotating inside fan 	<ul style="list-style-type: none"> Replace fan sleeve/reengage coupling Tighten set screws/tighten fan on shaft 	
ELECTRICAL CONTROLS NOT FUNCTIONING WHEN DOOR IS OPEN			
MINIMUM AIR	<ul style="list-style-type: none"> Air directional discharge vanes mis-adjusted Inadequate intake clearance Blower motor operates below speed Fan rubbing against housing Fan wheels clogged with dirt Fan in backwards 	<ul style="list-style-type: none"> Adjust vanes to proper position, see instructions Move air curtain or remove obstruction Provide adequate space for air curtain Improper voltage Free fan from housing Clean and vacuum fan wheels Check fans for blade curve toward discharge 	
	AIR IS NOT HITTING FLOOR	<ul style="list-style-type: none"> Air stream too weak Air stream hits obstruction Negative pressure 	<ul style="list-style-type: none"> Adjust nozzle to proper position, adjust motor speed; see installation instructions Remove obstruction or reposition air curtain (move out 3/8" for every 1" up from the door) Relieve negative pressure by providing makeup air
		<ul style="list-style-type: none"> Shaft rotating inside fan One motor not operating 	<ul style="list-style-type: none"> Tighten set screws Repair or replace motor
EXCESSIVE AIR MOVEMENT AT DOORWAY	<ul style="list-style-type: none"> Nozzle not angled out far enough Unit too powerful Air movement too cold Pushing air outside building <p>SEE AIR IS NOT HITTING FLOOR SYMPTOMS</p>	<ul style="list-style-type: none"> Adjust nozzle angle to outside Adjust motor speed Add auxiliary heat to overcome wind chill factor Adjust discharge angle back into building, adjust motor speed 	

ELECTRICALLY HEATED MODELS

NO HEAT	<ul style="list-style-type: none"> Switch turned to "ON" position Thermostat not set properly Coils burned out due to lack of air Automatic reset thermal cutout failed in open position Manual reset thermal cutout tripped (if supplied) 	<ul style="list-style-type: none"> Replace switch or check wiring Change thermostat setting Correct airflow problem; replace coils Replace automatic thermal cutout Reset manual thermal cutout
MINIMAL HEAT	<ul style="list-style-type: none"> Thermostat in wrong location - thermostat too close to discharge Improper voltage Thermostat not set properly Low entering air temperature 	<ul style="list-style-type: none"> Move thermostat away from air stream Supply proper voltage Change temperature setting Based on unit temperature rise, reduce speed
EXCESSIVE HEAT	<ul style="list-style-type: none"> Incorrect speed range Thermostat in wrong location Thermostat not set properly Insufficient air over coil Improper voltage 	<ul style="list-style-type: none"> Check Factory Menu speed range matches diagram Move the thermostat closer to air stream Change temperature setting Remove restriction on intake Supply proper voltage

STEAM / HOT WATER HEATED UNITS

EXCESSIVE HEAT	<ul style="list-style-type: none"> Too high steam/hot water pressure Inadequate air flow, fins plugged up, dirty coils 	<ul style="list-style-type: none"> Reduce steam pressure / hot water flow Clean intake and coils
MINIMAL HEAT	<ul style="list-style-type: none"> Insufficient removal of condensation (steam) Not enough steam pressure/ water temperature too low Intake air below design temperature 	<ul style="list-style-type: none"> Increase trap size Raise pressure for steam/increase water flow Increase steam pressure/increase water flow

XI. APPENDIX

A. Serial Network Connection

NOTE: THE AIR CURTAIN MUST HAVE BEEN ORDERED FROM THE FACTORY WITH THIS OPTION.

Contact the Factory for more information.

NOTE: These air curtains come standard with the **Berner AIR™** system (smart controller and app, includes BACnet capability), which allows multiple air curtains to be programmed and operated via the **Berner AIR App**.

See Section VII. OPERATING INSTRUCTIONS.

NOTE: ONLY AIR CURTAINS FROM THE SAME SERIES CAN BE NETWORKED TOGETHER. IF UNITS FROM DIFFERENT SERIES ARE NETWORKED AN ER61 WILL DISPLAY EVERY TIME A COMMAND IS ENTERED.

Serial Network Connection Operation

A serial cable connection must be made between all Intelliswitch™ controls of each air curtain to be linked. Once air curtains are linked all Menu settings made through any air curtain display or remote control will transfer to all other linked air curtains. Parameter changes made on any linked air curtain will update all other boards “live” upon menu selections.

1. All air curtains equipped with an Intelliswitch and the Serial Communication Option have two RJ11 connectors (telephone plug) located in the wiring compartment with the corresponding RJ11 socket (telephone jack) on each end. Serial cable(s) are shipped separately.
2. Once the air curtains are installed, serial (in-line) connect all units that are to be networked together using the serial cable(s). Connect cable to either RJ11 socket in the wiring compartment from unit to unit. For example, two units networked together require one cable and leaves an unused connector on each unit. Three units networked together requires two serial cables, leaves two units with one connector unused and one unit with both connectors used.
3. The wiring diagram in the wiring compartment or on the bottom cover of each air curtain illustrates the provision where the serial cable is connected to network additional air curtains.
4. Once all air curtains are serial connected together and powered, the units can be operated from any hand held remote or display of a unit on the network. All program settings are included in the installation instructions shipped with the air curtain.
5. If the air curtains were ordered with the Berner AIR, when connected to the local Wi-Fi network, the air curtains can be programmed from a smart phone using the Berner AIR™ App.

Serial Network Connection - Settings

When units with the Intelliswitch™ are operated on a Serial network there are three options under the Programming Menu that manage how they interact with each other.

- Door Switch (door)
- Thermostat (temp)
- Stop (Stop)

Each option can be set to “ind” or “ALL”.

“ind” = the option only is activated on this unit or independent of the other units

“ALL” = the option activates ALL units on the network

1. To access the Serial Network Connection options hold the "+" for 5 seconds and “Pro” will display.
2. Use the up/down arrows to locate the desired option (door/temp/Stby).
3. When located, press the "√" to enter setting.
4. Use the +/- arrow to change the setting between “ind” and “ALL” and press "√" to accept. Press "√" to exit.

EXAMPLE: Door Switch function

If set to independent, the door switch connected to a unit will only activate that unit. If set to ALL, all of the connected units set to ALL will activate.

EXAMPLE: Thermostat function

If set to independent, the thermostat connected to a unit will only activate that unit. If set to ALL, all of the connected units set to ALL will activate.

EXAMPLE: Stop function

If set to independent, when STOP is pressed only the unit where STOP is pressed will stop. If set to ALL, all of the connected units set to ALL will stop.

B. Remote Wall Mounted Touchscreen

1. If the unit was ordered with a remote wall mounted touchscreen, the air curtain will come pre-wired with a power-over-ethernet (PoE) connection in the wiring compartment to power the tablet. Connect a CAT 5 ethernet cable for low voltage power with a max. length of 300' (provided by others).

C. BACnet-IP Integration

If this unit is equipped with the Berner AIR™ (smart controller & app), then it is BACnet compatible.

1. To connect wirelessly to the Building Management System using BACnet-IP – download the Berner AIR App, pair the air curtain to the app and then in the settings menu select the BACnet option. Follow the prompts to configure the BACnet controller.
2. To connect via wire: this air curtain includes an ethernet connection in the wiring compartment to connect to the Building Management System via BACnet-IP. Connect a CAT 5 ethernet cable (provided by others). Once wired, download the Berner AIR™ App, pair the air curtain to the app and then in the settings menu select the BACnet option. Follow the prompts to configure the BACnet controller.

XII. WARRANTY

Berner International ("The Company") warrants all new equipment to be free of defects in workmanship and material for a period of five years (5 years) on unheated models and two years (2 years) on heated models from the original date of shipment, provided the equipment has been properly cared for, installed and operated in accordance with the limits specified on the nameplate and The Company's instructions. All warranted parts will be replaced at no charge for a period of six months from date the parts were shipped.

The Company will correct by repair or replacement, at its option and expense, any proven defects in said apparatus, subject to the above conditions, provided that immediate written notice of such defects is given to The Company. The warranty does not include any labor incurred for the removal or installation of defective part(s). The Company reserves the right to inspect, or have inspected by a qualified representative, any apparatus at the place of installation before authorizing repair or replacement. Repair or replacement will be made F.O.B. factory with any applicable transportation charges to be borne by the customer. Merchandise not of The Company's manufacture supplied in piece, or in component assemblies, is not covered by the above warranty, but The Company will give the customer the benefit of any adjustment as made with the Manufacturer.

This warranty is void if the apparatus has been tampered with in any way or shows evidence of misuse.

The Company will not assume any expense or liability for repairs made outside its factory without proper written consent from its service manager, nor for any transportation charges on apparatus returned to the factory without written authorization by The Company.

Nothing in the above warranty provisions, however, shall impose any liability or obligation of any type, nature or description upon Berner International if Berner has not received payment in full for the apparatus in question.

THERE ARE NO WARRANTIES WHICH EXTEND BEYOND THE DESCRIPTION ON THE FACE HEREOF INCLUDING THE IMPLIED WARRANTY OF MERCHANTABILITY AND FITNESS FOR A PARTICULAR PURPOSE.

LIMITATION OF DAMAGES

Notwithstanding anything to the contrary above, customer's exclusive remedy for any and all losses or damages resulting from the sale of The Company's equipment under this agreement, including but not limited to, any allegations of breach of warranty, breach of contract, negligence or strict liability, shall be limited, at The Company's option, to either the return of the purchase price or the replacement of the particular equipment for which a claim is made and proved. In no event shall The Company be liable for any special, consequential, incidental or indirect losses or damages from the sale of The Company's equipment under this agreement.

SERIAL NUMBER

DATE PURCHASED



Saving energy and creating healthy, comfortable environments

BERNER INTERNATIONAL
New Castle, Pennsylvania

724-658-3551 • 1-800-245-4455 • www.Berner.com

Berner reserves the right to alter specifications without prior notice.