

Zehnder Rittling Element and Enclosure



Installation, Operation and Maintenance

Heating

Cooling

Fresh Air

Clean Air



<u>Models</u>	1
<u>Dimensions and data</u>	5
<u>Design data</u>	26
<u>General information</u>	28
<u>Receiving</u>	28
<u>Safety considerations</u>	29
<u>Unpacking and preparation</u>	30
<u>Handling and installation</u>	30
<u>Hardware</u>	38
<u>Hot water connection</u>	39
<u>Start-up</u>	40
<u>Water system</u>	40
<u>Water treatment</u>	41
<u>Maintenance</u>	41
<u>Replacement parts</u>	42
<u>Equipment start-up checklist</u>	42
<u>Warranty</u>	43

IMPORTANT: Approved submittal documentation, specific to each project, supersedes the general guidelines contained within this document.

Enclosure models and arrangements

Regency

FF5/FF3 - Front grille

Applications:

Provide heat through front panel louvers when installations require heated air to be diffused away from exterior walls.

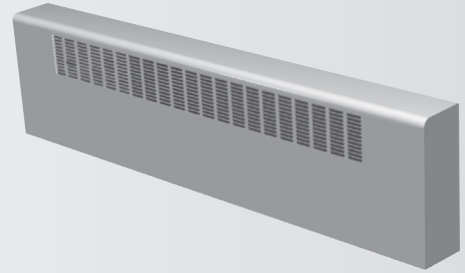

FR5/FR3 - Rounded grille

Applications:

When high heat output is demanded into room and along exterior walls. Appealing enclosure design allows heat to radiate through louvers rounded along top and front edge of cabinet.

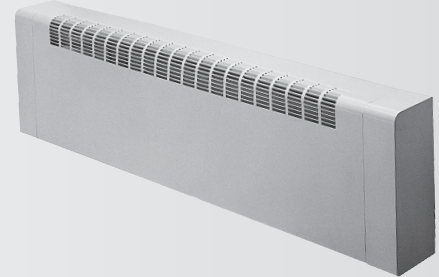

FT5/FT3 - Top grille

Applications:

Provide an even blanket of heated air through top louvers and emit radiant heat off the front of the cabinet. Ideal for exposed walls and large window areas.

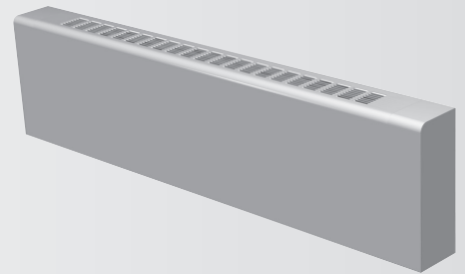

FS5/FS3 - Sloped grille

Applications:

Designed for high heat output through a sloped louvered outlet. Recommended to prevent enclosure from being used as shelf or step.

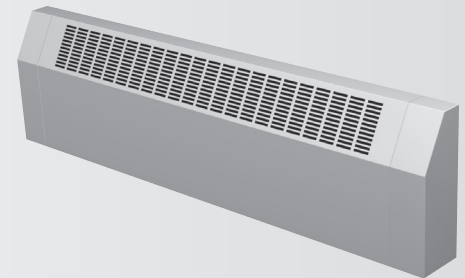

FSOS - Double sloped grille

Applications:

Double sloped panels provide required heat output when higher wall mounting is called for to restrict accessibility...such as in swimming pool areas and gymnasiums.

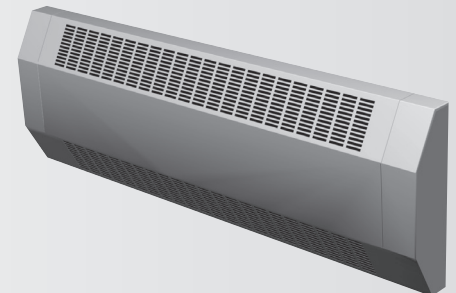

ETL - Pedestal

Applications:

When wall mounting is not an option, these models can be secured directly to the floor. Ceiling to floor windows would necessitate using this style of enclosure.

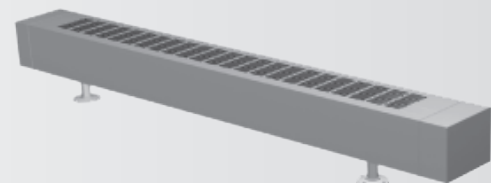

Enclosure models and arrangements

Security

S-SP5/PS5/PDS5/S-DSP5/S-TP5/S-FP5/S-RP5/PR5 - Perforated grille

Applications:

Rittling Security Series Enclosures are designed to provide extreme strength and durability when heating:

- Correctional facilities
- Healthcare institutions
- Apartment complexes
- Schools
- Other high-traffic or harsh environments

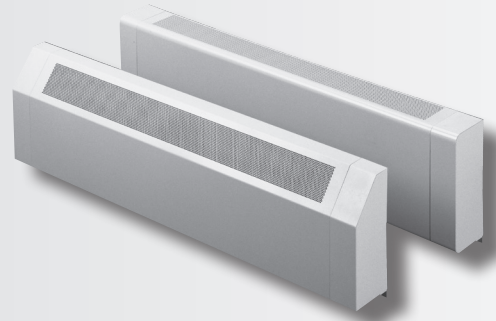

S-SL - Sloped grille

Applications:

Meet interior design specifications requiring consistent and even heat through conventional louvers and when security of enclosure is imperative.

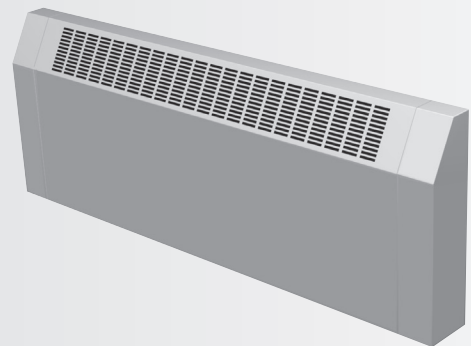

Enclosure models and arrangements

Architectural

BG5/IBG5/BGVL5/IBGVL5/BGHL5/IBGHL5 - Standard

Applications:

Zehnder Rittling's Standard Bargrille Enclosure provide high output in an attractive architectural design with a depth of 5-3/8".

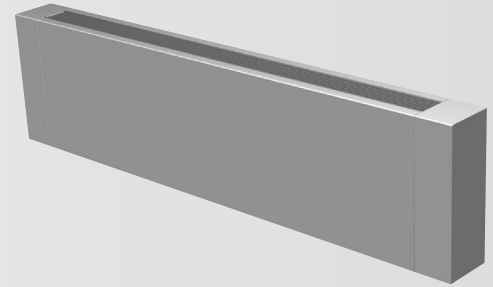

BG3/IBG3/BGVL3/IBGVL3/BGHL3/IBGHL3 - Low profile

Applications:

Zehnder Rittling's Low Profile Bargrille Enclosure provides an attractive architectural design with a slimline appearance and a depth of less than 4".

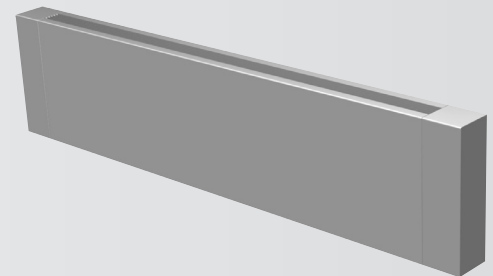

PBG5/PIBG5/PBG10/PIBG10 - Pedestal

Applications:

Zehnder Rittling's Pedestal Bargrille Enclosure offers a slimline appearance in a strong floor mounted enclosure.

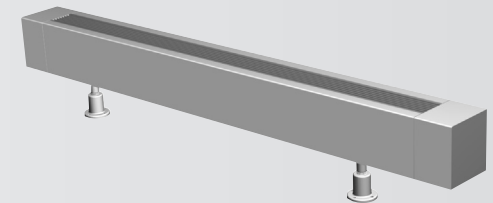

SBG5/SIBG5/SBGVL5/SIBGVL5 - Standard sloped top

Applications:

Zehnder Rittling's Sloped Top Bargrille Enclosure provides strong contemporary styling and high output. Available with a depth of 5-3/8" depth.

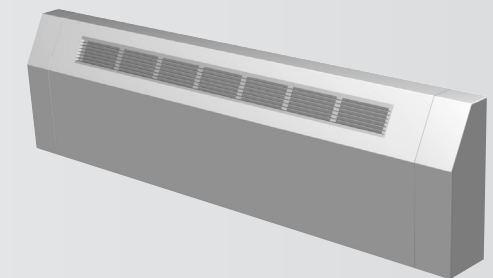

SBG3/SIBG3/SBGVL3/SIBGVL3 - Low profile sloped top

Applications:

Zehnder Rittling's Sloped Top Bargrille Enclosure provides strong contemporary styling and high output. Available with a depth of 3-15/16".

Enclosure models and arrangements Econoline

STEL - Sloped economy

Applications:

Econo-Line sloped top baseboard enclosures from Zehnder Rittling are an excellent choice for light commercial applications such as banks, offices, hospitals and housing renovations.

Econo-Line is designed to provide high heat output through a sloped louvered grille. The enclosures can accommodate eight types of Zehnder Rittling copper/aluminum finned tube with nominal diameters of 3/4, 1 or 1-1/4 inches, fins measuring 2-3/4 by 4 inches and fin spacing of 32, 40 or 48 per foot.

Enclosure sections are available in 15 lengths from 1 through 8 feet in 6 inch increments for a custom fit.

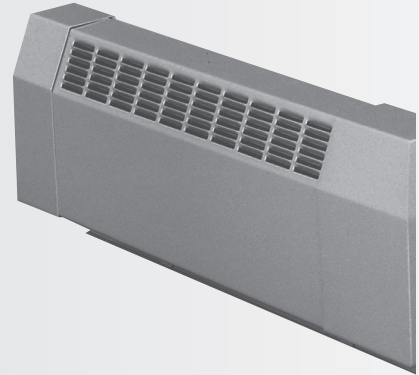

ETO and EXO - Economy

Applications:

For use with one, two, or three vertical rows of wall mounted finned tube.

ETO (top-louvered outlet) and EXO (expanded metal) enclosures slip securely over one, two or three vertical rows of wall-mounted finned tube. The tube is set in place in Zehnder Rittling's universal, cradle-type expansion brackets and lagged to the wall at the desired height. Made of sturdy, ribbed galvanized steel, these economical brackets permit 1-1/4 inches of finned tube expansion and are installed at intervals of 36 inches or less.

Featured in ETO and EXO enclosures, they accommodate any Zehnder Rittling finned tube with fins measuring 3-1/4" x 3-1/4" or 4-1/4" x 4-1/4".

(See our Finned Tube catalog for more information).

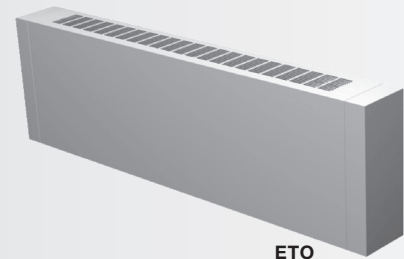

ETO

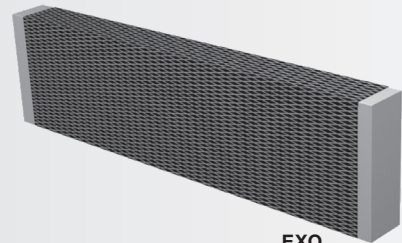

EXO

Dimensions and data

Regency, Flat top, front outlet enclosures

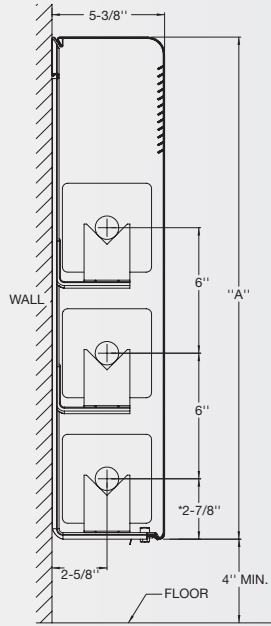

FF5			
Pipe size		Fin size	A
Steel	Copper		
N/A	3/4", 1", 1-1/4"	2-3/4" x 4"	14"
1", 1-1/4"	3/4", 1", 1-1/4"	3-1/4" x 3-1/4"	20"
1", 1-1/4", 2	3/4", 1", 1-1/4"	4-1/4" x 4-1/4"	24"

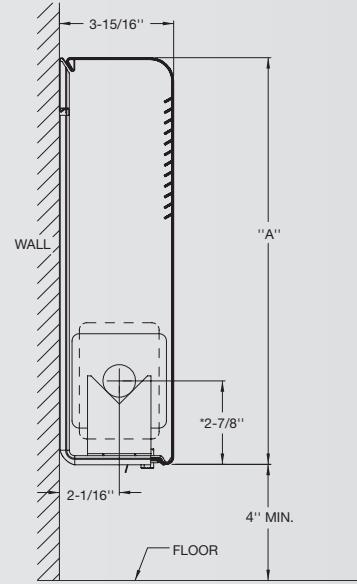

FF3			
Pipe size		Fin size	A
Steel	Copper		
N/A	3/4", 1", 1-1/4"	2-3/4" x 4"	8"
1", 1-1/4"	3/4", 1", 1-1/4"	3-1/4" x 3-1/4"	11"
			14"

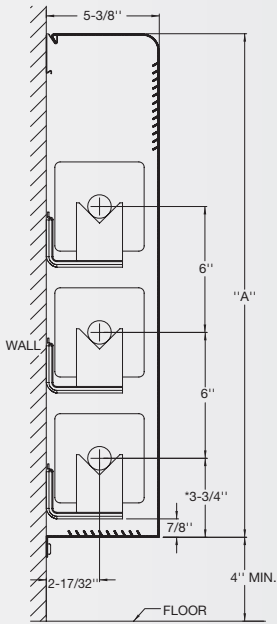

FFHL5			
Pipe size		Fin size	A
Steel	Copper		
N/A	3/4", 1", 1-1/4"	2-3/4" x 4"	14"
1", 1-1/4"	3/4", 1", 1-1/4"	3-1/4" x 3-1/4"	20"
1", 1-1/4", 2	3/4", 1", 1-1/4"	4-1/4" x 4-1/4"	24"

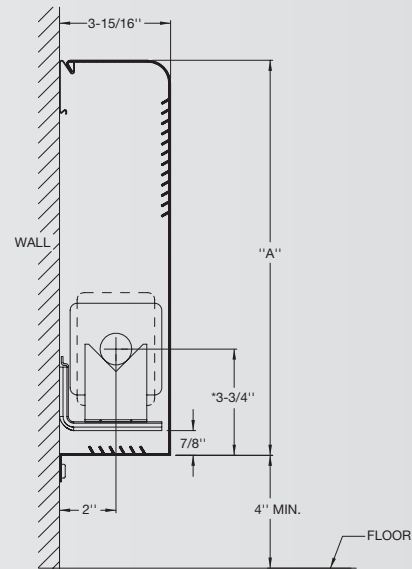

FFHL3			
Pipe size		Fin size	A
Steel	Copper		
N/A	3/4", 1", 1-1/4"	2-3/4" x 4"	11"
1", 1-1/4"	3/4", 1", 1-1/4"	3-1/4" x 3-1/4"	14"

Notes:

- *Centerlines are based on 1" copper tube.

Dimensions and data

Regency, Flat top, front outlet enclosures

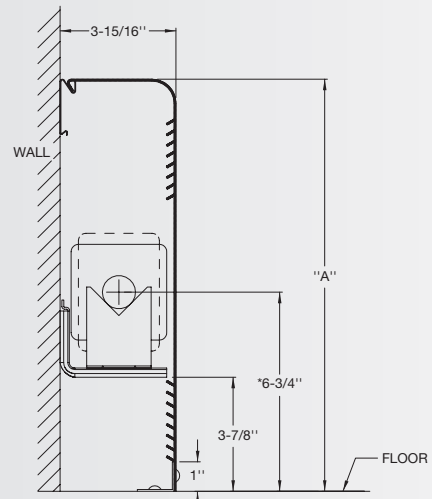
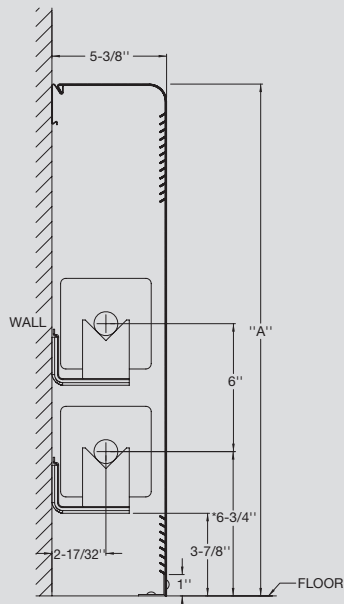

FFVL5			
Pipe size		Fin size	A
Steel	Copper		
N/A	3/4", 1", 1-1/4"	2-3/4" x 4"	14"
1", 1-1/4"	3/4", 1", 1-1/4"	3-1/4" x 3-1/4"	20"
1", 1-1/4", 2	3/4", 1", 1-1/4"	4-1/4" x 4-1/4"	24"

FFVL3			
Pipe size		Fin size	A
Steel	Copper		
N/A	3/4", 1", 1-1/4"	2-3/4" x 4"	14"
1", 1-1/4"	3/4", 1", 1-1/4"	3-1/4" x 3-1/4"	

Notes:

- *Centerlines are based on 1" copper tube.

Dimensions and data

Regency, Flat top, round outlet enclosures

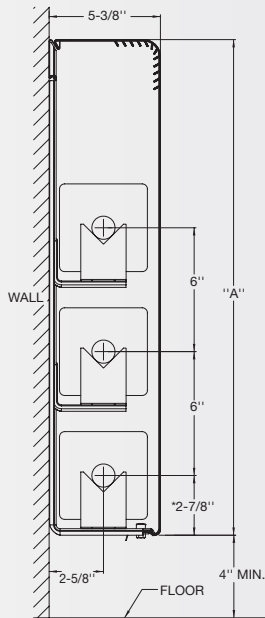

FR5			
Pipe size		Fin size	A
Steel	Copper		
N/A	3/4", 1", 1-1/4"	2-3/4" x 4"	14"
1", 1-1/4"	3/4", 1", 1-1/4"	3-1/4" x 3-1/4"	20"
1", 1-1/4", 2	3/4", 1", 1-1/4"	4-1/4" x 4-1/4"	24"

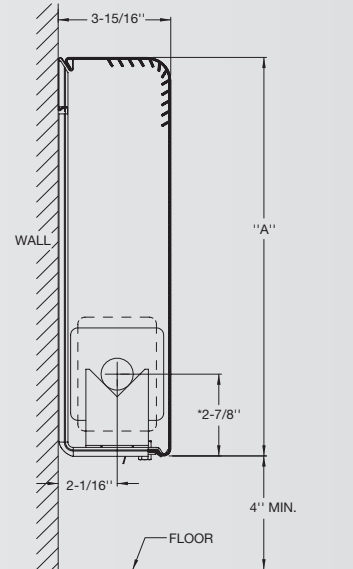

FR3			
Pipe size		Fin size	A
Steel	Copper		
N/A	3/4", 1", 1-1/4"	2-3/4" x 4"	8"
1", 1-1/4"	3/4", 1", 1-1/4"	3-1/4" x 3-1/4"	11"
			14"

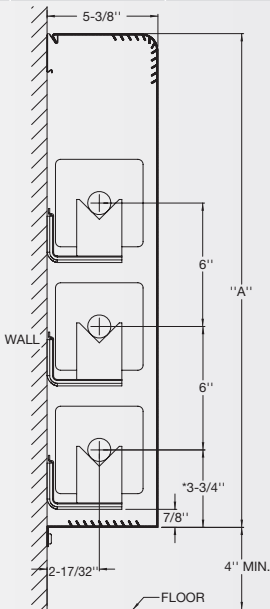

FRHL5			
Pipe size		Fin size	A
Steel	Copper		
N/A	3/4", 1", 1-1/4"	2-3/4" x 4"	14"
1", 1-1/4"	3/4", 1", 1-1/4"	3-1/4" x 3-1/4"	20"
1", 1-1/4", 2	3/4", 1", 1-1/4"	4-1/4" x 4-1/4"	24"

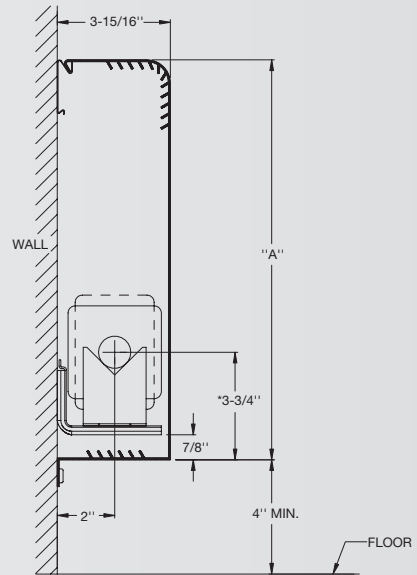

FRHL3			
Pipe size		Fin size	A
Steel	Copper		
N/A	3/4", 1", 1-1/4"	2-3/4" x 4"	8"
1", 1-1/4"	3/4", 1", 1-1/4"	3-1/4" x 3-1/4"	11"
			14"

Notes:

- *Centerlines are based on 1" copper tube.

Dimensions and data

Regency, Flat top, round outlet enclosures

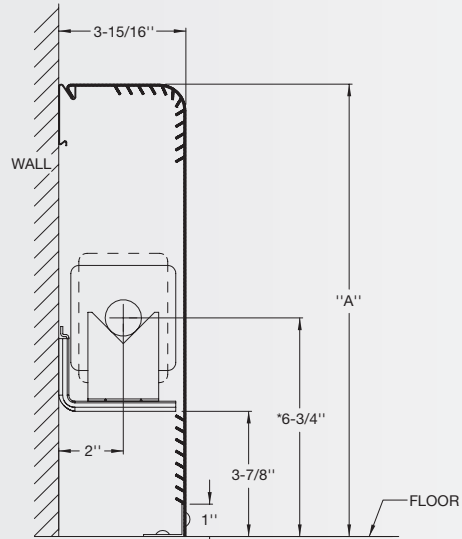
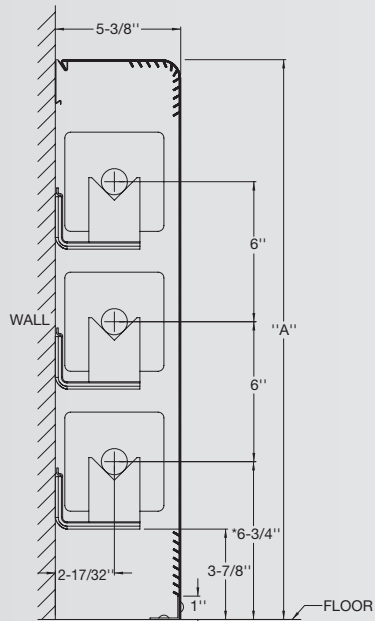

FRVL5			
Pipe size		Fin size	A
Steel	Copper		
N/A	3/4", 1", 1-1/4"	2-3/4" x 4"	14"
1", 1-1/4"	3/4", 1", 1-1/4"	3-1/4" x 3-1/4"	20"
1", 1-1/4", 2"	3/4", 1", 1-1/4"	4-1/4" x 4-1/4"	24"

FRVL3			
Pipe size		Fin size	A
Steel	Copper		
N/A	3/4", 1", 1-1/4"	2-3/4" x 4"	11"
1", 1-1/4"	3/4", 1", 1-1/4"	3-1/4" x 3-1/4"	14"

Notes:

- *Centerlines are based on 1" copper tube.

Dimensions and data

Regency, Flat top, top outlet enclosures

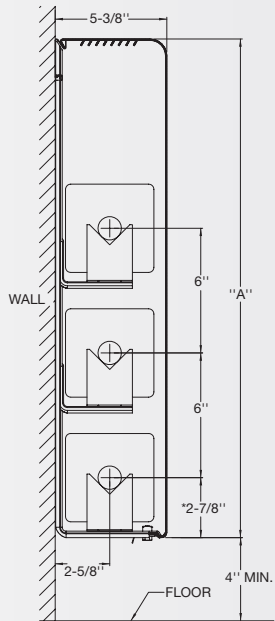

FT5			
Pipe size		Fin size	A
Steel	Copper		
N/A	3/4", 1", 1-1/4"	2-3/4" x 4"	14"
1", 1-1/4"	3/4", 1", 1-1/4"	3-1/4" x 3-1/4"	20"
1", 1-1/4", 2	3/4", 1", 1-1/4"	4-1/4" x 4-1/4"	24"

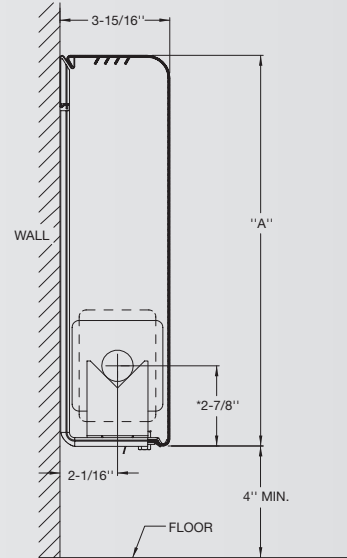

FT3			
Pipe size		Fin size	A
Steel	Copper		
N/A	3/4", 1", 1-1/4"	2-3/4" x 4"	8"
1", 1-1/4"	3/4", 1", 1-1/4"	3-1/4" x 3-1/4"	11"
			14"

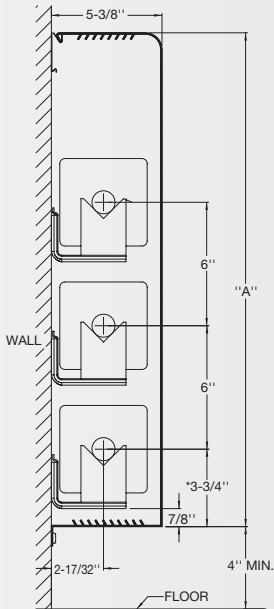

FTHL5			
Pipe size		Fin size	A
Steel	Copper		
N/A	3/4", 1", 1-1/4"	2-3/4" x 4"	14"
1", 1-1/4"	3/4", 1", 1-1/4"	3-1/4" x 3-1/4"	20"
1", 1-1/4", 2	3/4", 1", 1-1/4"	4-1/4" x 4-1/4"	24"

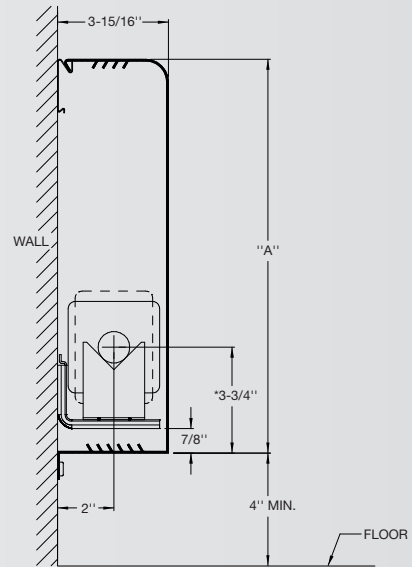

FTHL3			
Pipe size		Fin size	A
Steel	Copper		
N/A	3/4", 1", 1-1/4"	2-3/4" x 4"	8"
1", 1-1/4"	3/4", 1", 1-1/4"	3-1/4" x 3-1/4"	11"
			14"

Notes:

- *Centerlines are based on 1" copper tube.

Dimensions and data

Regency, Flat top, top outlet enclosures

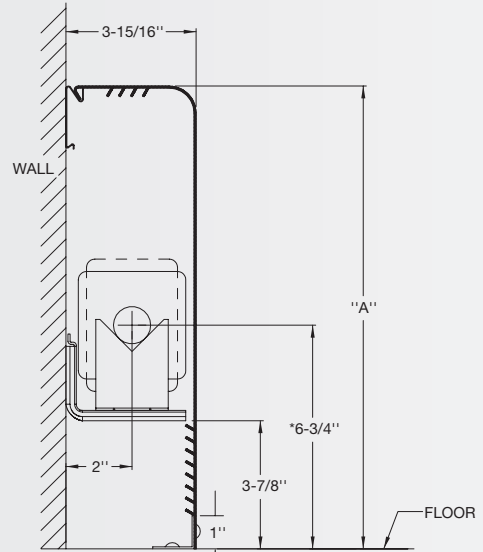
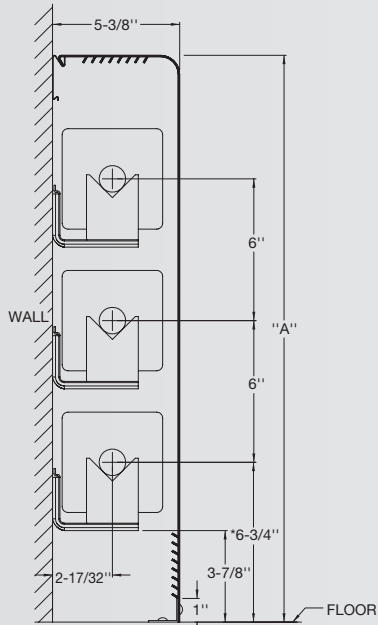

FTVL5			
Pipe size		Fin size	A
Steel	Copper		
N/A	3/4", 1", 1-1/4"	2-3/4" x 4"	14"
1", 1-1/4"	3/4", 1", 1-1/4"	3-1/4" x 3-1/4"	20"
1", 1-1/4", 2"	3/4", 1", 1-1/4"	4-1/4" x 4-1/4"	24"

FTVL3			
Pipe size		Fin size	A
Steel	Copper		
N/A	3/4", 1", 1-1/4"	2-3/4" x 4"	11"
1", 1-1/4"	3/4", 1", 1-1/4"	3-1/4" x 3-1/4"	14"

Notes:

- *Centerlines are based on 1" copper tube.

Dimensions and data

Regency, Slope top, front outlet enclosures

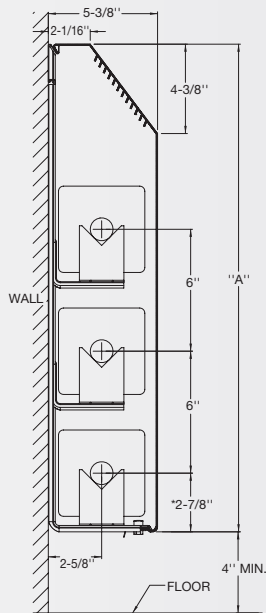

FS5			
Pipe size		Fin size	A
Steel	Copper		
N/A	3/4", 1", 1-1/4"	2-3/4" x 4"	14"
1", 1-1/4"	3/4", 1", 1-1/4"	3-1/4" x 3-1/4"	20"
1", 1-1/4", 2	3/4", 1", 1-1/4"	4-1/4" x 4-1/4"	24"

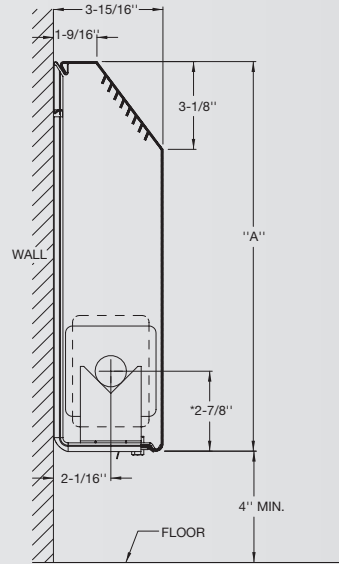

FS3			
Pipe size		Fin size	A
Steel	Copper		
N/A	3/4", 1", 1-1/4"	2-3/4" x 4"	8"
1", 1-1/4"	3/4", 1", 1-1/4"	3-1/4" x 3-1/4"	11"
			14"

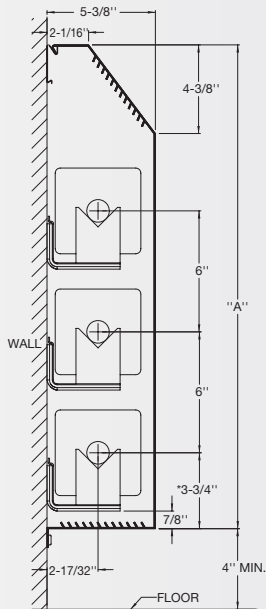

FS5L5			
Pipe size		Fin size	A
Steel	Copper		
N/A	3/4", 1", 1-1/4"	2-3/4" x 4"	14"
1", 1-1/4"	3/4", 1", 1-1/4"	3-1/4" x 3-1/4"	20"
1", 1-1/4", 2	3/4", 1", 1-1/4"	4-1/4" x 4-1/4"	24"

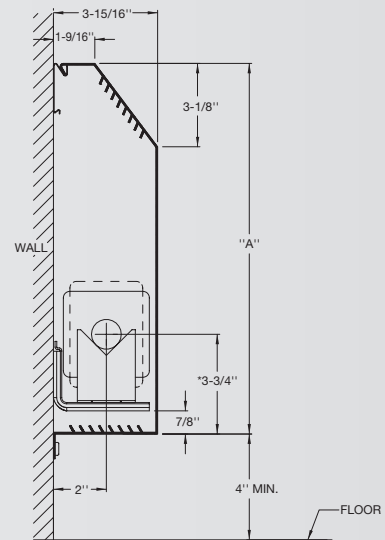

FS3L3			
Pipe size		Fin size	A
Steel	Copper		
N/A	3/4", 1", 1-1/4"	2-3/4" x 4"	11"
1", 1-1/4"	3/4", 1", 1-1/4"	3-1/4" x 3-1/4"	14"

Notes:

- *Centerlines are based on 1" copper tube.

Dimensions and data

Regency, Slope top, front outlet enclosures

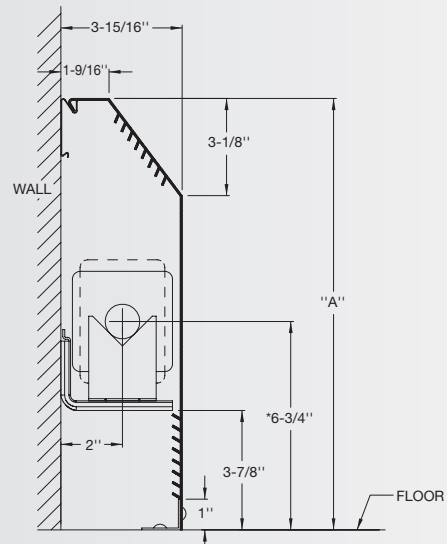
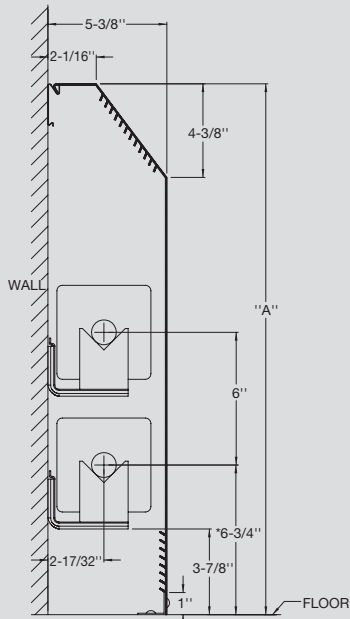

FSVL5			
Pipe size		Fin size	A
Steel	Copper		
N/A	3/4", 1", 1-1/4"	2-3/4" x 4"	14"
1", 1-1/4"	3/4", 1", 1-1/4"	3-1/4" x 3-1/4"	20"
1", 1-1/4", 2"	3/4", 1", 1-1/4"	4-1/4" x 4-1/4"	24"

FSVL3			
Pipe size		Fin size	A
Steel	Copper		
N/A	3/4", 1", 1-1/4"	2-3/4" x 4"	14"
1", 1-1/4"	3/4", 1", 1-1/4"	3-1/4" x 3-1/4"	

Notes:

- *Centerlines are based on 1" copper tube.

Dimensions and data

Regency, Double slope enclosures

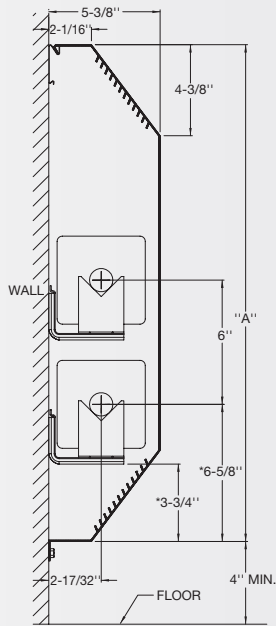

FSOS5			
Pipe size		Fin size	A
Steel	Copper		
N/A	3/4", 1", 1-1/4"	2-3/4" x 4"	18"
1", 1-1/4"	3/4", 1", 1-1/4"	3-1/4" x 3-1/4"	
1", 1-1/4", 2	3/4", 1", 1-1/4"	4-1/4" x 4-1/4"	24"

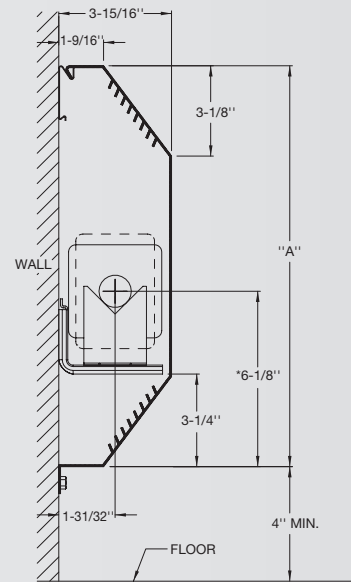

FSOS3			
Pipe size		Fin size	A
Steel	Copper		
N/A	3/4", 1", 1-1/4"	2-3/4" x 4"	14"
1", 1-1/4"	3/4", 1", 1-1/4"	3-1/4" x 3-1/4"	

Notes:

- *Centerlines are based on 1" copper tube.

Dimensions and data

Regency, Pedestal enclosures

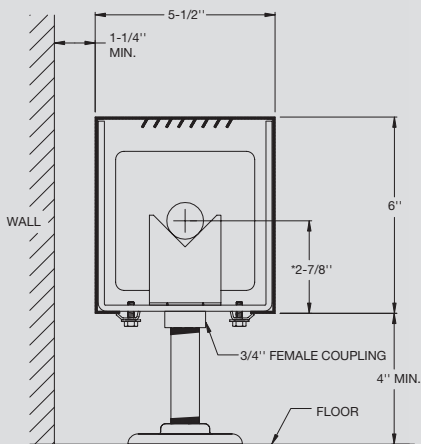

ETL5
One column, one row style

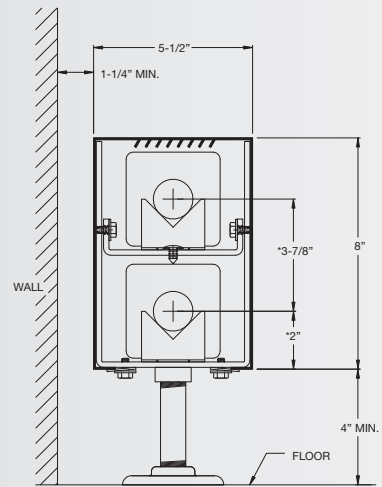

ETL5
One column, one row plus return style

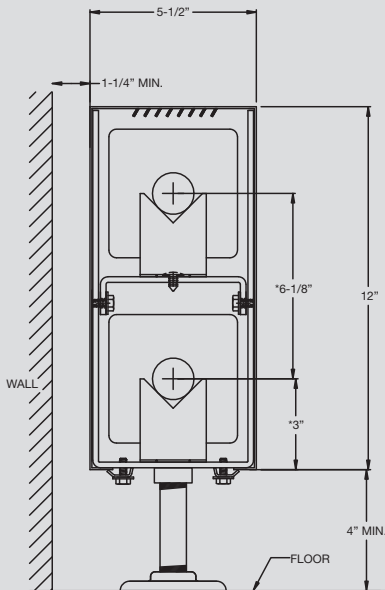

ETL5
One column, two row style

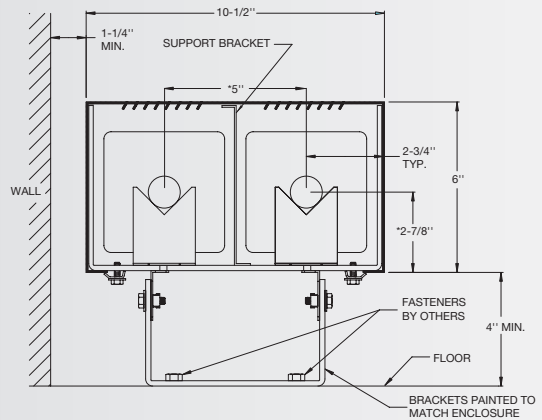

ETL10
Two column, one row style

Notes:

- *Centerlines are based on 1" copper tube.

Dimensions and data

Security, Steel Enclosures: Perforated

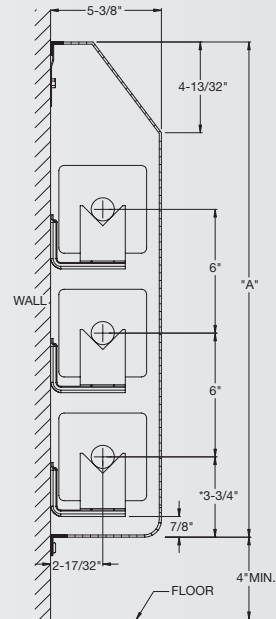
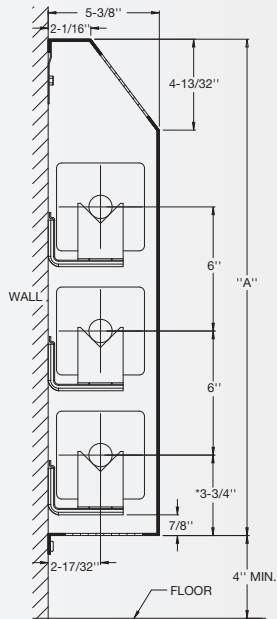

S-SP5			
Pipe size		Fin size	A
Steel	Copper		
N/A	3/4", 1", 1-1/4"	2-3/4" x 4"	12"
1", 1-1/4", 2	3/4", 1", 1-1/4"	3-1/4" x 3-1/4"	18"
1", 1-1/4", 2	3/4", 1", 1-1/4"	4-1/4" x 4-1/4"	24"

PS5			
Pipe size		Fin size	A
Steel	Copper		
N/A	3/4", 1", 1-1/4"	2-3/4" x 4"	12"
1", 1-1/4", 2	3/4", 1", 1-1/4"	3-1/4" x 3-1/4"	18"
1", 1-1/4", 2	3/4", 1", 1-1/4"	4-1/4" x 4-1/4"	24"

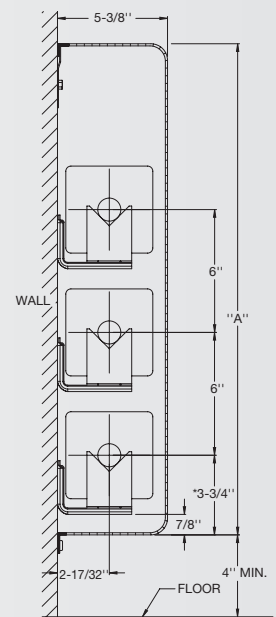
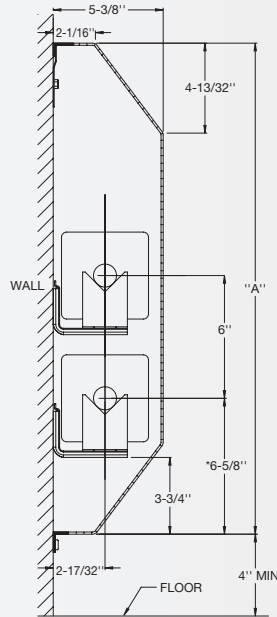

S-DSP5, PDS5 (shown)			
Pipe size		Fin size	A
Steel	Copper		
N/A	3/4", 1", 1-1/4"	2-3/4" x 4"	12"
1", 1-1/4", 2	3/4", 1", 1-1/4"	3-1/4" x 3-1/4"	18"
1", 1-1/4", 2	3/4", 1", 1-1/4"	4-1/4" x 4-1/4"	24"

S-TP5, S-FP5, S-RP5, PR5 (shown)			
Pipe size		Fin size	A
Steel	Copper		
N/A	3/4", 1", 1-1/4"	2-3/4" x 4"	12"
1", 1-1/4", 2	3/4", 1", 1-1/4"	3-1/4" x 3-1/4"	18"
1", 1-1/4", 2	3/4", 1", 1-1/4"	4-1/4" x 4-1/4"	24"

Notes:

- *Centerlines are based on 1" copper tube.

Dimensions and data

Security, Steel Enclosures: Louvered

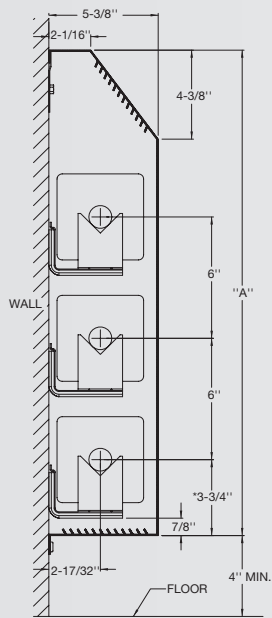

S-SL			
Pipe size		Fin size	A
Steel	Copper		
N/A	3/4", 1", 1-1/4"	2-3/4" x 4"	12"
1", 1-1/4"	3/4", 1", 1-1/4"	3-1/4" x 3-1/4"	18"
1", 1-1/4", 2	3/4", 1", 1-1/4"	4-1/4" x 4-1/4"	24"

Notes:

- *Centerlines are based on 1" copper tube.

Dimensions and data

Architectural, Bargrille

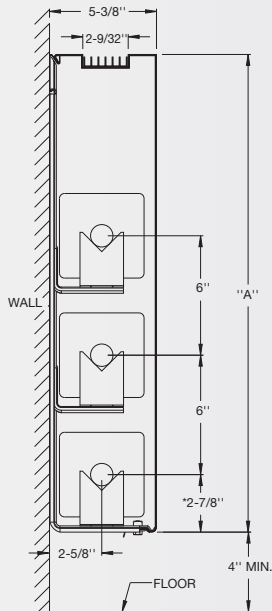

BG5			
Pipe size		Fin size	A
Steel	Copper		
N/A	3/4", 1", 1-1/4"	2-3/4" x 4"	14"
1", 1-1/4"	3/4", 1", 1-1/4"	3-1/4" x 3-1/4"	20"
1", 1-1/4", 2	3/4", 1", 1-1/4"	4-1/4" x 4-1/4"	24"

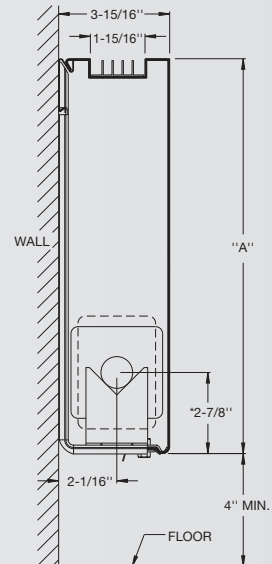

BG3			
Pipe size		Fin size	A
Steel	Copper		
N/A	3/4", 1", 1-1/4"	2-3/4" x 4"	8"
1", 1-1/4"	3/4", 1", 1-1/4"	3-1/4" x 3-1/4"	11"
			14"

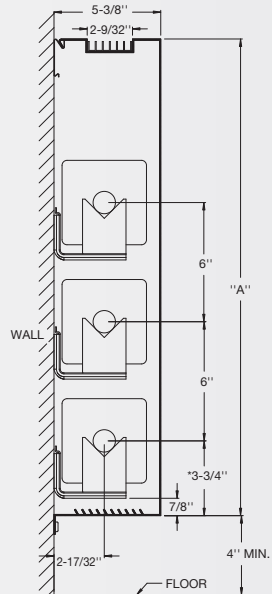

BGHL5			
Pipe size		Fin size	A
Steel	Copper		
N/A	3/4", 1", 1-1/4"	2-3/4" x 4"	14"
1", 1-1/4"	3/4", 1", 1-1/4"	3-1/4" x 3-1/4"	20"
1", 1-1/4", 2	3/4", 1", 1-1/4"	4-1/4" x 4-1/4"	24"

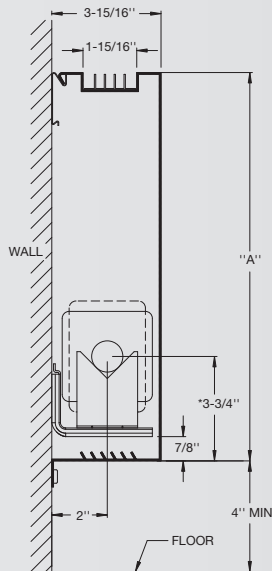

BGHL3			
Pipe size		Fin size	A
Steel	Copper		
N/A	3/4", 1", 1-1/4"	2-3/4" x 4"	8"
1", 1-1/4"	3/4", 1", 1-1/4"	3-1/4" x 3-1/4"	11"
			14"

Note:

■ *Centerlines are based on 1" copper tube

Dimensions and data

Architectural, Bargrille

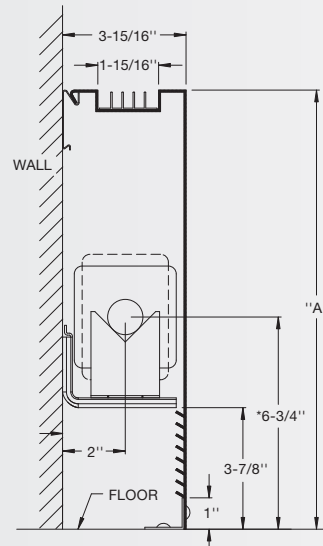
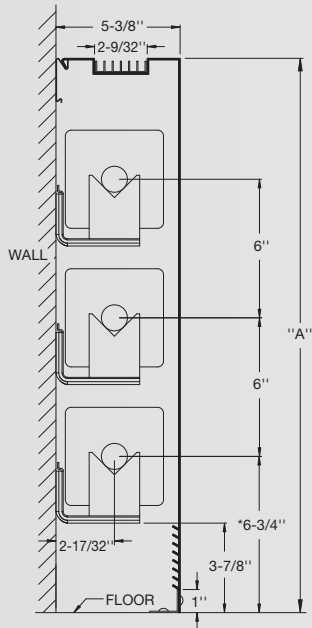

BGVL5			
Pipe size		Fin size	A
Steel	Copper		
N/A	3/4", 1", 1-1/4"	2-3/4" x 4"	14"
1", 1-1/4"	3/4", 1", 1-1/4"	3-1/4" x 3-1/4"	20"
1", 1-1/4", 2"	3/4", 1", 1-1/4"	4-1/4" x 4-1/4"	24"

BGVL3			
Pipe size		Fin size	A
Steel	Copper		
N/A	3/4", 1", 1-1/4"	2-3/4" x 4"	8"
			11"
1", 1-1/4"	3/4", 1", 1-1/4"	3-1/4" x 3-1/4"	14"

Note:

- *Centerlines are based on 1" copper tube

Dimensions and data

Architectural, Imperial bargrille

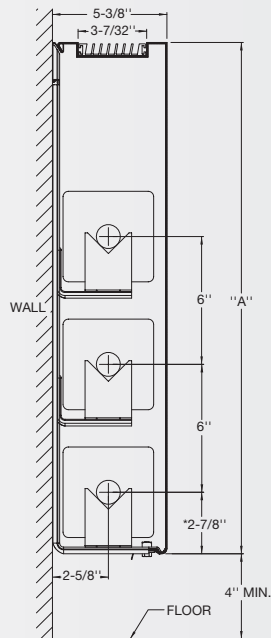

IBG5			
Pipe size		Fin size	A
Steel	Copper		
N/A	3/4", 1", 1-1/4"	2-3/4" x 4"	14"
1", 1-1/4"	3/4", 1", 1-1/4"	3-1/4" x 3-1/4"	20"
1", 1-1/4", 2	3/4", 1", 1-1/4"	4-1/4" x 4-1/4"	24"

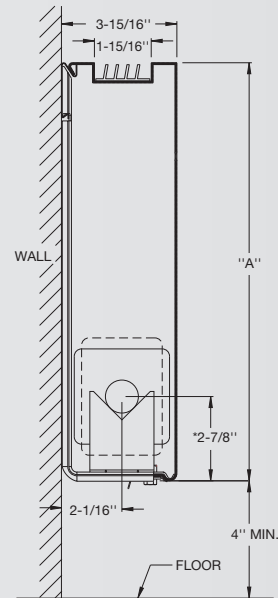

IBG3			
Pipe size		Fin size	A
Steel	Copper		
N/A	3/4", 1", 1-1/4"	2-3/4" x 4"	8"
1", 1-1/4"	3/4", 1", 1-1/4"	3-1/4" x 3-1/4"	11"
			14"

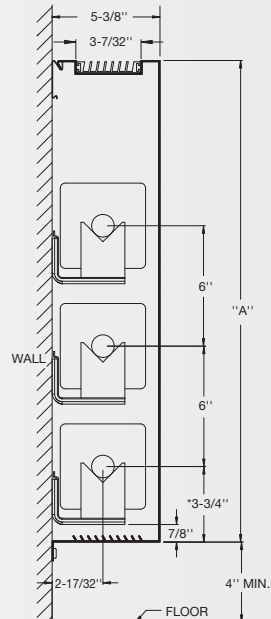

IBGHL5			
Pipe size		Fin size	A
Steel	Copper		
N/A	3/4", 1", 1-1/4"	2-3/4" x 4"	14"
1", 1-1/4"	3/4", 1", 1-1/4"	3-1/4" x 3-1/4"	20"
1", 1-1/4", 2	3/4", 1", 1-1/4"	4-1/4" x 4-1/4"	24"

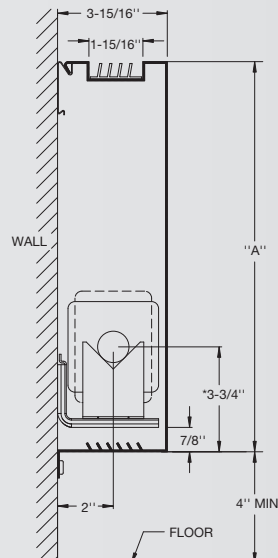

IBGHL3			
Pipe size		Fin size	A
Steel	Copper		
N/A	3/4", 1", 1-1/4"	2-3/4" x 4"	8"
			11"
1", 1-1/4"	3/4", 1", 1-1/4"	3-1/4" x 3-1/4"	14"

Note:

■ *Centerlines are based on 1" copper tube

Dimensions and data

Architectural, Imperial bargille

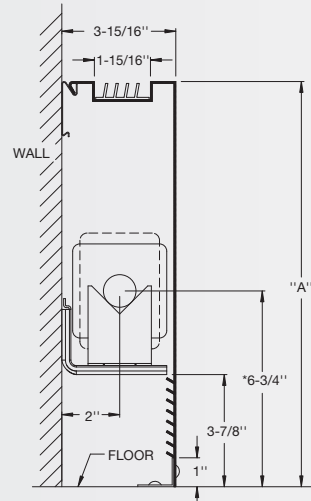
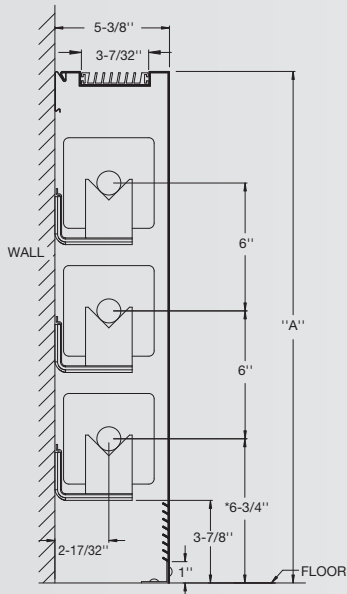

IBGVL5			
Pipe size		Fin size	A
Steel	Copper		
N/A	3/4", 1", 1-1/4"	2-3/4" x 4"	14"
1", 1-1/4"	3/4", 1", 1-1/4"	3-1/4" x 3-1/4"	20"
1", 1-1/4", 2	3/4", 1", 1-1/4"	4-1/4" x 4-1/4"	24"

IBGVL3			
Pipe size		Fin size	A
Steel	Copper		
N/A	3/4", 1", 1-1/4"	2-3/4" x 4"	8"
1", 1-1/4"	3/4", 1", 1-1/4"	3-1/4" x 3-1/4"	11"
1", 1-1/4"	3/4", 1", 1-1/4"	3-1/4" x 3-1/4"	14"

Note:

■ *Centerlines are based on 1" copper tube

Dimensions and data

Architectural, Pedestal

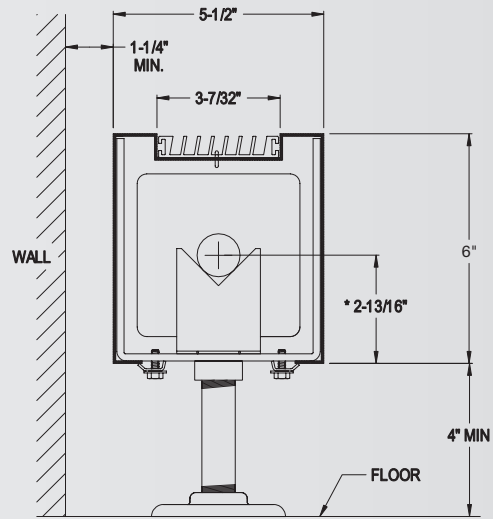
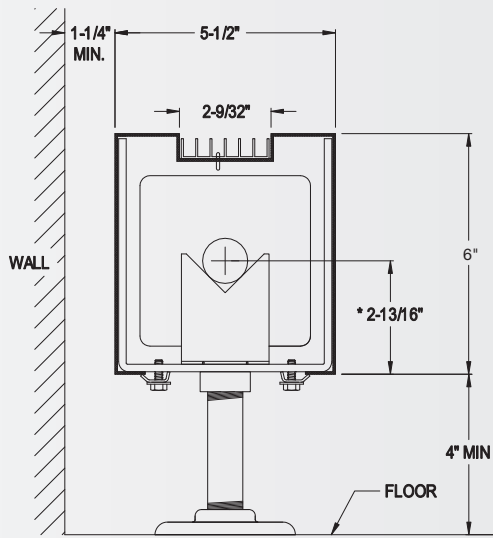

PBG5		
Pipe size		Fin size
Steel	Copper	
N/A	3/4", 1", 1-1/4"	2-3/4" x 4"
1", 1-1/4"	3/4", 1", 1-1/4"	3-1/4" x 3-1/4"
1", 1-1/4"	3/4", 1", 1-1/4"	4-1/4" x 4-1/4"

PIBG5		
Pipe size		Fin size
Steel	Copper	
N/A	3/4", 1", 1-1/4"	2-3/4" x 4"
1", 1-1/4"	3/4", 1", 1-1/4"	3-1/4" x 3-1/4"
1", 1-1/4"	3/4", 1", 1-1/4"	4-1/4" x 4-1/4"

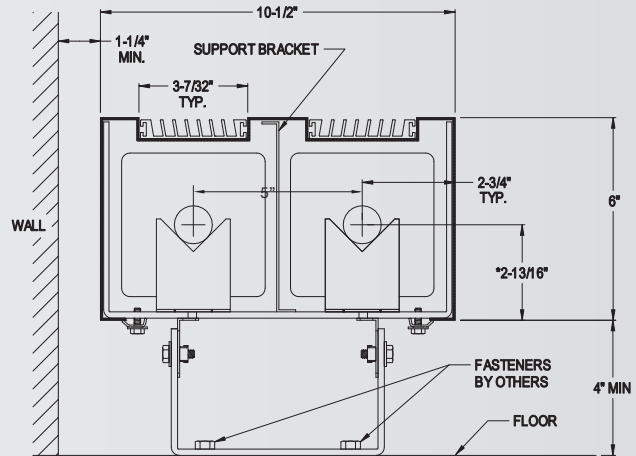
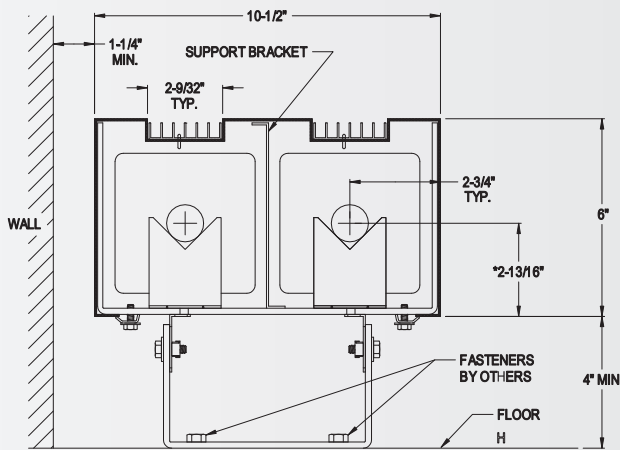

PBG10		
Pipe size		Fin size
Steel	Copper	
N/A	3/4", 1", 1-1/4"	2-3/4" x 4"
1", 1-1/4"	3/4", 1", 1-1/4"	3-1/4" x 3-1/4"
1", 1-1/4"	3/4", 1", 1-1/4"	4-1/4" x 4-1/4"

PIBG10		
Pipe size		Fin size
Steel	Copper	
N/A	3/4", 1", 1-1/4"	2-3/4" x 4"
1", 1-1/4"	3/4", 1", 1-1/4"	3-1/4" x 3-1/4"
1", 1-1/4"	3/4", 1", 1-1/4"	4-1/4" x 4-1/4"

Note:

■ *Centerlines are based on 1" copper tube

Dimensions and data

Architectural, Pedestal

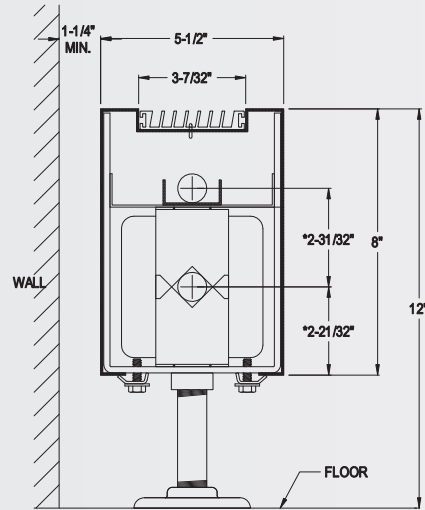
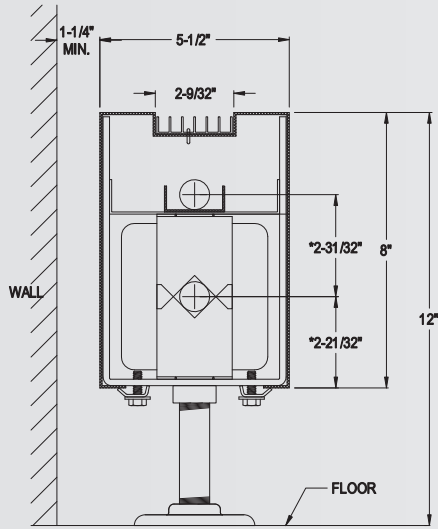

PBG5		
Pipe size		Fin size
Steel	Copper	
N/A	3/4", 1", 1-1/4"	2-3/4" x 4"
1", 1-1/4"	3/4", 1", 1-1/4"	3-1/4" x 3-1/4"
1", 1-1/4"	3/4", 1", 1-1/4"	4-1/4" x 4-1/4"

PIBG5		
Pipe size		Fin size
Steel	Copper	
N/A	3/4", 1", 1-1/4"	2-3/4" x 4"
1", 1-1/4"	3/4", 1", 1-1/4"	3-1/4" x 3-1/4"
1", 1-1/4"	3/4", 1", 1-1/4"	4-1/4" x 4-1/4"

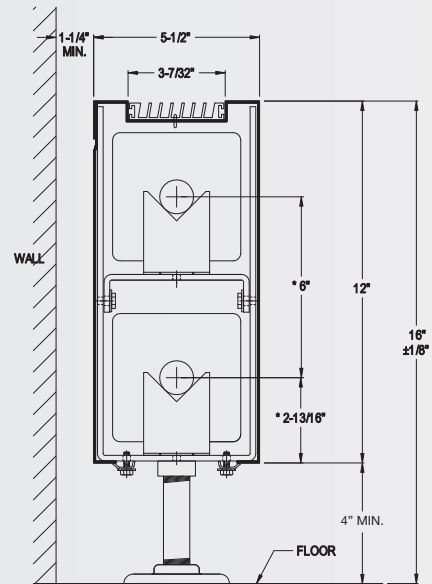
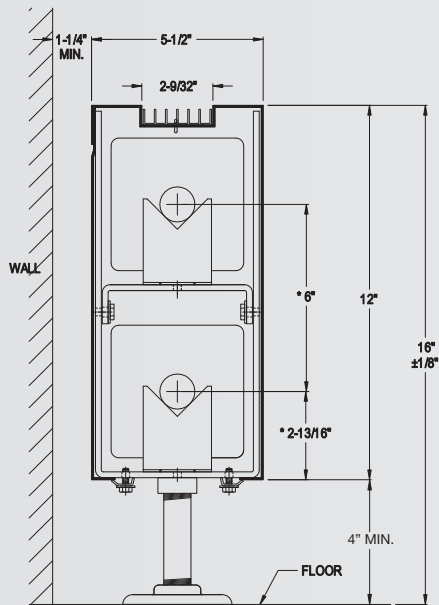

PBG5		
Pipe size		Fin size
Steel	Copper	
N/A	3/4", 1", 1-1/4"	2-3/4" x 4"
1", 1-1/4"	3/4", 1", 1-1/4"	3-1/4" x 3-1/4"
1", 1-1/4"	3/4", 1", 1-1/4"	4-1/4" x 4-1/4"

PIBG5		
Pipe size		Fin size
Steel	Copper	
N/A	3/4", 1", 1-1/4"	2-3/4" x 4"
1", 1-1/4"	3/4", 1", 1-1/4"	3-1/4" x 3-1/4"
1", 1-1/4"	3/4", 1", 1-1/4"	4-1/4" x 4-1/4"

Note:

- *Centerlines are based on 1" copper tube

Dimensions and data

Architectural, Sloped top

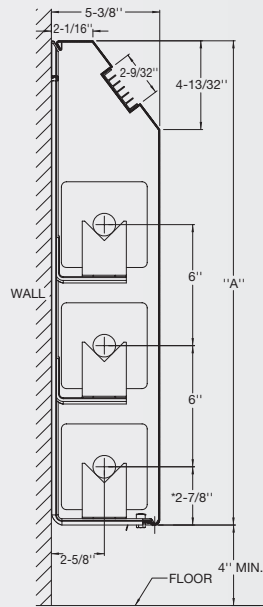

SBG5			
Pipe size		Fin size	A
Steel	Copper		
N/A	3/4", 1", 1-1/4"	2-3/4" x 4"	14"
1", 1-1/4"	3/4", 1", 1-1/4"	3-1/4" x 3-1/4"	20"
1", 1-1/4", 2	3/4", 1", 1-1/4"	4-1/4" x 4-1/4"	24"

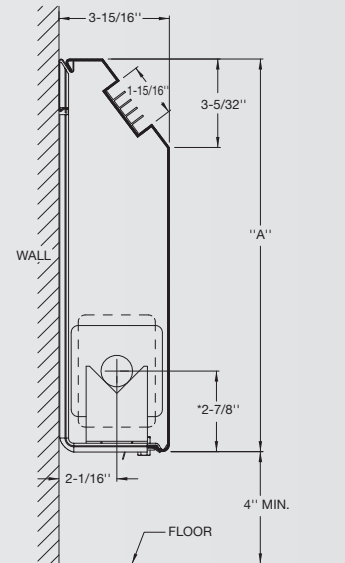

SBG3			
Pipe size		Fin size	A
Steel	Copper		
N/A	3/4", 1", 1-1/4"	2-3/4" x 4"	8"
			11"
1", 1-1/4"	3/4", 1", 1-1/4"	3-1/4" x 3-1/4"	14"

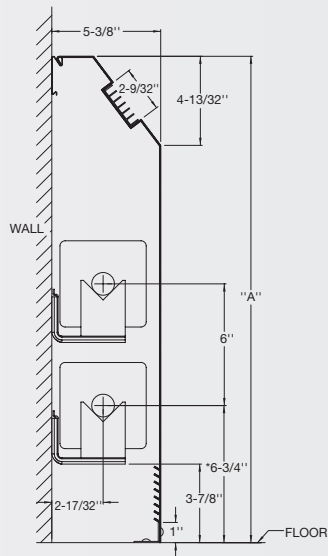

SBGVL5			
Pipe size		Fin size	A
Steel	Copper		
N/A	3/4", 1", 1-1/4"	2-3/4" x 4"	14"
1", 1-1/4"	3/4", 1", 1-1/4"	3-1/4" x 3-1/4"	20"
1", 1-1/4", 2	3/4", 1", 1-1/4"	4-1/4" x 4-1/4"	24"

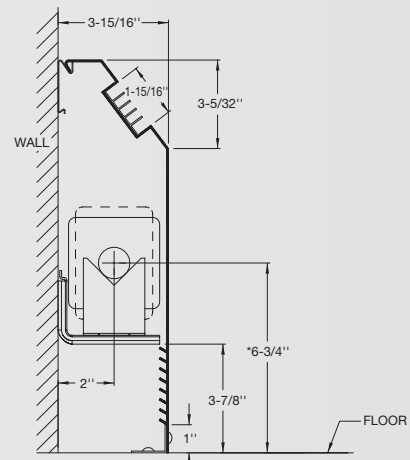

SBGVL3			
Pipe size		Fin size	A
Steel	Copper		
N/A	3/4", 1", 1-1/4"	2-3/4" x 4"	14"
1", 1-1/4"	3/4", 1", 1-1/4"	3-1/4" x 3-1/4"	14"

Note:

■ *Centerlines are based on 1" copper tube

Dimensions and data

Architectural, Sloped top

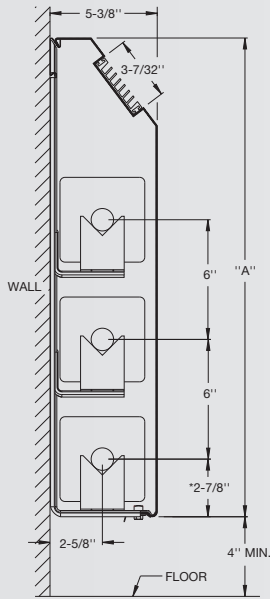

SIBG5			
Pipe size		Fin size	A
Steel	Copper		
N/A	3/4", 1", 1-1/4"	2-3/4" x 4"	14"
1", 1-1/4"	3/4", 1", 1-1/4"	3-1/4" x 3-1/4"	20"
1", 1-1/4", 2"	3/4", 1", 1-1/4"	4-1/4" x 4-1/4"	24"

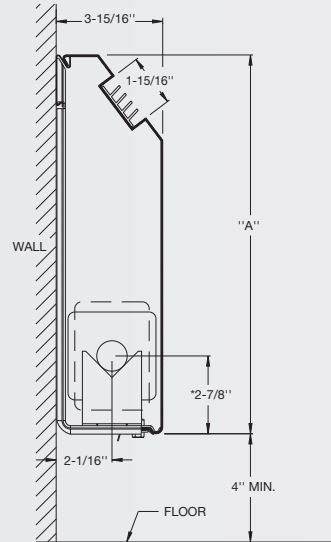

SIBG3			
Pipe size		Fin size	A
Steel	Copper		
N/A	3/4", 1", 1-1/4"	2-3/4" x 4"	8"
1", 1-1/4"	3/4", 1", 1-1/4"	3-1/4" x 3-1/4"	11"
			14"

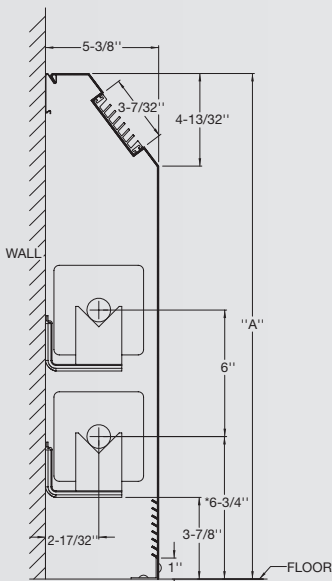

SIBGVL5			
Pipe size		Fin size	A
Steel	Copper		
N/A	3/4", 1", 1-1/4"	2-3/4" x 4"	14"
1", 1-1/4"	3/4", 1", 1-1/4"	3-1/4" x 3-1/4"	20"
1", 1-1/4", 2"	3/4", 1", 1-1/4"	4-1/4" x 4-1/4"	24"

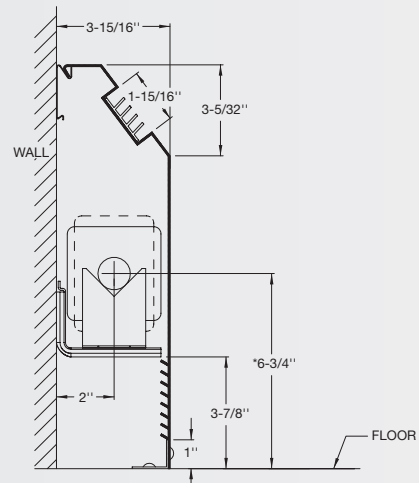

SIBGVL3			
Pipe size		Fin size	A
Steel	Copper		
N/A	3/4", 1", 1-1/4"	2-3/4" x 4"	14"
1", 1-1/4"	3/4", 1", 1-1/4"	3-1/4" x 3-1/4"	14"

Note:

■ *Centerlines are based on 1" copper tube

Dimensions and data Econo-Line, ETO, EXO

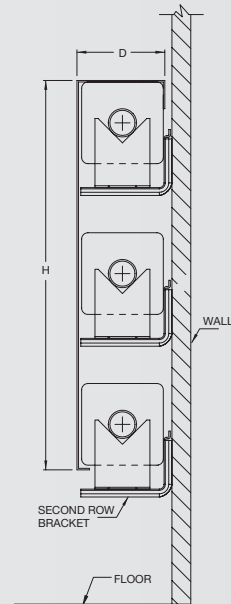
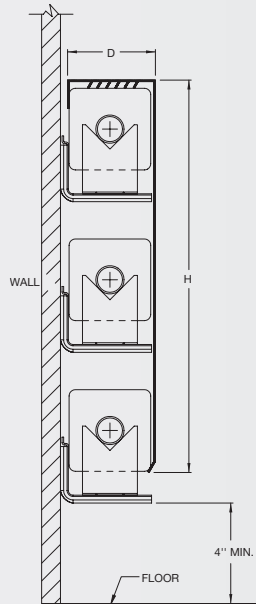

ETO			
Fin sizes for finned tube*	Rows of finned tube	D (depth)	H (height)
3-1/4" x 3-1/4"	1	3-1/2"	3-5/8"
	2		9-5/8"
	3		15-5/8"
4-1/4" x 4-1/4"	1	4-1/2"	4-5/8"
	2		10-5/8"
	3		16-5/8"

EXO			
Fin sizes for finned tube*	Rows of finned tube	D (depth)	H (height)
3-1/4" x 3-1/4"	1	3-1/2"	3-1/2"
	2		9-1/2"
	3		15-1/2"
4-1/4" x 4-1/4"	1	4-1/2"	4-1/2"
	2		10-1/2"
	3		16-1/2"

Note:

- *Consult factory to fit tube with 2-3/4" x 4" fins.

Econo-Line, Sloped economy STEL

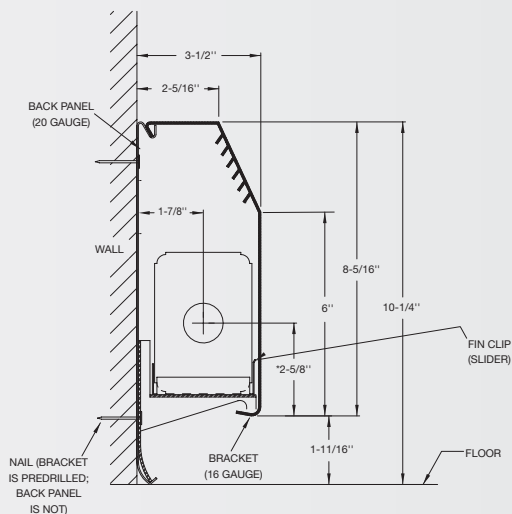

Design data

The effects of water velocity on finned tube output

The Institute of Boiler and Radiator Manufacturers sponsored a test program at the University of Illinois to determine the effect of water velocity on heat output of various sizes of finned tubed element.

The results of this test show that when the water velocity falls below 0.4 f.p.s., the flow changes from turbulent to streamline. With systems designed at water velocities below this point the output cannot be accurately predicted so should always be avoided.

Figure 1 shows rating factors that can be utilized when the water velocity falls below 3 f.p.s.

It is recommended when designing low-load systems that the water velocity be a key factor in element selection.

For more information on this topic, please refer to the 1969 equipment volume of ASHRAE Guide and Data Book Page #393.

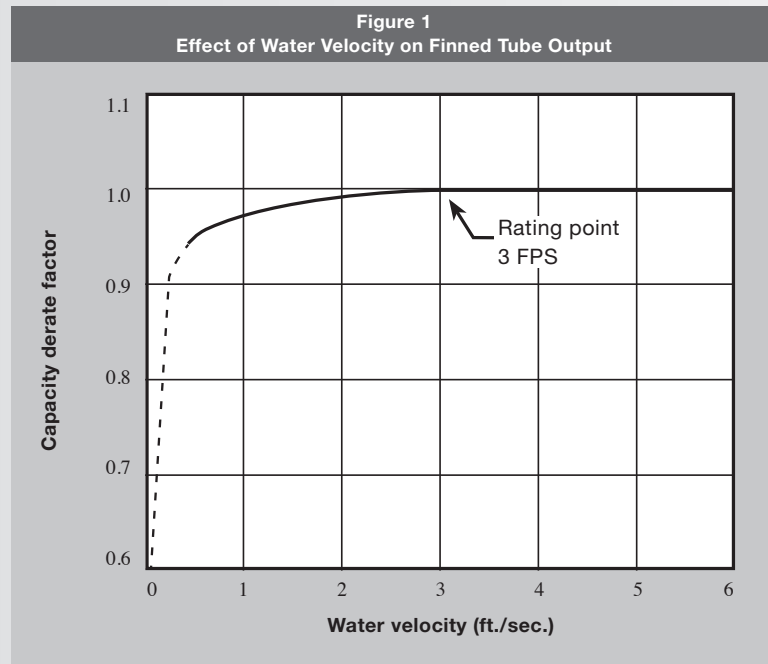

Note:
 ■ ---- below critical velocity

Figure 2
Pipe water capacities and quantities circulated at velocity of *3 feet per second

Pipe Size	Gallons per linear foot	Gallons per minute*	Pounds per hour*
1/2"	.016	2.88	1440
3/4"	.023	4.14	2070
1"	.040	7.20	3600
1-1/4"	.063	11.34	5660
1-1/2"	.102	18.36	9160
2"	.170	30.60	15300
2-1/2"	.275	49.50	24850
3"	.390	70.20	35000

Note:
 ■ *3 feet per second velocity is basis for hot water rating factors shown on this page

$$\text{Velocity ft./sec.} = \frac{\text{lbs./hr.}}{(\text{gal./ft.}) (3600) (8.3)}$$

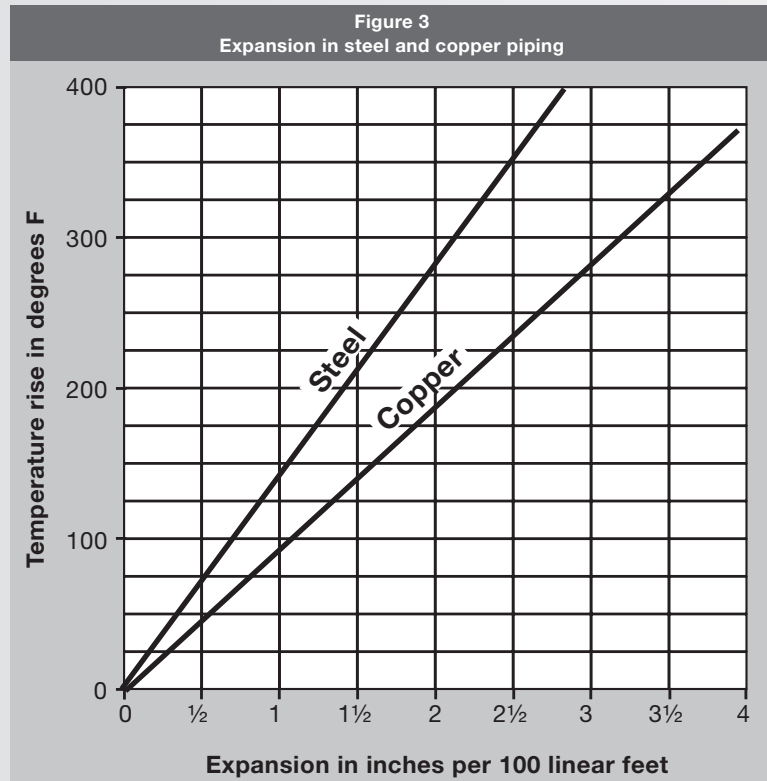

Design data

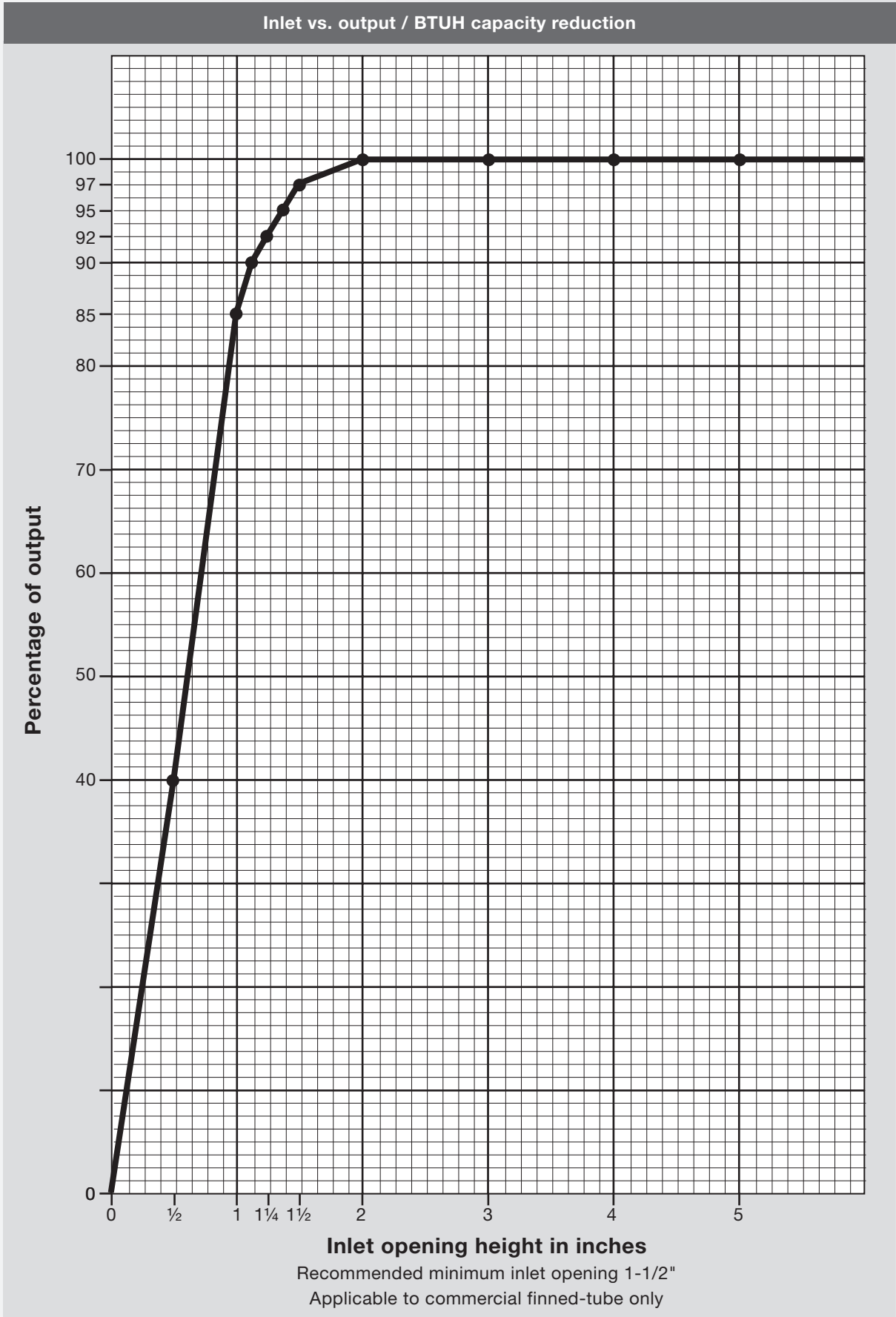

General information

This installation and start-up instructions literature is for Rittling Finned Tube and Enclosures. Designed for year-round heating, your equipment is initially protected under the

Zehnder Rittling standard one-year warranty provided the steps outlined in this manual for initial inspection, installation, periodic maintenance and normal every day operation of the equipment are followed. This manual should be thoroughly reviewed prior to the installation,

start-up or maintenance of the equipment. If any questions arise, please contact your local Zehnder Rittling sales representative or the factory before proceeding any further.

Receiving

Upon delivery, examine the shipment against the bill of lading to make sure all of the equipment has been received and then check each piece carefully for shipping damage. Any damage should be reported to the freight carrier and a claim should be filed with them. Ensure the shipping company makes proper notation of any shortages or damage on all copies of the freight bill. Concealed damage not discovered during unloading must be reported to the shipping company within 15 days of receipt of the shipment. After inspection, return each enclosure to its carton until ready for installation.

All pieces are shipped F.O.B. factory. Therefore, Zehnder Rittling is not responsible for damage during transit. It is the responsibility of the installing contractor to inspect and verify that the pieces shipped were in fact the correct model number, length, height, etc. Any discrepancies should be reported to the local Sales Representative for immediate resolution prior to unpackaging and installation. The factory should be notified of any warranty repairs required in writing before any corrective action is taken. The factory must be fully informed of the expected costs before the work is begun. Zehnder Rittling is not responsible for any repairs or alterations made by the purchaser without Zehnder Rittling's written consent and will not accept any back

charges associated with these repairs or alterations. The return of damaged equipment will not be accepted without written authorization from Zehnder Rittling.

An enclosure that has received a written Return Goods Authorization will be inspected by Zehnder Rittling upon receipt. Any damage, missing parts, reworking or repackaging resulting from prior installation will constitute just cause for Zehnder Rittling to issue partial credit.

Safety considerations

The installation of Rittling Finned Tube, Enclosure and all associated components, parts and accessories which make up the installation, shall be in accordance with the regulations of all authorities having jurisdiction and must conform to all applicable codes. Only trained and qualified service personnel using good judgment and safe practices should install, repair and/or service air conditioning equipment.

Untrained personnel can perform basic maintenance functions such as cleaning the heat transfer surfaces or enclosures. When working on air conditioning equipment, observe precautions in the literature, tags and labels attached to the equipment and all other safety precautions that may apply.

Improper installation, adjustment, alteration, service, maintenance or use, can cause hazardous conditions which may cause serious personal injury and/or property damage. Consult a qualified installer, service agency, or your sales representative for information or assistance.

The equipment must always be properly supported by rigging and lifting equipment. Any temporary supports used during installation or maintenance must be designed to adequately hold the equipment in place until equipment is permanently fastened and set in its final location. All supports must meet applicable local codes and ordinances.

All fastening devices must be designed to mechanically hold the assembly in place without the ability to loosen or break away due to system operation or vibration.

Never use bulky or loose fitting clothing when working on any mechanical equipment. Gloves should always be worn for protection against heat, sharp edges and all other possible hazards. Safety glasses should always be worn, especially when drilling, cutting or working with chemicals.

Never pressurize equipment beyond specified pressures. Always pressure test with an inert fluid such as water or dry nitrogen to avoid possible damage or injury in the event of a leak or component failure during testing.

Always protect adjacent flammable material when welding or soldering. Use a suitable heat shield material to contain sparks or drops of solder. Have a fire extinguisher readily available.

Please follow standard safe practices regarding the handling, installing or servicing of mechanical equipment. Read these instructions thoroughly and follow all warnings or cautions attached to the equipment. Consult local building codes for special installation requirements.

Understand the signal words: danger, warning and caution.

⚠ DANGER

Identifies the most serious hazards which will result in severe personal injury or death.

⚠ WARNING

Signifies hazards that could result in personal injury or death.

⚠ CAUTION

Used to identify unsafe practices, which would result in minor personal injury or product and property damage.

The manufacturer assumes no responsibility for personal injury or property damage resulting from improper or unsafe practices during the handling, installation, service or operation of the equipment. The installation of Finned Tube and Enclosure and all associated components, parts and accessories shall be in accordance with the regulations of all authorities having jurisdiction and must conform to all applicable codes. It is the responsibility of the installing contractor to determine and comply with all applicable codes and regulations.

Unpacking and preparation

All pieces are carefully inspected at the factory throughout the entire fabrication and assembly processes under Zehnder Rittling's stringent quality assurance program. All major components, subassemblies and paint quality are carefully inspected and verified for full compliance with factory standards.

Each enclosure is carefully packaged in a cardboard container and filled with kraft paper padding for shipment to avoid damage during normal handling in the shipment process. It is the sole responsibility of the customer to provide the protection necessary to prevent vandalism and weather deterioration of the equipment. Under no condition should the finned tube and enclosure be left unprotected from the elements. If the equipment is not needed

immediately at the job site, it should be left in its shipping carton and stored in a clean, dry area of the building or in a warehouse. Do not remove any equipment from its shipping package until it is needed for installation. The equipment is NOT suitable for outdoor installations.

After determining the condition of the cardboard container exterior, carefully remove each unit from the container and inspect for hidden damage. Any hidden damage should be recorded and immediately reported to the carrier and a claim should be filed. In the event a claim for shipping damage is filed, the unit, cardboard container, and all packing must be kept for physical inspection by the freight carrier.

Once the equipment is properly positioned on the job site, cover the enclosure with either a shipping carton, vinyl film, or an equivalent protective covering. Cap open ends of piping that are stored on a job site. Take special care to prevent foreign materials from entering the finned tube in areas where painting,

dry walling, or spraying of fireproof material, etc. has not yet been completed as these materials may accumulate on the heat transfer surface. Foreign material that accumulates within the enclosure can limit the heating output of the equipment. Before installing any of the system components, be sure to examine each pipe, fitting and valve, and remove any dirt or foreign material found in or on these components. Some job conditions may require some form of temporary unit covering during construction.

⚠ CAUTION

DO NOT store or install finned tube and enclosures in corrosive environments or in locations subject to temperature or humidity extremes (e.g., attics, garages, rooftops, etc.). Corrosive conditions and high temperature or humidity can significantly reduce system performance, reliability and overall service life.

Handling and installation

While all equipment is designed for durability and fabricated with heavy gauge materials and may present a robust appearance, great care must be taken to assure that no undue force is applied to the enclosure or other delicate components such as finned tube during handling. Gloves should be worn when handling finished, painted

enclosures and should never be set down on unclean, hard surfaces. Failure to follow these instructions may lead to scratching or gouging of the finished surface.

Anchoring the equipment in place is accomplished by using the mounting points provided, and positioning the unit on a LEVEL plane.

After mounting the finned tube, it is then ready for the water connection. The proper line size and water temperature should be available to the unit.

On finned tube with steam heating, the proper line sizing and routing should be verified. The maximum steam pressure should never exceed 15 psig. The drain piping and steam trap, supplied by others, should be sized and routed to allow for proper condensate flow.

All installations should be made in compliance with all governing codes and ordinances. Compliance with all codes is the responsibility of the installing contractor.

Installation Pedestal

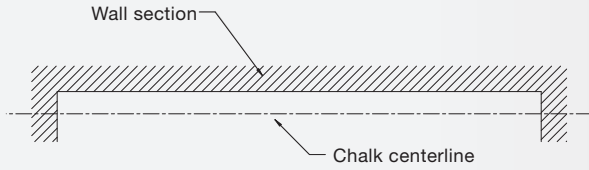

Figure P-1

1. The floor should be continuous and level under each pedestal. Snap a chalk line on the floor along the centerline of the pedestals. The pedestal centerline should be 4" from the wall for one row pedestals, and 6-1/2" from the wall for two row pedestals. (Figure P-1)

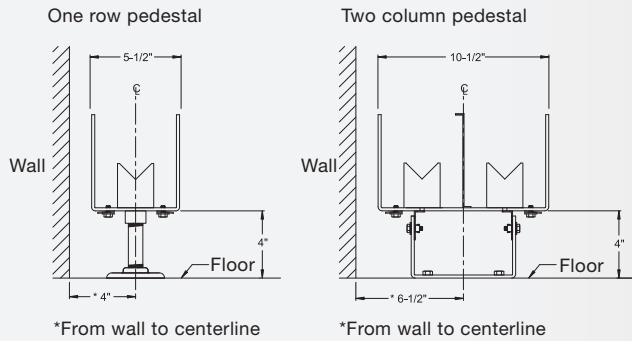

Figure P-2

2. Place the pedestals along the chalk line evenly. The pedestal should be installed a maximum of 3'-0" apart on center. Secure the pedestal using a fastener suitable for floor construction.

Adjust the pedestals to the desired height. The minimum recommended height of the pedestal from the floor is 4". (Figure P-2)

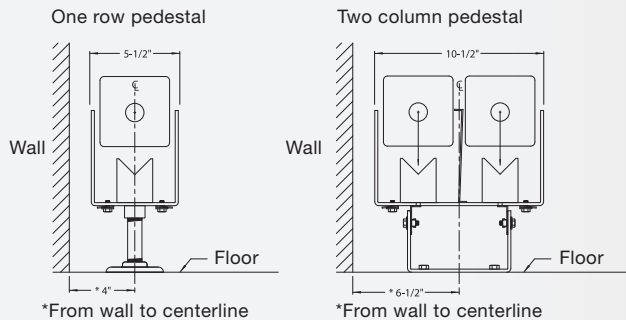

Figure P-3

3. Place the heating element on the pedestal. Before connecting the piping to the system, be sure to purge the system to insure against heating element blockage. Care must also be taken to prevent debris from entering the system when making the piping connections. (Figure P-3)

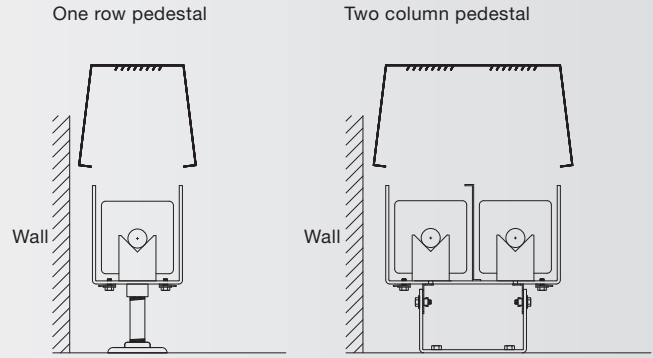

Figure P-4

4. Install the enclosure over the pedestal bracket. (Figure P-4)

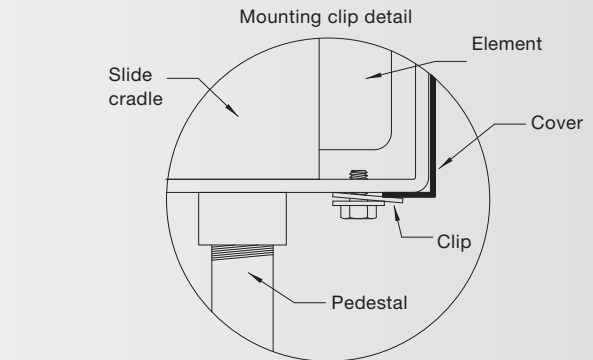
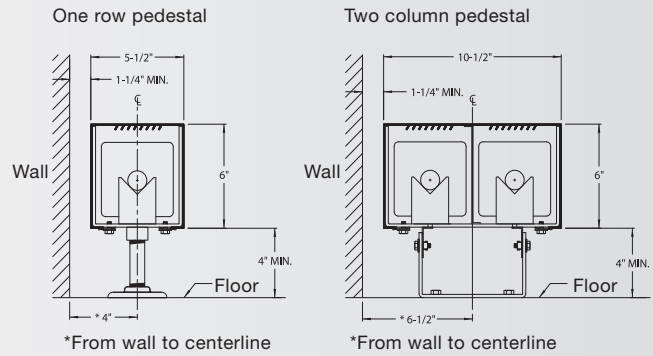

Figure P-5

5. Once the cover is in place, secure the bottom of the enclosure by tightening the mounting clips on the bottom of the bracket. (Figure P-5)

Installation

Snap mounting channel, open inlet or backplate

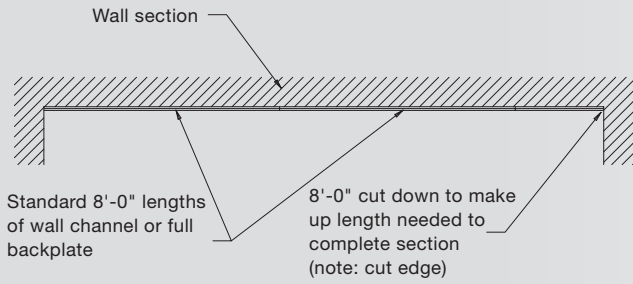
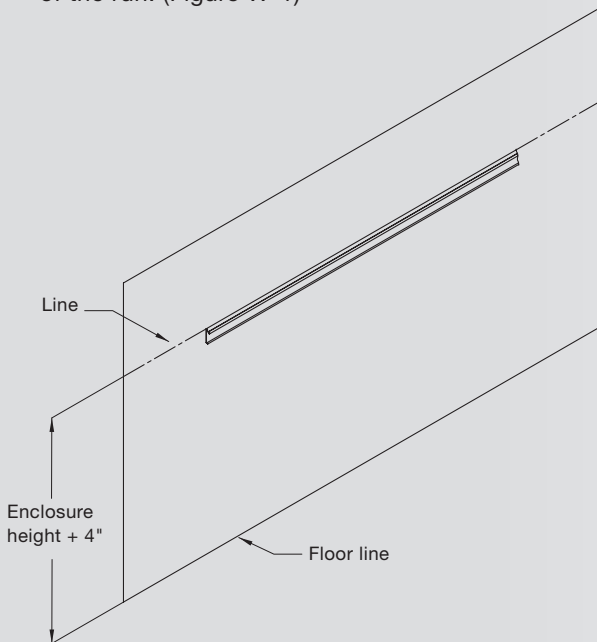

Figure W-1

- 1a. Determine the distance needed for wall enclosure application. The snap mounting channel or snap full height backplate should be installed on the entire wall surface where the enclosure and accessories will be installed.
- 1b. Cut the snap mounting channel or snap full height backplate to the desired length. The channel and backplate are furnished in lengths of 4'-0" or 8'-0". Combine multiple lengths if needed. When joining two pieces, make sure that the cut end is at the end of the run. (Figure W-1)



2. Find and mark the mounting height on the wall. (The standard mounting height is equal to the enclosure height plus 4".)

The snap mounting channel or full height backplate should be lined up flush with the marked mounting height. Attach the snap mounting channel or full height backplate using fasteners suitable for wall construction. (Figure W-2)

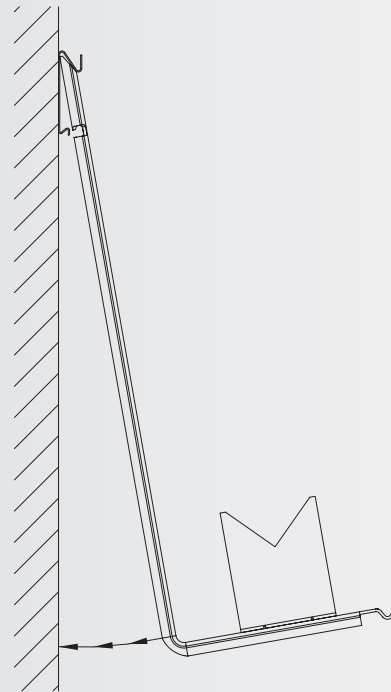

Figure W-3

3. Slip the snap expansion bracket into the snap mounting channel or full height backplate, and snap into place. (Figure W-3)

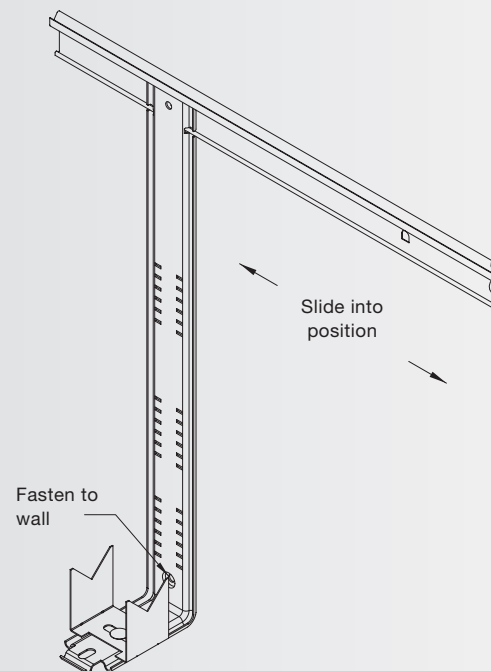

Figure W-4

4. Slide the snap expansion bracket into place and fasten the bottom of the bracket. (The snap expansion brackets should be installed approximately 36" apart.) The snap expansion bracket is installed with a fastener using the recessed hole near the bottom of the bracket. (Figure W-4)

Installation

Wall channel or full backplate

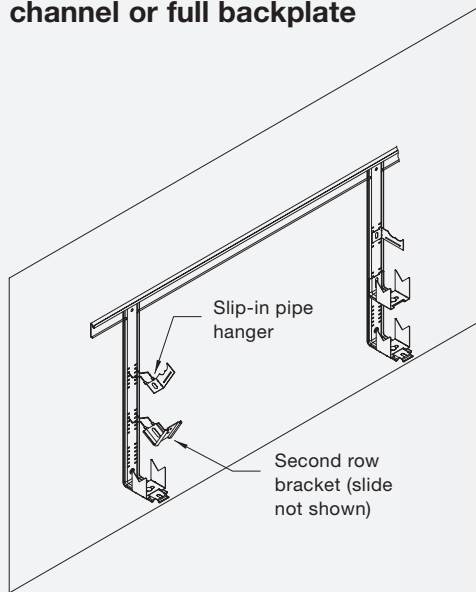

Figure W-5

5. Install any additional mounting brackets to the snap expansion bracket by slipping them into the slots provided on the snap expansion bracket. (Not all mounting brackets are available on all units.) (Figure W-5)

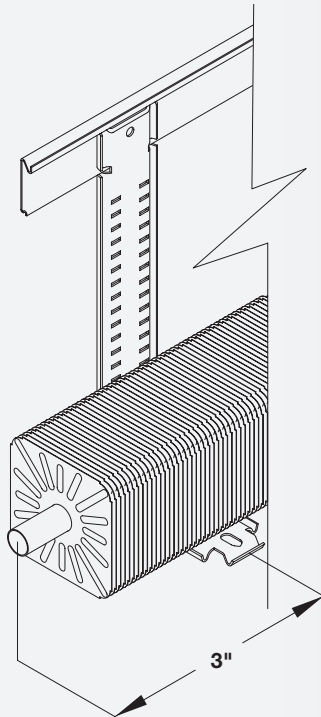

Figure W-6

6. Install the heating element on the slide cradles located on the brackets. (The end of the heating element should be installed at least 3" from the snap expansion bracket center.)

If installing additional rows of heating element or return piping, always install the bottom-most element first and work upward. (Figure W-6)

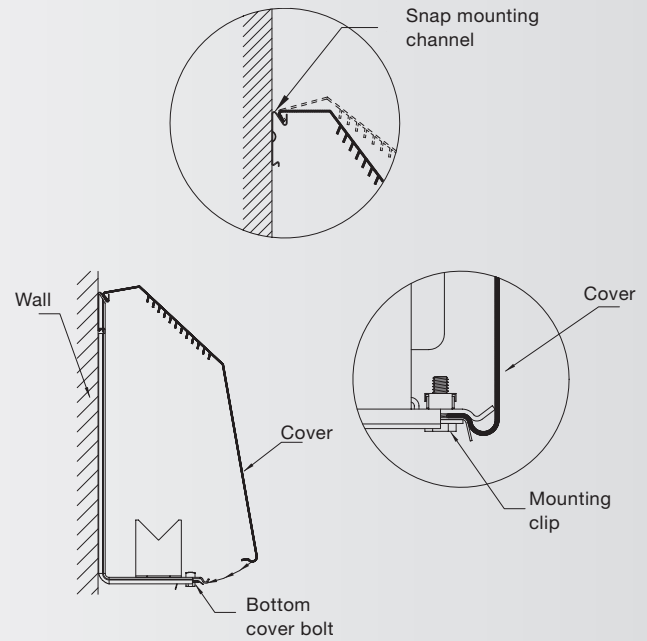

Figure W-7

7. Install the cover as shown. (Figure W-7) Tighten the mounting clip bottom bolt to secure the cover in place.
8. Install accessories between the wall and wall channel at

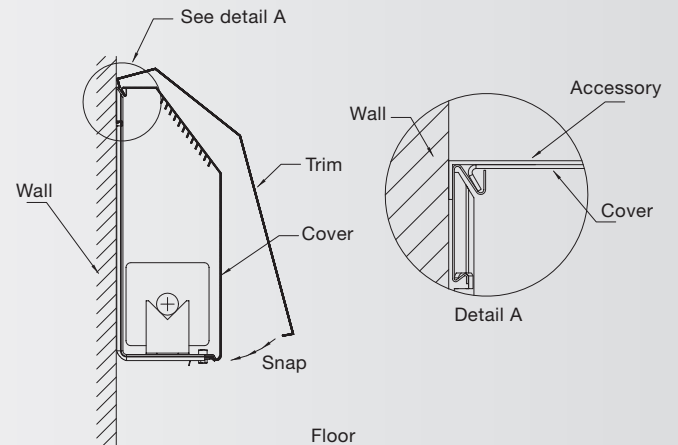

Figure W-8

- the top and around the cover at the bottom. (Figure W-8)

Installation

Snap mounting channel or full backplate, closed to the floor or wall

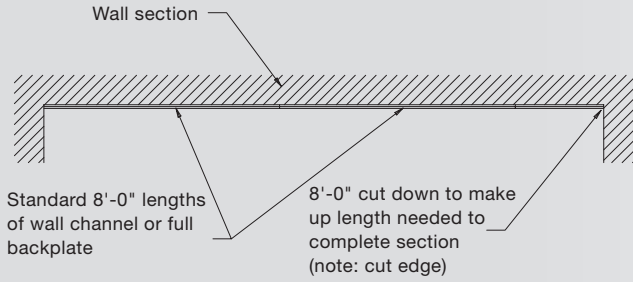

Figure VH-1

- 1a. Determine the distance needed for wall enclosure application. The snap mounting channel or snap full height backplate should be installed on the entire wall surface where the enclosure and accessories will be installed.
- 1b. Cut the snap mounting channel or snap full height backplate to the desired length. The channel and backplate are furnished in lengths of 4'-0" or 8'-0". Combine multiple lengths if needed. When joining two pieces, make sure that the cut end is at the end of the run. (Figure VH-1)

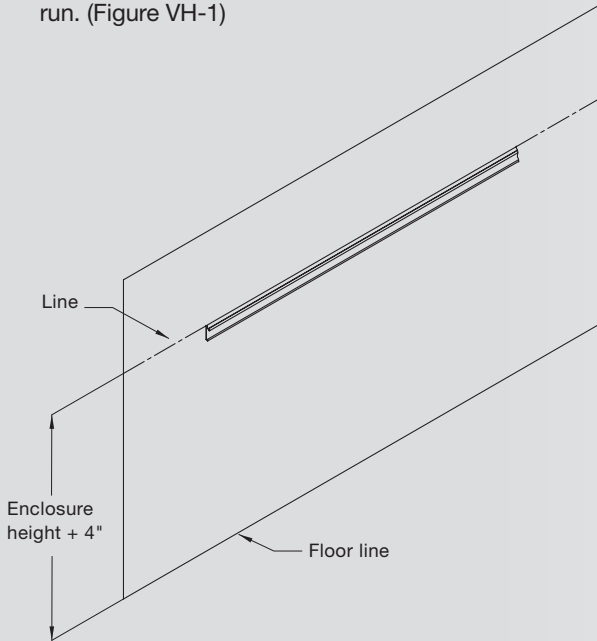

Figure VH-2

2. Find and mark the mounting height on the wall. (The standard mounting height is equal to the enclosure height plus 4" for HL models and just the enclosure height for VL models.)

The snap mounting channel or full height backplate should be lines up flush with the marked mounting height. Attach the snap mounting channel or full height backplate using fasteners suitable for wall construction.

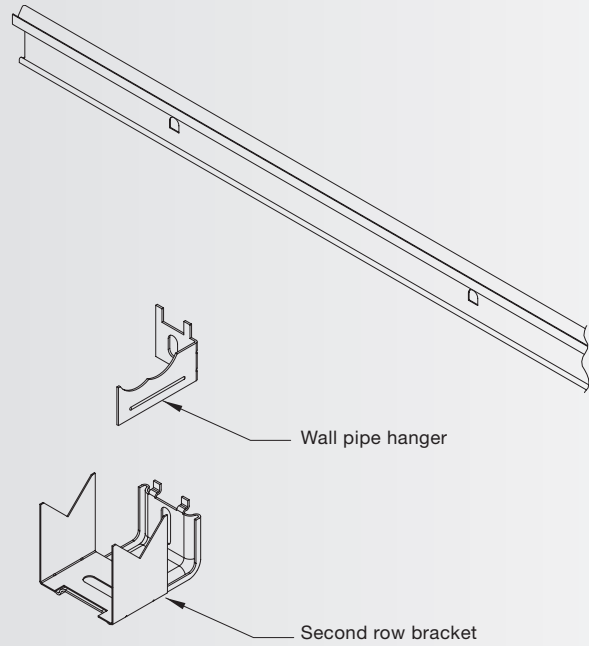

Figure VH-3

3. On enclosed units, the second row brackets and wall pipe hangers will be mounted directly to the wall. (the brackets and pipe hangers should be installed approximately 36" apart.) Install the second row brackets and wall pipe hangers to the wall using fasteners suitable for wall construction. (Figure VH-3)

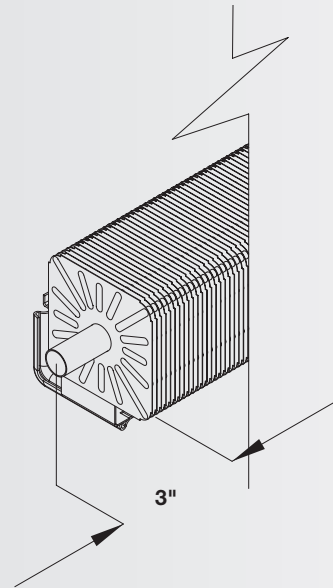

Figure VH-4

4. Install the heating element on the slide cradles located on the second row bracket. (The end of the heating element should be installed at least 3" from the second row bracket.)

If installing additional rows of heating element or return piping, always install the bottom-most element first and work upward. (Figure VH-4)

Installation

Floor mounted

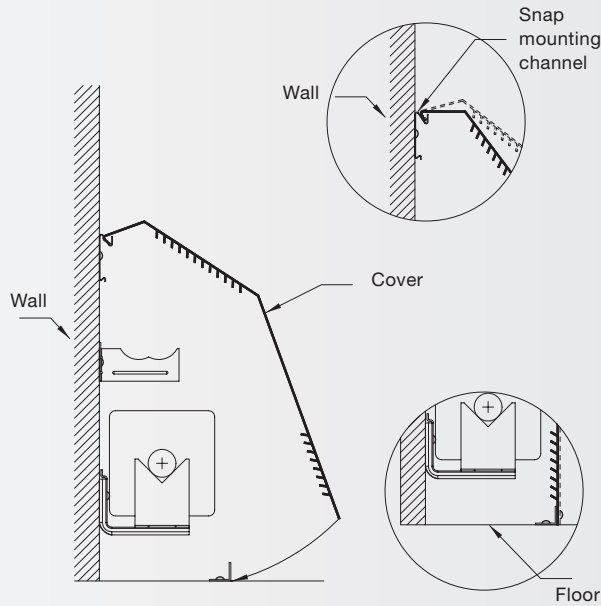

Figure V-5

1. Install floor angle to floor using suitable fasteners. For 3-15/16" deep enclosure, the floor angle must be mounted 3-7/8" from the base at the wall. For 5-3/8" deep enclosure, the floor angle must be mounted 5-5/16" away from the base of the wall. (Figure V-5)

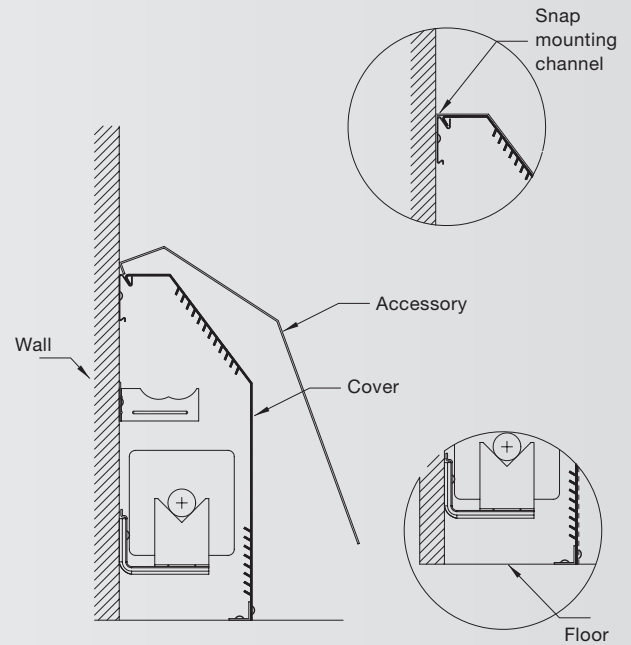

Figure V-6

2. Install accessories between the wall and wall channel at the top and around the cover at the bottom. Secure cover to floor mounted angle using suitable fasteners. (Figure V-6)

Bottom inlet enclosure

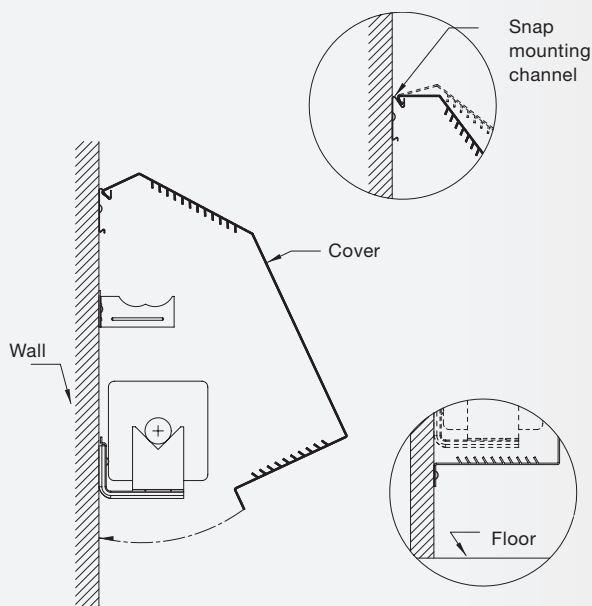

Figure H-5

1. Install the cover as shown. Secure cover to wall using suitable fasteners. (Figure H-5)

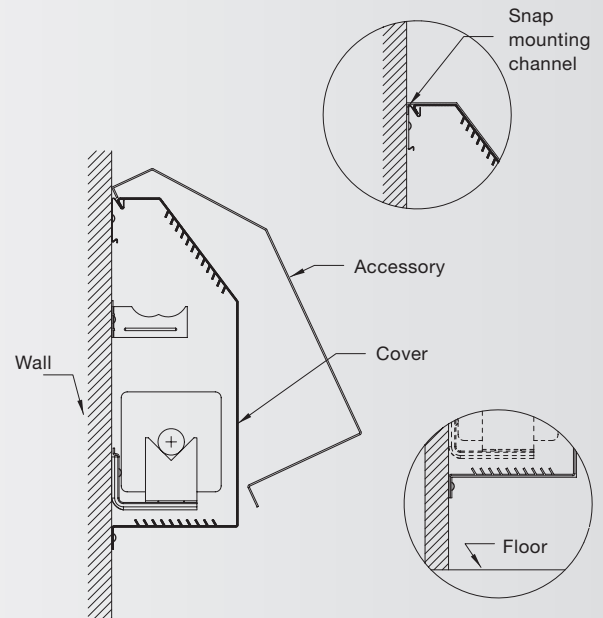

Figure H-6

2. Install accessories between the wall and wall channel at the top and around the cover at the bottom. Secure accessory to wall using suitable fasteners. (Figure H-6)

Installation

Offset strip or full backplate

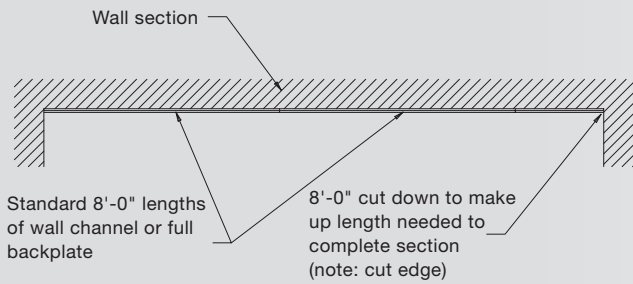

Figure S-1

- 1a. Determine the distance needed for wall enclosure application. The offset channel or full height backplate should be installed on the entire wall surface where the enclosure and accessories will be installed.
- 1b. Cut the offset channel of full height backplate to the length needed. The channel and backplate are furnished in lengths of 4'-0" or 8'-0". Combine multiple lengths if needed to complete the distance. When joining two pieces, make sure that the cut end is at the end of the run. (Figure S-1)

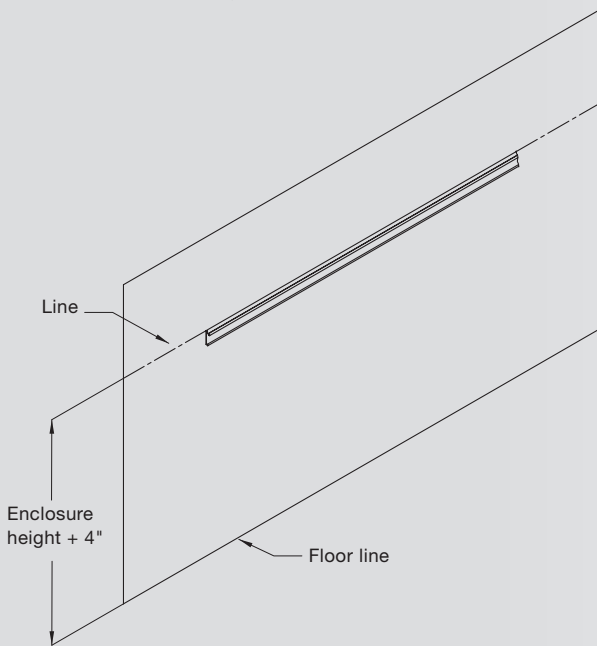

Figure S-2

2. Find and mark the mounting height on the wall. (The standard mounting height is equal to the enclosure height plus 4".)

The offset channel or offset full height backplate should be lined up flush with the marked mounting height. Attach the offset channel or offset full height backplate using fasteners suitable for wall construction. (Figure S-2)

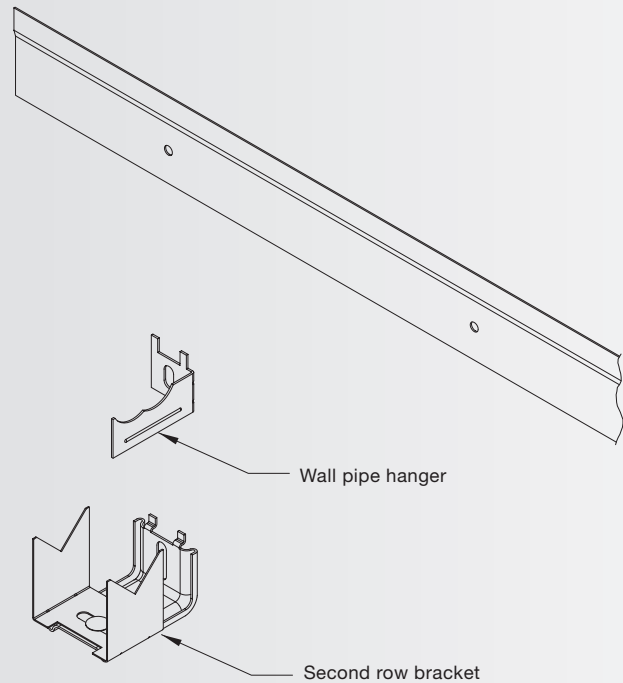

Figure S-3

3. On security units the second row brackets and wall pipe hangers will be mounted directly to the wall. (The brackets and pipe hangers should be installed approximately 36" apart.) Install the second row brackets and wall pipe hangers to the wall using fasteners suitable for wall construction. (Figure S-3)

Installation

Offset strip or full backplate

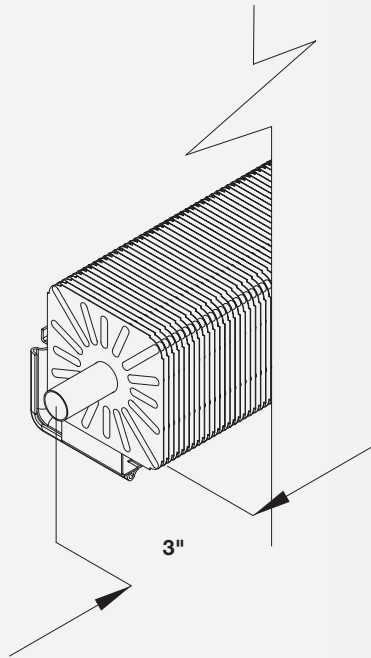

Figure S-4

4. Install the heating element on the slide cradles located on the second row bracket. (The end of the heating element should be installed at least 3" from the second row bracket.)

If installing additional rows of heating element or return piping, always install the bottom-most element first and work upward. (Figure S-4)

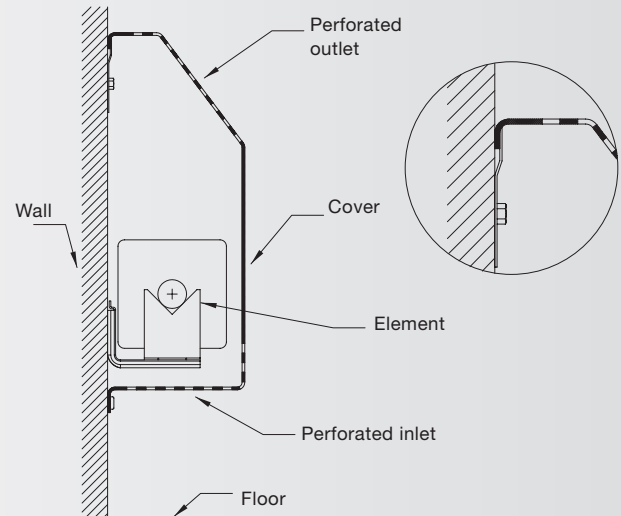

Figure S-5

- 5a. Place the cover over the element and the offset strip and push the cover until it locks into the strip. (Figure S-5)
- 5b. The trims and accessories will be attached in the same manner, overlapping the cover.

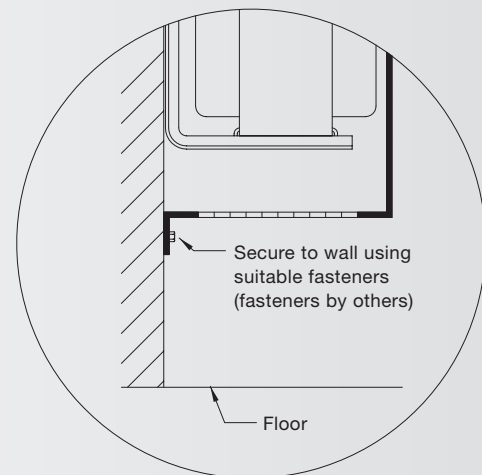
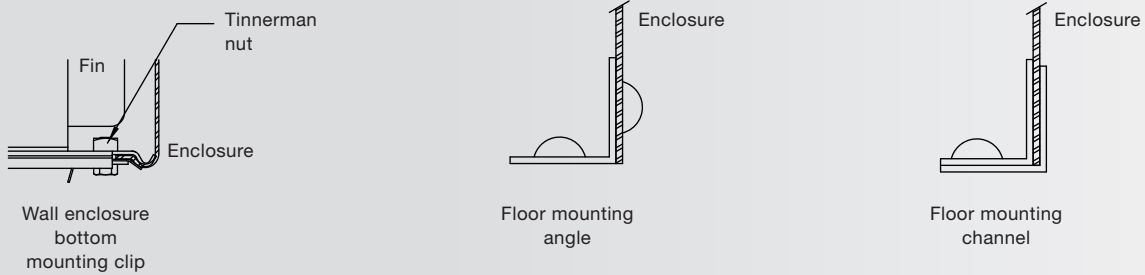
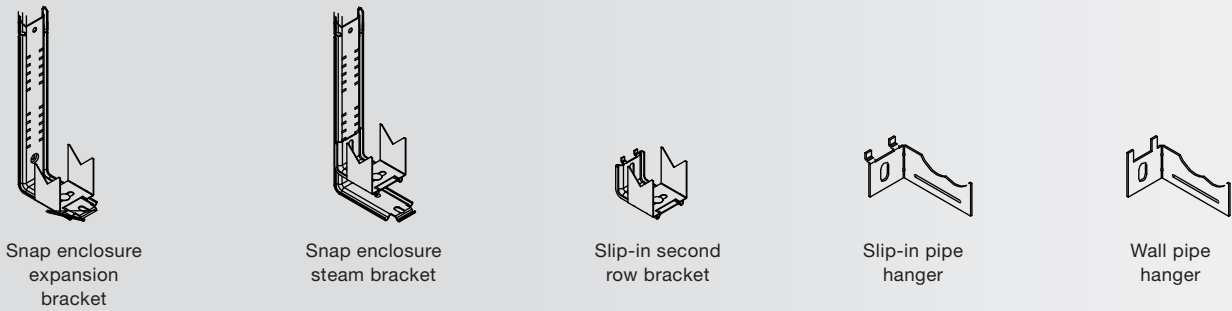
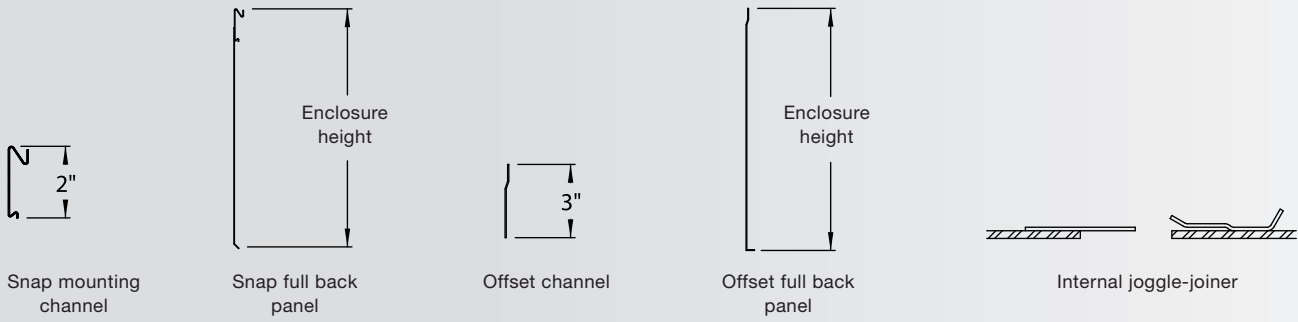

Figure S-6

6. Once in place, the cover, trim and accessories should all be secured to the wall. Use a fastener suitable for wall construction. (Figure S-6)

Standard hardware, wall mounting



Standard hardware, pedestal mounting

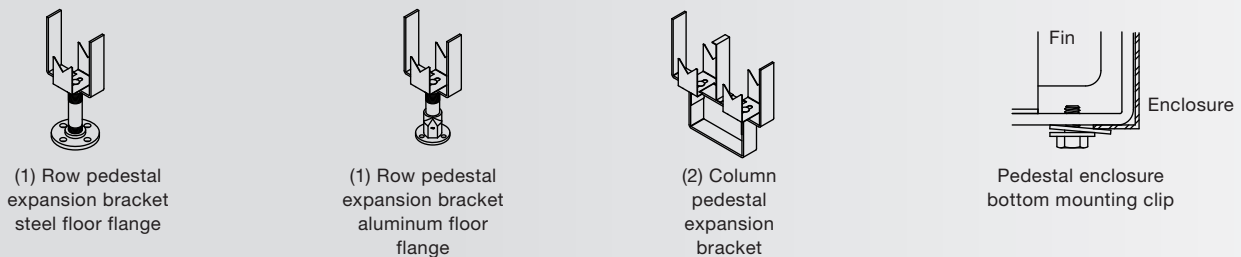

Hot water connections

Submittals and product literature detailing finned tube operation and connection should be thoroughly reviewed before beginning the connection of the heating medium to the unit.

All finned tube connections are to be made with a sweat or solder joint.

After the connections are completed, the system should be tested for leaks. Since some components are not designed to hold pressure with a gas, hydronic systems should be tested with water. Test pressure must not exceed 250 psig. Pressure testing should be completed prior to sheet rocking, finished floors, painting, caulking, etc.

⚠ CAUTION

All finned tube must be protected from freezing after initial filling with water. Even if the system is drained, finned tube may still hold enough water to cause damage when exposed to temperatures below freezing.

In the event that leaking is occurring somewhere other than a field installed joint, the Zehnder Rittling Sales Representative must be notified before any repairs are attempted. All leaks should be repaired before proceeding with the installation.

Enclosure touch-up and repainting

Enclosure will be furnished with an epoxy powder coated paint finish. Small scratches in the finish may be repaired with touch-up spray paint available from the factory.

⚠ CAUTION

Proper safety procedures should be followed regarding ventilation and personal safety equipment when using spray paint. Follow the manufacturer's directions for the products being used.

To repaint the factory powder coat finish, prepare the surface by lightly sanding with #280 grit sand paper or #000 or #0000 fine steel wool. The surface may also be wiped with a liquid surface etch cleaning product. These items should be available at most paint product stores. It should be noted that the more care taken during the process, the more effective it will be.

After this preparation is finished, the factory finish should provide excellent adhesion for a variety of air dried top coats. Enamel will give a more durable, higher gloss finish, while latex will not adhere as well and will give a dull, softer finish. Top coats involving an exothermic chemical process between two components such as epoxies and urethanes should be avoided.

All standard colors including primer can be painted over. If the installing contractor chooses not to paint over the primer color, the factory cannot match primer color on future orders, potentially causing color match issues in the field.

Factory touch-up spray paint may require a number of light coats to isolate the factory finish from the quick drying touch-up paint.

Start-up general

Before beginning any start-up, the start-up personnel should take the time to familiarize themselves with the finned tube and enclosure to fully understand how it should operate properly under normal conditions. All personnel should have a good working knowledge of general start-up procedures.

The building must be completely finished before attempting to start-up equipment, including doors, windows and insulation. All internal doors and walls should be in place. In some cases, the internal decorations and furniture may influence overall system performance. The entire building should be as complete as possible before beginning any system balancing.

The initial step is to visually inspect all of the equipment and piping. Ensure that all systems are properly installed and supported and that all construction debris or foreign objects have been removed from the equipment.

Heating system

Prior to the water system start-up and balancing, the hot water system should be thoroughly flushed to clean out dirt and debris which may have accumulated in the piping during construction.

Strainers should be installed in the piping mains to prevent any foreign material from entering the finned tube during normal operation.

During system filling, air venting from the unit is accomplished by the use of a manual air vent, provided by others.

⚠ CAUTION

The air vents provided are not intended to replace the main system air vents and may not release air trapped in other parts of the system. Inspect the entire system for potential air traps and independently vent those areas as required. In addition, some systems may require repeated venting over time to fully eliminate air in the system.

Water system balancing

A complete knowledge of the hydronic system, including its components and controls, is essential to proper water system balancing and should only be completed by a qualified expert. The system must be complete, and all components must be in operating condition before beginning the water system balancing procedures.

Each hydronic system has different operating conditions depending on the devices and controls installed for the particular application. The actual balancing technique may vary from one system to another.

After the proper system operation is established, the appropriate operating conditions such as water temperatures, flow rates and pressure drops should be recorded for future reference.

Before and during water system balancing, conditions may exist due to incorrect system pressures which may result in noticeable water noise or undesired valve operation. After the entire system is balanced, these conditions will not exist on properly designed systems. If any of these conditions persist, recheck the system for air that may not have been properly vented during start-up.

Water treatment

Proper water treatment is a specialized industry and therefore it is recommended to consult an expert in this field to analyze the water for compliance with the water quality parameters listed below and to specify the appropriate water treatment program. The expert may recommend rust inhibitors, scaling preventative, antimicrobial growth agents or algae preventatives. Anti-freeze solutions, glycols, may also be used to lower the freezing point.

All Zehnder Rittling finned tube is constructed of copper or steel tubes. It is the end user's responsibility to ensure that any of the water delivery components are compatible with the treated water.

Failure to provide proper water quality will void the warranty.

Water content	Required concentration
Sulphate	< 200 ppm
pH	7.0 – 8.5
Chlorides	< 200 ppm
Nitrate	< 100 ppm
Iron	< 4.5 mg/L
Ammonia	< 2.0 mg/L
Manganese	< 0.1 mg/L
Dissolved solids	< 1000 mg/L
Calcium carbonate hardness	300 – 500 ppm
Calcium carbonate alkalinity	300 – 500 ppm
Particulate quantity	< 10 ppm
Particulate size	800 micron max

Finned tube maintenance

Regular maintenance of the fin-tube radiation units will help keep the unit running at optimum capacity. A regularly scheduled inspection and maintenance program should be implemented and followed.

Cover

Use a soft non-abrasive cloth with a standard household cleaner. Under no circumstances should an abrasive cleaner be used.

Heating Element

The heating element should be cleaned at least once every year. More frequent cleanings should occur if the heating element appears to have a build-up of contaminants. Remove any dirt by brushing or vacuuming the

heating element. High-pressure air may be blown through the heating element to dislodge any built-up contaminants.

For a deeper cleaning, spray the finned surface with a neutral cleaning solution and rinse thoroughly. Zehnder Rittling recommends using neutral pH cleaners. Avoid the use of strong acids and strong base cleaners. Thus, cleaners with pH range from 5 to 11 are suitable for coil cleaning. This range includes such over-the-counter cleaners as Simple Green® All Purpose Cleaner, or HVAC coil cleaners like Nu-Calgon Evap Pow'r®. Strong acidic cleaners (pH of 5 or less) that contain hydrochloric, sulfuric, nitric or acetic acid are not recommended for use on copper-tube, aluminum fin elements. Presence of these acids will result in rapid corrosion of the metals. Strong alkali (base) cleaners (pH of 11 or more) containing sodium, potassium or ammonium hydroxide

are not recommended as they will aggressively corrode aluminum tubes and fins. Strong ammonium hydroxide cleaners will also cause stress corrosion cracking of copper tubes. Zehnder Rittling recommends completely rinsing all cleaners from the coil, including cleaners identified as no-rinse cleaners. Residual cleaners may decompose over time producing low molecular weight, organic acids that lead to formicary corrosion.

Replacement parts

Factory replacement parts should be used wherever possible to maintain unit performance and its normal operating characteristics.

Replacement parts may be purchased through the local Zehnder Rittling Sales Representative.

Contact the local Sales Representative or factory before attempting any unit modifications. Any modifications not authorized by the factory could result in personnel injury, damage to the equipment and will void the manufacturer's warranty.

When ordering parts, the following information should be supplied to ensure proper part identification:

- Complete unit model number
- Complete part description including any identifying numbers on the part

On warranty replacements, it is often necessary to return the faulty component to receive credit. Contact the local Sales Representative who will get authorization from the factory including an RGA (Returned Goods Authorization) to be used when sending components back for inspection. Any returned components sent back to the factory without the proper RGA attached will cancel any outstanding credit.

Equipment start-up checklist

Receiving and inspection

- Pieces received undamaged
- Pieces received complete as ordered

Finned Tube and Enclosure

- Mounted level and square
- Proper hot water line sizes to finned tube

- All services to finned tube in code compliance
- Finned tube and enclosure protected from dirt and foreign matter

Heating connections

- Connect field piping to finned tube
- Pressure test all piping for leaks
- Install drain lines and traps, as required
- Insulate all piping, as required

Unit start-up

- General visual inspection and system inspection
- Close all finned tube isolation valves
- Flush water systems
- After system has been flushed, ensure all isolation valves are open

Warranty

Zehnder Rittling guarantees its products to be free from defects in material and workmanship for a period of one year from date of shipment from our factory.

Should there be any defects in the good(s), the purchaser should promptly notify Zehnder Rittling. Upon receipt of written consent from Zehnder Rittling, the purchaser shall return the defective good(s) to the factory for inspection with freight prepaid. If inspection shows the goods to be defective, Zehnder Rittling will at its discretion repair or replace the said item(s).

Defects arising from damage due to shipment, improper installation, negligence or misuse by others are not covered by this warranty.

This warranty is extended only to the original purchaser from Zehnder Rittling.

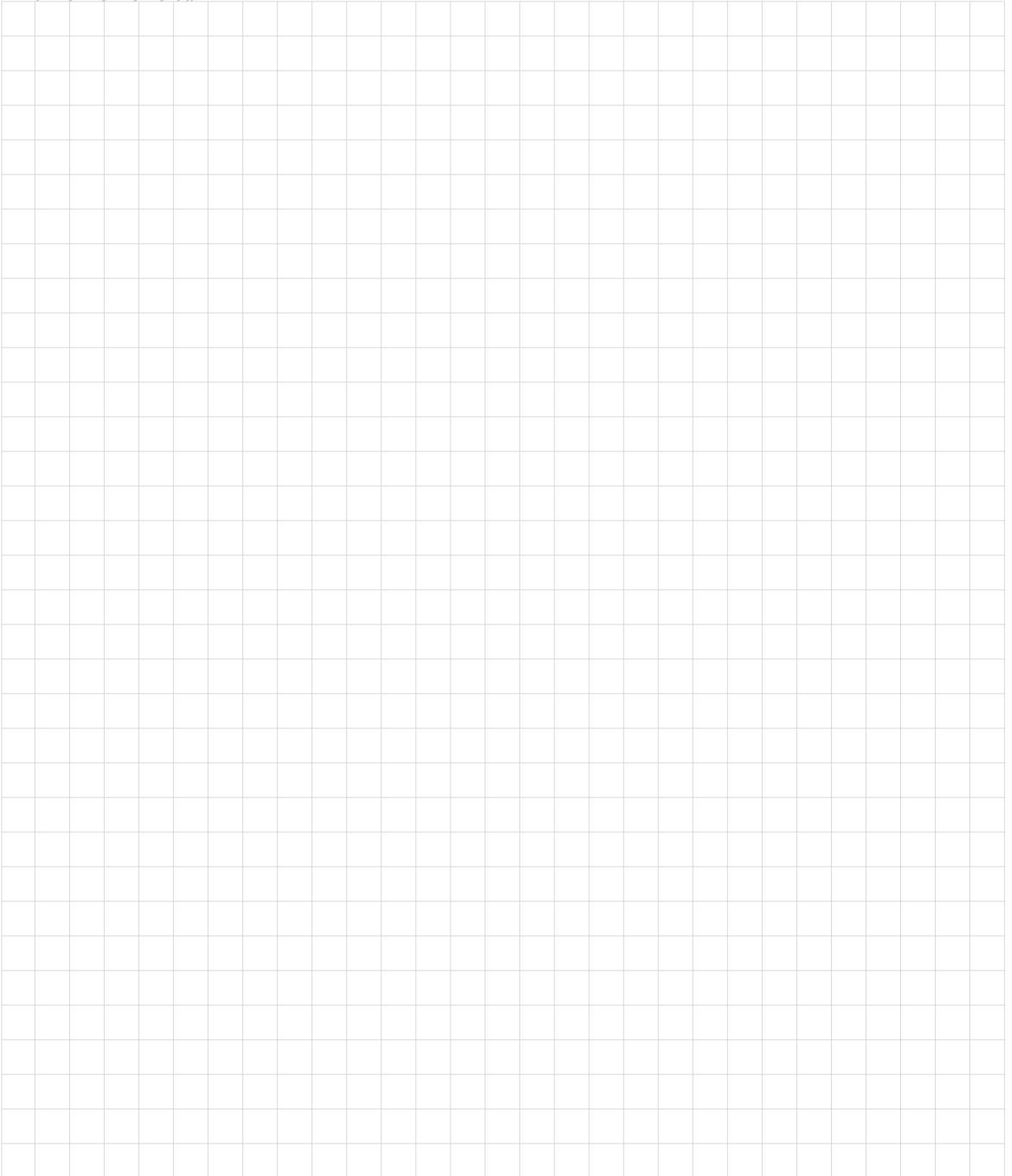

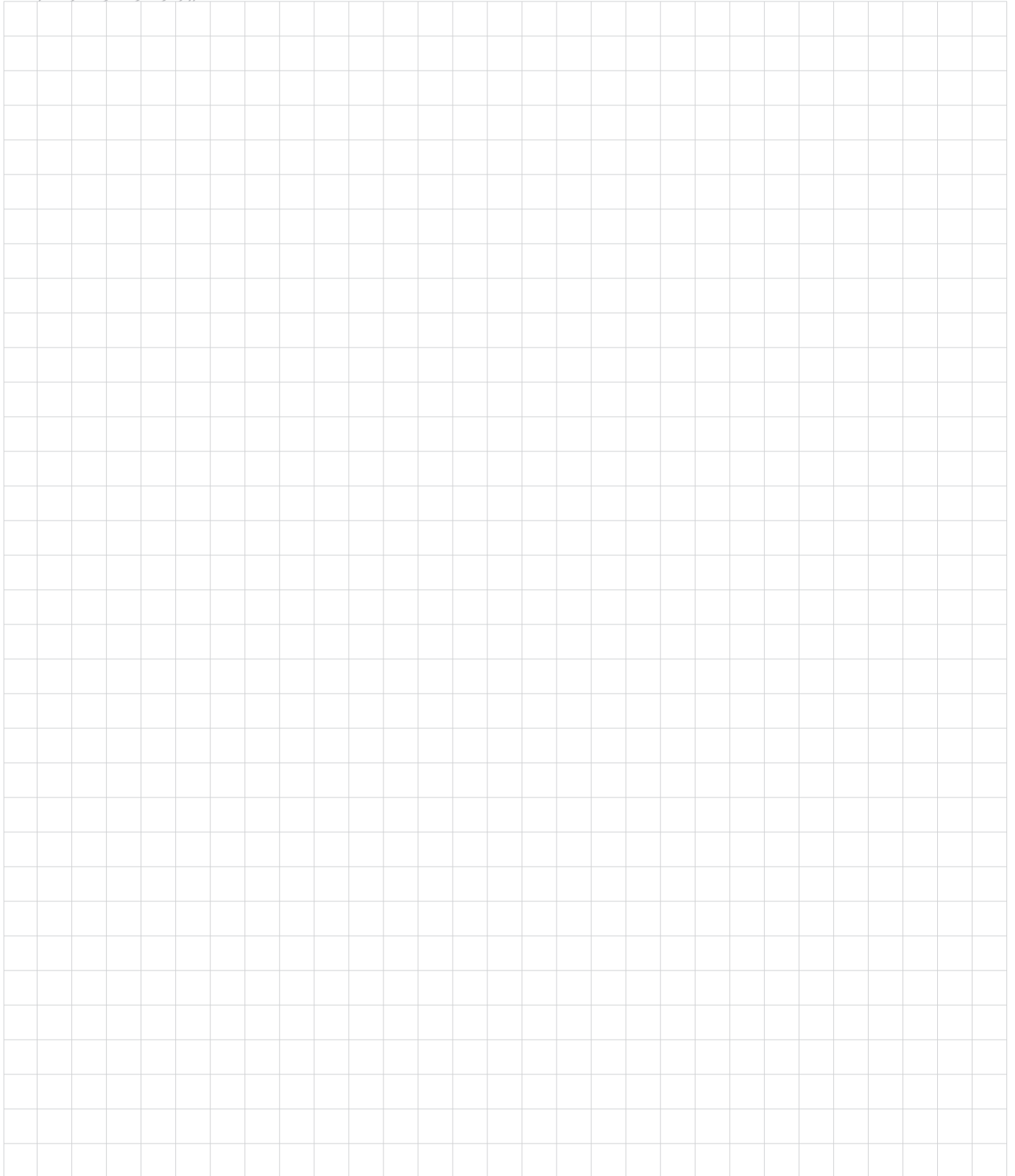



N° 209940

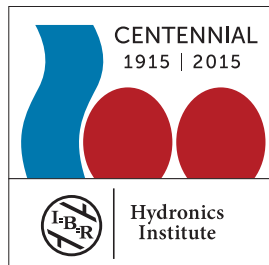

Zehnder Rittling · 100 Rittling Boulevard · Buffalo, NY USA 14220
T 844-934-6337 (844-ZEHNDER) · F 716-827-6523
sales@zehnder-rittling.com · www.zehnder-rittling.com

zehnder
Rittling