

# Linear Radiant Ceiling Panels

## Catalog

Heating

Cooling

Fresh air

Clean air



# Zehnder – everything you need to create a comfortable, healthy and energy-efficient indoor climate

Heating, cooling, fresh and clean air: at Zehnder, you will find everything you need to create a comfortable, healthy and energy-efficient indoor climate. Zehnder's wide and clearly structured portfolio can offer the right product for any project, be it private, public or commercial, new build or refurbishment. And where service is also concerned, you'll find that Zehnder is "always around you."

## Heating

At Zehnder, **Heating** doesn't just come in the form of designer radiators. We offer solutions in all shapes and sizes, from radiant ceiling panels to heat pumps with integrated ventilation devices.

- Designer radiators
- Compact energy station with integrated heat pump
- Heating and cooling ceiling systems
- Comfortable indoor ventilation with heat recovery



## Cooling

Zehnder also offers sophisticated solutions for indoor **Cooling**. These range from cooling ceiling systems to comfortable indoor ventilation with a supply of pre-cooled fresh air.

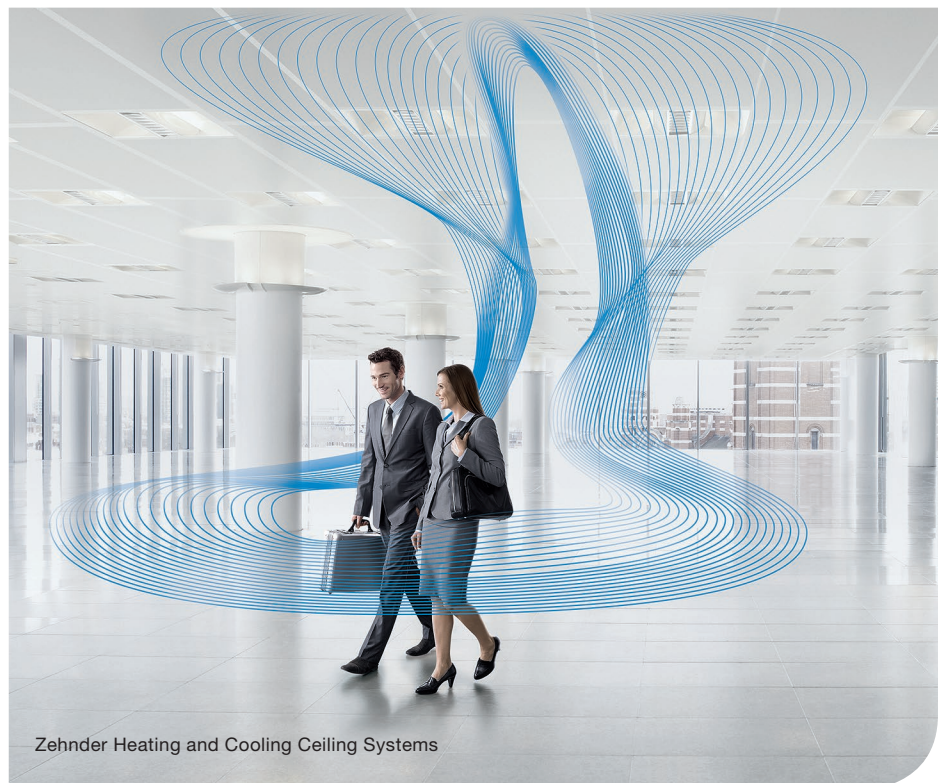

## Fresh air

Fresh air – a product range with a long tradition at Zehnder. Zehnder Comfosystems provides products and solutions for comfortable indoor ventilation with heat recovery for houses and apartments, for new builds and for renovation projects.

- Comfortable indoor ventilation
- Compact energy station with integrated ventilation device



## Clean air

Zehnder Clean air Solutions provide Clean air in buildings particularly prone to dust. In residential applications, the comfortable indoor ventilation provided by Zehnder Comfosystems filters external pollutants out of the air.

- Comfortable indoor ventilation with integrated fresh-air filter
- Compact energy station with integrated fresh-air filter
- Systems for clean air



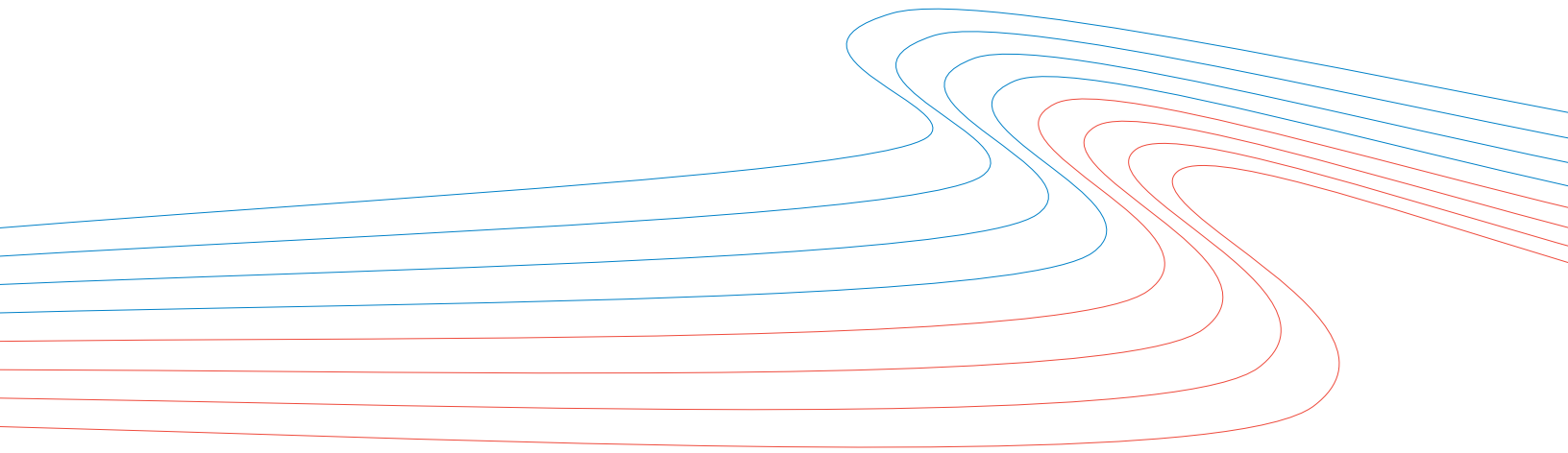

## A trusted name in hydronic heating

Since 1946, when Charles Rittling founded Rittling Heat Transfer, Inc., the company has led the industry in quality, responsiveness, and innovation. With patented and proven heating and cooling products, and custom-build engineering with CAD design capabilities, Zehnder Rittling is a single source supplier for the full variety of hydronic solutions.

Based in Western New York, Zehnder Rittling employs a highly skilled and diverse work force. Certified ISO 9001:2008, the company prides itself on the skills of its employees, the design talent of its engineers, and the cost saving innovations of management.

Zehnder Rittling is a “green” company that helps protect our environment through conservation, recycling, and disposal — efforts that have been recognized in the award of 1997’s New York State Governor’s Award for Pollution Prevention.

Whether you’re an architect, engineer, or contractor, Zehnder Rittling hydronic heating and cooling products are built to keep your job moving smoothly. Exacting quality control and on-time delivery systems make it easier to coordinate the many different components and aspects of large-scale construction projects. Our on-staff engineering department and CAD systems result in lower operating costs, reduced pricing, and custom-build capabilities that rival any in the industry.

<b>Application</b>	<b>4</b>		
<b>Theory of radiant heating</b>	<b>6</b>	<b>Ceiling height de-rating</b>	<b>13</b>
<b>Design considerations</b>	<b>8</b>	<b>Suspension details</b>	<b>14</b>
<b>Selection procedure</b>	<b>10</b>	<b>Piping components</b>	<b>15</b>
<b>Performance</b>	<b>10</b>	<b>Mechanical specifications</b>	<b>16</b>
<b>Dimensions and data</b>	<b>12</b>	<b>Warranty</b>	<b>17</b>

**Zehnder Rittling...  
Custom-building  
innovative hydronic  
systems for commerce,  
industry and  
institutions since 1946**

Zehnder Rittling long ago coined the phrase “Reinventing Finned Tube” to describe its commitment to design innovation... and its unlimited custom engineering capability. For decades, Zehnder Rittling’s constantly-expanding inventory... and proven ability to control costs without compromising the highest quality standards in manufacturing...have made the name synonymous with image, performance, reliability, price, delivery and service.

Zehnder Rittling Radiant Ceiling Panel offers the best of both worlds... advanced hydronic technology and the sleek, unobtrusive appearance of the ceiling design. Form, function, comfort and energy conservation are all engineered in an environmentally sound way to provide clean, efficient and reliable heating for a variety of applications.

For the architects of the future, Zehnder Rittling will continue to advance Radiant Ceiling Panel technology in still more new directions...and develop ever more efficient, cost-effective hydronic heat transfer systems.

Seventy years of quality, innovation and service... and we're just getting warmed up.



## Application

Radiant heating is widely regarded as the most comfortable, healthiest, and most natural heating process available. People are warmed in the same way as they are warmed from the sun on a cool day. Floor drafts, cold spots, and dry air are eliminated. Low humidity levels, dust, air contaminants (mold, fungi, bacterium and viruses), all problems associated with forced-air heating and cooling, are greatly reduced and often completely eliminated. Other advantages include lower installed costs, lower energy usage, reduced maintenance, quiet operation, and more uniform heating and cooling of the space.

Our Linear Radiant Ceiling Panels were developed in response to the needs expressed by the architects, designers, and contractors that have been solving hydronic heating and cooling problems with Zehnder Rittling products for many years. Radiant panel technology is a proven technology that has been in widespread use in Europe for over 100 years and with the increasing concerns over air quality in Canada and United States, is quickly growing in the North American marketplace.

Linear ceiling panels are made of extruded aluminum and are available in 6" width combinations and in lengths compatible with perimeter planning modules or the materials handling limitations of each particular project up to a maximum of 16 feet.

These highly efficient panels supply the heating requirements for a typical building while taking up as little as 12 to 24 inches of the perimeter ceiling plane. This innovative product affords not only the human comfort and efficiency long associated with radiant systems, but also unrestricted design freedom, outstanding aesthetics, space utility, flexibility, and economic feasibility.

The elimination of unsightly wall and floor-mounted units, by concealing the heating source in the ceiling, creates an unobstructed perimeter wall that allows unlimited creativity and flexibility in the interior design.

The Zehnder Rittling Linear Radiant Panels provide a narrow border around the ceiling perimeter that contrasts or compliments the most creative ceiling. They are effortlessly incorporated into a perimeter soffit drop or continuous window pocket.

The uniform, draftless heating and cooling provided by the system allows the total interior to be utilized, even at those locations where an occupant is seated adjacent to large areas of glass.

Re-allocation of space and occupant changes are easily accommodated when the open-office concept of floor-to-ceiling partitions are involved. Since the radiant panels can be furnished in lengths compatible with perimeter planning modules, layout changes can be easily implemented. Simply adjusting terminal connections and adding thermostatic controls accomplishes this. Sound transmission is a non-issue since the Zehnder Rittling radiant ceiling panels have a higher STC rating than most acoustical ceiling tiles.

It has long been recognized that radiant energy transfer is the most effective known method of transferring energy. Millions of square feet of radiant ceilings have been installed in various types of buildings, most notably office buildings, apartments, retail stores, hospitals, banks, churches, airports and schools. Today's high fuel costs make the benefits of radiant systems economically advantageous for much broader applications, especially for office buildings.



## Application

Some of the more popular applications include:

### Hospitals

Hospitals have been the most frequent users of radiant ceiling panel systems for heating and cooling patient rooms because these systems:

- Require no mechanical equipment or other operational systems that can create, collect and spread bacteria and viruses in the conditioned space.
- Provide a draft free, thermal stable environment.
- Do not take up any space in the room.

Individual room control is obtained by adjusting the water flow through the panels. The air supply is often 100% outdoor air with minimum air quantities

delivered to the room for ventilation and bathroom exhaust. Piping systems may be two, three or four pipe designs. Water control valves are located in the corridor outside the patient rooms so they can be adjusted or serviced without entering the room.

### Office buildings

Radiant ceiling panels are applied for heating or as a total heating and cooling system. A single zone central air supply system provides ventilation, dehumidification and any additional cooling required. Panel systems readily accommodate changes in partitioning. Complete flexibility can be achieved through modular installations.

### Schools

Ceiling panel systems in schools are similar to those used for office buildings with the additional advantage of eliminating noise from mechanical equipment which

may interfere with instructional activities. For heating applications, a radiant ceiling panel system may be used with any type of ventilation system.

If the school is cooled with a central air system and uses ceiling panels for perimeter heating, a single zone piping system may be used to control panel heat output. The room thermostat can modulate air temperature of volume delivered to the room.

The Zehnder Rittling Linear Radiant Ceiling Panels epitomize both functional and economical efficiency in heating and/or cooling today's buildings.

## Theory of radiant heating

Radiant energy is transmitted by electromagnetic waves that travel in straight lines, can be reflected, and heat solid objects but do not heat the air through which the energy is transmitted. All objects with a surface temperature above absolute zero transmit and absorb these waves in varying degrees depending on the body surface temperature. Every microscopic crevice of the surface absorbs and reradiates the heat to an adjacent, colder object. When examined under a microscope, a concrete surface shows a large number of crevices while polished steel or similar polished surface show no such crevices. Thus, a rough surface transmits radiant energy more efficiently than a polished surface. Unlike convection, which is actually a current of warmed air, radiant heat does not rise. The floor is kept as warm as all other absorbing objects in the room including the ceiling. The Zehnder Rittling radiant ceiling panels, when placed around the perimeter of the space, create a uniform, draft-free thermal barrier.

The ability of a surface to emit or absorb radiant energy is known as emissivity. It is expressed as a ratio (decimal) of the radiating ability of a given material to that of a black body. A black body emits radiation at the maximum possible rate at any given temperature, and has an emissivity of 1.00. Figure 1. shows the emissivity of various products. For practical purposes, it can be assumed that a good emitter is a good absorber.

Material	Emissivity Ratio
Aluminum - Commercial Sheet	0.09
Aluminum - Highly Oxidized	0.20
Asbestos	0.93
Brick	0.93
Brass - Polished	0.03
Carbon	0.81
Copper	0.07
Galvanizing	0.23
Glass	0.94
Gypsum	0.90
Marble	0.93
Paint - White Lacquer	0.80
Paint - White enamel	0.91
Paint - Black Lacquer	0.80
Paint - Oil	0.96
Paint - Aluminum	0.39
Paint - Varnish	0.93
Paper	0.92
Plaster	0.91
Porcelain	0.92
Rubber - Soft	0.86
Rubber - Hard	0.95
Steel	0.12
Wood - Oak, Planed	0.90

Figure 1.

A surface with a high emissivity factor would radiate more energy than one with a lower value. For instance, copper, with an emissivity of 0.07 would have a low emissivity, but if painted with an enamel paint having an emissivity of 0.91, would have a much higher emissivity.

Radiant heat is transmitted by the sun and is the best and most well known example of radiant heat transmission. The effect of sun radiation is best experienced when the body is exposed to the sun's rays on a cool but sunny day. Some of these rays striking the body come directly from the sun while other rays strike surrounding objects, where they are increased in wavelength and reradiated to the body as low temperature radiation, thus producing a comfortable feeling of warmth. If the sun suddenly disappears behind a cloud, there is an instant

sensation of cold, although the air temperature does not vary at all during this brief time.

Perceptions of comfort, temperature, and thermal acceptability are related to activity, the transfer of body heat from the skin to the environment, and the resulting physiological adjustments and body temperature. Heat transfer is affected by the ambient air temperature, thermal radiation, air movement, humidity, and clothing worn. Comfort is associated with a neutral thermal sensation during which the human body regulates its internal temperature with minimal physiological effort for the activity concerned. It is sometimes thought that a radiant heat system is desirable only for certain buildings and only

## Theory of radiant heating

in some climates. However, anywhere people live, the three factors of heat loss (radiation, convection, and evaporation) must be considered. It is as important to provide the correct conditions in very cold climates as it is in warm climates. Maintaining the correct comfort conditions by heating with low temperature radiation is possible for even the most severe weather conditions.

Panel heating and cooling systems' main function is to provide a comfortable environment, which is accomplished by controlling surface temperature and minimizing excessive air motion within the space. Thermal comfort, as defined by ASHRAE Standard 55-2010, is "that condition of mind which expresses satisfaction with the thermal environment." An acceptable environment is defined as one in which at least 80% of the occupants perceive a thermal sensation between "slightly cool" and "slightly warm". When the surface temperature of the outside walls, particularly those with large amounts of glass, begins to deviate excessively from the ambient air temperature of the space, it is increasingly difficult for convective systems to counteract the discomfort resulting from cold or hot walls. Heating and cooling panels neutralize these deficiencies and minimize excessive radiation losses from the body. When the average unheated surface temperature falls below the mean panel temperature, the panels

radiate energy into the room. This radiated energy does not immediately warm the air but actually warms the objects in the space including the walls, glass, floor, furniture, and people, which in turn, warm the air.

Radiant panel performance is directly related to the building in which it is located, differing from most heat transfer equipment where performance can be specifically measured, independent of its surroundings. Various outside sources have conducted research on panel performance where heat transfer between the radiant panel and the other room surfaces is well established. The primary heat gains and losses are from the wall, floor, and ceiling surfaces. This data should only be used in consultation with manufacturers experienced in this field.

Fortunately, most building surfaces have high emissivity factors and therefore actively absorb and reradiate energy from the panels. This is significant because all surfaces within the room tend to assume an equilibrium temperature resulting an even thermal comfort condition within the space. In much the same way that lighting is placed in the ceiling so that all objects can be "seen" without obstruction, the radiant panels are placed in the ceiling for the same maximum effect. An active radiant panel transmits energy that is absorbed and reradiated by all the room objects, thereby warming all surfaces. Warm ceiling panels are effective for winter heating because they warm the floor and glass surfaces by direct transfer of radiant energy. The surface temperature of properly constructed and insulated floors will be 3 - 4 °F (1 - 2 °C) above the ambient air temperature and actually provide a source of reradiated heat. In fact, where down drafts from

cold walls or glazing present design challenges in respect to occupant comfort, radiant panels provide a solution. The ceiling panels warm the wall or window surfaces by direct transfer of radiant energy, significantly increasing the surface temperature of each. Testing has shown that inside single-glass surface temperatures of 10 - 15°F (5 - 8°C) above normally observed glass surface temperatures are realized, reducing air velocities to less than 50 fpm (0.25 m/s). As a result, downdrafts are minimized to the point where no discomfort is felt. Installation with ceiling heights of 50 ft (15 m) and single glass from floor to ceiling provide satisfactory results.

## Design considerations

### System design

The design of a radiant ceiling perimeter system follows the usual design for re-circulating water systems which incorporate remote terminals for space heating.

Standard controls adjust the supply of heated water to the panels on demand from the room or zone thermostat. The aluminum panels respond almost instantaneously and the space quickly receives the desired heat. The piping and controls are similar to those used with conventional perimeter hot water systems but all pipes are in the ceiling plenum where they are readily accessible.

As the radiant panels raise the mean radiant temperature in the space they produce greater thermal comfort at ambient temperatures lower than those required with convective systems. An inside dry bulb design temperature 3 to 4°F below that normally used with convective systems is recommended.

Room loads should be calculated in a normal manner using the procedures set forth in the ASHRAE guide.

### General design

The application, design and installation of Zehnder Rittling Radiant Ceiling Panel Systems have certain requirements and techniques that should be adhered to:

- As with any hydronic system, close attention should be paid to the piping system design. Piping should be designed to assure that water of the proper temperature and in sufficient quantity will be available to every grid or coil at all times.
- The cooling coils and air distribution should be carefully designed to ensure proper performance. Most problems occur when air equipment is not capable of delivering air quantities at the specified rates.
- Individual ceiling panel coils may be connected for parallel flow using headers or for series flow.
- Design piping configurations such that the highest temperature water is always supplied closest to the perimeter wall.
- Attention must be given to avoid noise from entrained air, high velocity or high pressure drop devices or from pump or pipe vibrations. Water velocities should be high enough to prevent air from accumulating and causing air binding. Air venting devices should be manual rather than automatic and, where possible, should not be located over the ceiling of occupied spaces.
- Piping systems must be designed to adequately accept thermal expansion. Forces from pipe expansion must not be transmitted to ceiling panels. Attention must be given to the thermal expansion of the ceiling panels.
- Interconnecting piping between panels should be of soft drawn copper and sufficiently looped to provide access to the panel from below if necessary. All piping should be tested to at least three times working pressure, but not less than 150 psi.
- Radiant ceiling panels should be located adjacent to the outside wall and in as close proximity as possible to the areas of maximum load. The panel area within three feet of the outside wall should have a heating capacity equal to or greater than 50% of the wall transmission load.
- Systems designed to pass return air through the ceiling panels are not recommended since much of the panel heat transfer will be lost to the return air system.
- Sufficient space above the ceiling must be allowed for installing and connecting the radiant ceiling panel piping.
- Room thermostat should be located on a side wall where it can "see" the outside wall and not the warm ceiling. The normal thermostat cover reacts to the warm ceiling panel and the radiant effect of the ceiling on the cover tends to alter the control point so that the thermostat controls two to three degrees lower when the outdoor temperature is at a minimum and the ceiling temperature is at a maximum.
- When the panel area for cooling is greater than the area for heating, two panel arrangement may be used. One panel, or grid of panels, is supplied with hot or chilled water year round. The other panel, or grid of panels, is supplied with chilled water only during the cooling season.

## Design considerations

- To prevent condensation on the cooling panels, the panel water supply temperature should be maintained at least 1°F above the dew point temperature of the air in contact with the panel.
- Selection of summer design room dew point temperature below 50°F generally does not prove to be economical.
- Because air quantity requirements are generally small when compared to a conventional system, it is not advisable to use an air volume control in any part of a radiant panel cooling system.
- Proper design of a variable volume system for use with a radiant panel cooling system requires that the latent load be based on the minimum air volume capacity. This is possible only if the room thermostat is staged with the radiant cooling valve port and the variable volume control operator. However, the system cannot be properly balanced if the exhaust air system is not controlled in conjunction with the supply air variations.
- Control zones are similar to those used in conventional systems. A multi-story commercial building will typically have nine zones: four corner zones, four exterior zones and one interior zone. Since interior zones require cooling year round, radiant panel cooling can be used in the interior zone in conjunction with a heat pump cycle. This can reduce total operating cost particularly in an all electrical building.
- Radiant heating and cooling panel systems usually allow utilization of constant air volume and constant ventilation air temperature. However, during freezing weather the owner may wish to set the ventilation air temperature higher. In this situation, it is recommended that the ventilation air temperature be maintained at least 3 to 5°F below the space design temperature since ventilation air should handle the latent loads and not the sensible loads.
- During the winter, radiant panel heating of perimeter zones can be scheduled according to the outdoor temperature and/or solar sensors. Modulating control valves will function properly if water temperature is increased as outdoor temperatures drop. Temperature control of the interior zone and the radiant panel cooling system should not be a function of outdoor weather.
- As with all radiant ceiling panel systems, the supply air dew point should be reduced during extremely cold weather in accordance with the type of glazing installed to prevent condensation on window surfaces.

## Selection procedure

The design of an extruded radiant panel system should follow all the usual design considerations for a closed water system. There are a number of basic design criteria that need to be obtained in order to properly design the system. They include the following:

- Determine the room design temperature.
- Determine the heat loss for the room.
- Determine the design hot water entering and leaving temperatures. Mean water temperature is determined by subtracting half of the water temperature difference from entering water temperature.
- Determine the panel layout (i.e. continuous perimeter strip, between columns only, etc.)
- Determine the capacity of the radiant panels.
- Calculate the area, width, and length of the panels.
- Calculate the water flow rate.
- Determine piping arrangement and water pressure drop per circuit.

The following standard formulas can be used to determine the necessary design criteria:

### Heat Loss:

$$\frac{\text{Total BTU/hr}}{\text{Lineal ft. of panel}} = \text{BTU/hr required per lineal ft.}$$

### Panel Width:

$$\frac{\text{Required BTU/hr per lineal ft.}}{\text{Panel performance BTU/hr}} = \text{Panel width in ft.}$$

### Flow Rate in GPM:

$$\text{GPM} = \frac{\text{Total BTU/hr}}{*500 \times \text{Water temperature drop (°F)}} * \text{constant}$$

## Heating performance

- 70 °F air temperature
- Heating performance values in BTU/hr lf of panel

	Panel Width						BTU/hr lf <sup>2</sup>
	6" 1 Tube	12" 2 Tubes	18" 3 Tubes	24" 4 Tubes	30" 5 Tubes	36" 6 Tubes	
120	53	77	109	163	195	223	68
125	61	93	127	186	225	257	76
130	71	106	148	213	257	290	85
135	80	120	165	237	286	325	97
140	86	134	187	264	315	361	107
145	96	148	204	288	345	393	115
150	103	162	225	313	376	427	124
155	112	178	246	339	405	462	135
160	121	190	262	362	436	498	146
165	128	206	282	389	465	532	156
170	136	219	303	414	496	565	164
175	146	233	321	437	527	598	176
180	154	245	339	463	555	632	187
185	161	261	359	488	587	668	198
190	172	274	380	512	615	702	209
195	179	289	397	538	646	737	219
200	188	303	416	562	676	770	230
205	195	316	436	588	704	804	241
210	203	329	455	613	734	838	253
215	212	345	473	637	764	874	264
220	220	359	491	653	793	908	275

## Cooling performance

- \*(Room temperature) - (Mean water temperature)
- Due to actual conditions, stated performance values can vary plus or minus 3%

Δ T* (F°)	Room interior	Perimeter panels exterior wall conditions					
		0% Glass full sun	25% Glass full sun	50% Glass full sun	75% Glass full sun	100% Glass full sun	100% Glass full shade
		BTU / hr lf <sup>2</sup>					
10	18	21	28	34	38	40	21
11	20	23	31	36	41	42	23
12	21	25	32	37	42	43	25
13	22	26	33	39	43	45	26
14	25	28	35	41	45	47	28
15	27	31	37	43	47	49	31
16	28	32	39	45	48	51	32
17	30	34	41	46	50	52	34
18	32	36	42	48	52	54	36
19	34	38	44	50	54	56	38
20	35	40	46	52	55	57	40
21	37	42	48	53	57	59	42
22	38	44	49	55	59	60	44
23	40	45	51	57	61	62	45
24	42	47	53	59	62	64	47
25	44	49	55	60	64	65	49
26	46	51	56	62	66	67	51
27	48	53	58	63	67	69	53
28	49	54	60	65	69	71	54
29	51	56	62	67	71	72	56
30	52	58	64	69	73	74	58

# Dimensions and data

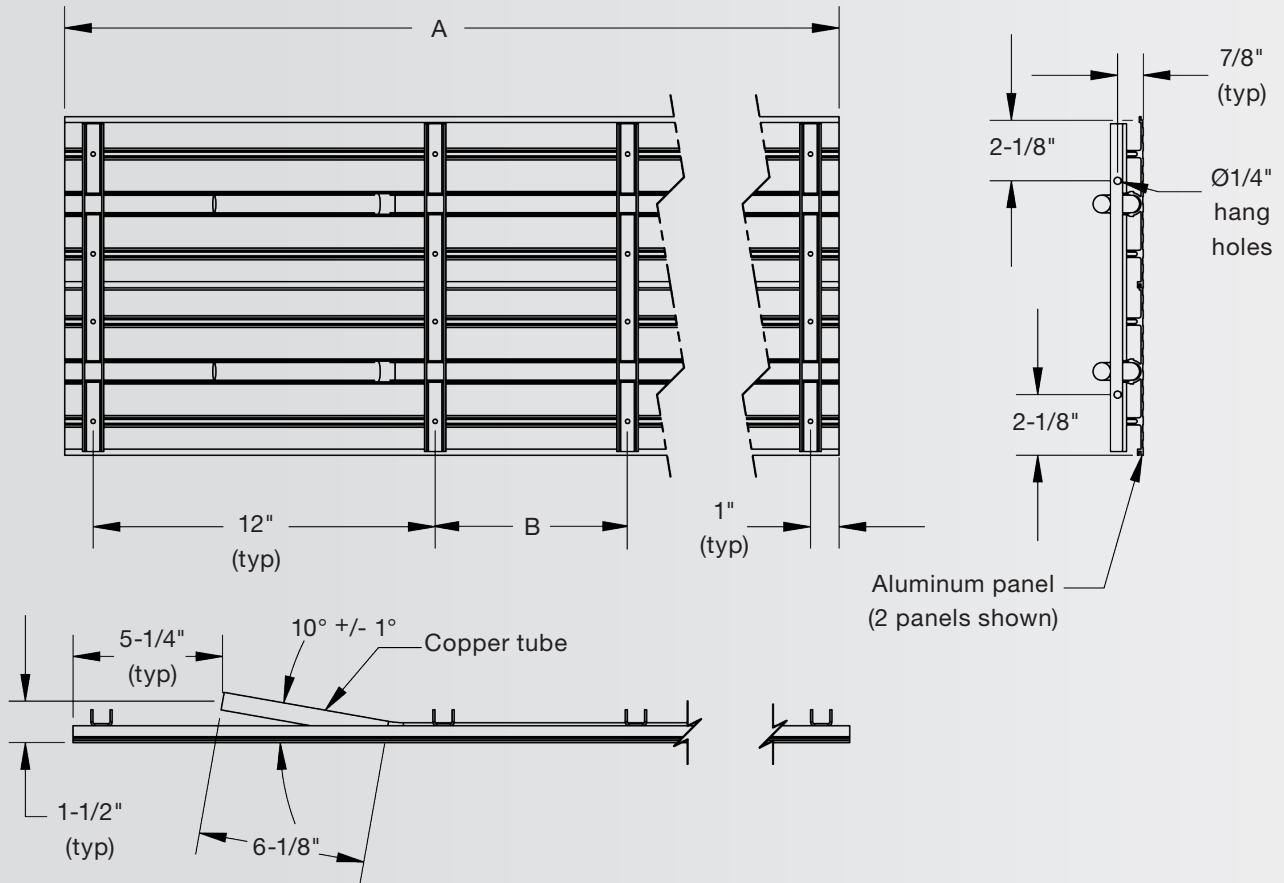

A	B	# of cross channels
4'	n/a	4
5'	17"	5
6'	23"	5
7'	29"	5
8'	23.3"	6
9'	27.3"	6
10'	31.3"	6
11'	26.5"	7
12'	29.5"	7
13'	26"	8
14'	28.4"	8
15'	25.7"	9
16'	27.7"	9

Unit	Panels	Weight (lb/ft)
6" wide	1	1.1
12" wide	2	2.2
18" wide	3	3.3
24" wide	4	4.4
30" wide	5	5.5
36" wide	6	6.6



## Ceiling height de-rating

### Radiant panel height above finished floor/average water temperature.

For radiant panels to perform efficiently, Zehnder Rittling recommends that the average water temperature used with its panels be between 110°F - 190°F (43°C - 88°C) for ceiling heights up to 10 ft (3 m).

This table gives the de-rating percentage for ceiling heights exceeding 13 ft (3900 mm).

As we start moving away from the occupied zone, the radiative energy is absorbed and equalized with the cool surfaces higher up in the ceiling area, reducing the amount of radiative energy remaining by the time it reaches the occupied zone. The increase in ceiling height also reduces the view factor of the radiant panel to the people in the room. Thus, a de-rating factor must be accounted for when mounting panels at high ceiling heights.

Panel height A.F.F. ft (mm)	De-rating %
14 (4200)	3
15 (4500)	6
16 (4800)	9
17 (5100)	12
18 (5400)	15
19 (5700)	18
20 (6000)	21

## Ceiling opening table

Nominal Panel Width	Finished Ceiling Opening
6"	6 1/4"
12"	12 1/4"
18"	18 3/16"
24"	24 1/8"
30"	30"
36"	36"

## Suspension details

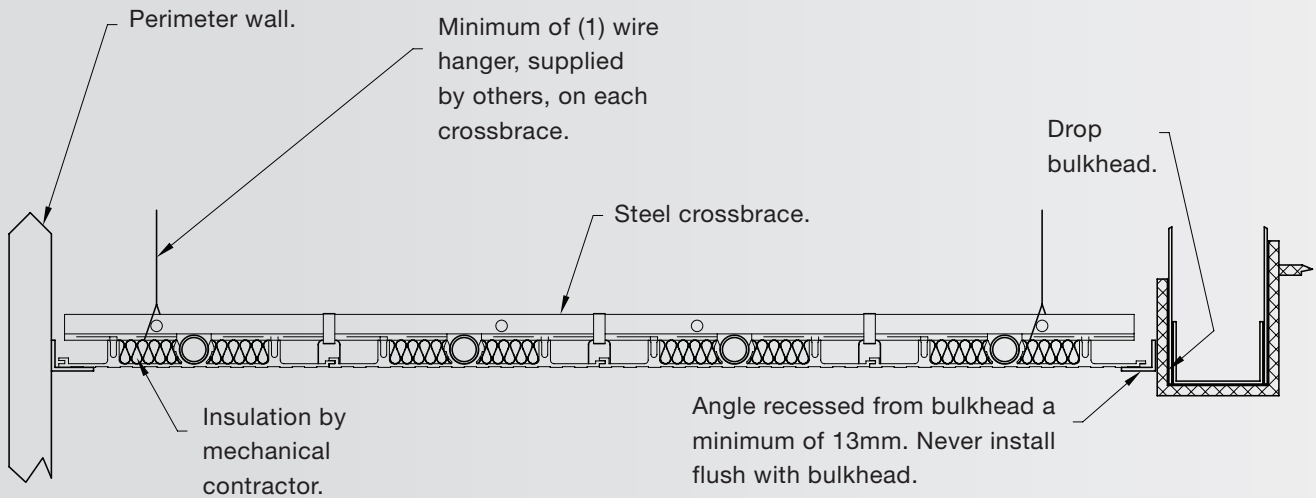
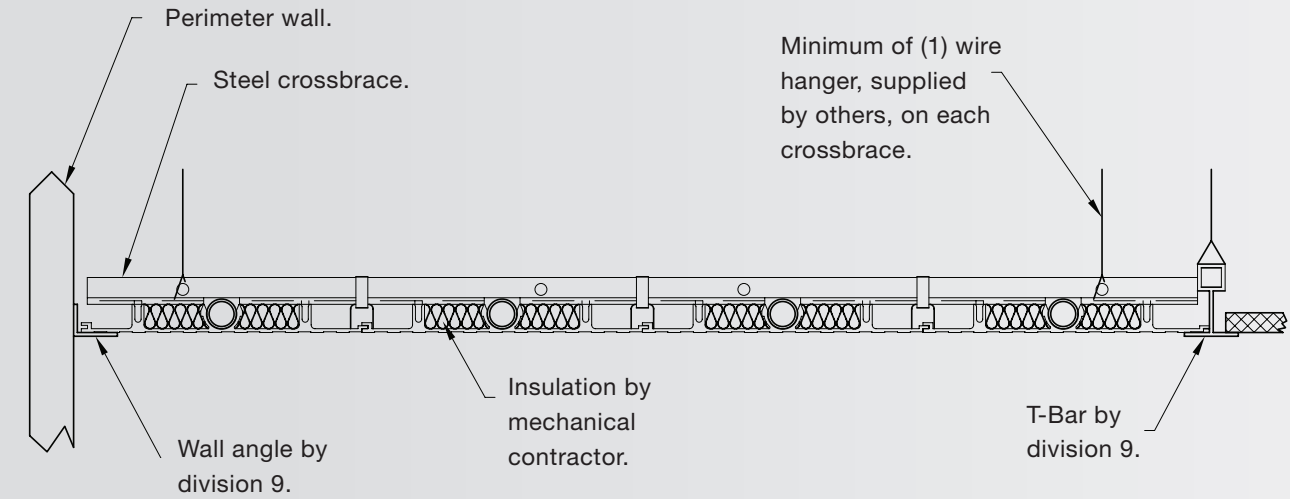

### Notes:

- Access through bulkhead required for connection.
- Typical window pocket installation where panel is higher than ceiling.
- Wall angle molding on both sides.
- Similarly, this detail may be used for a drop soffit where panel is lower than the balance of ceiling.

# Piping components

Typical connections for supply, return, and trimmed panels. Connect with type L-1/2" nominal soft copper tubing. Slip onto panel tubing (nominal 1/2", 5/8" OD).

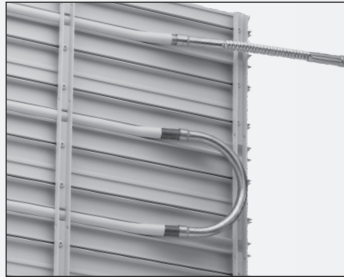

12" flexible panel connector supplied by Zehnder Rittling (field installed).

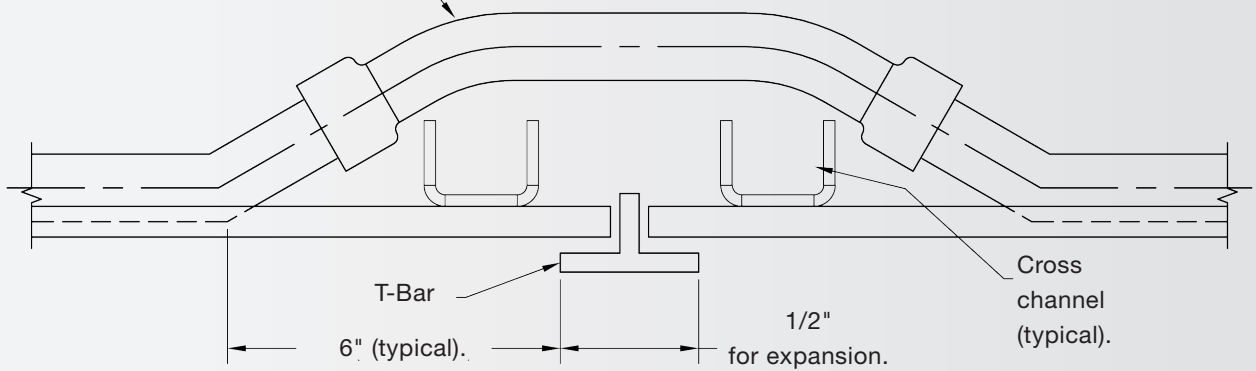
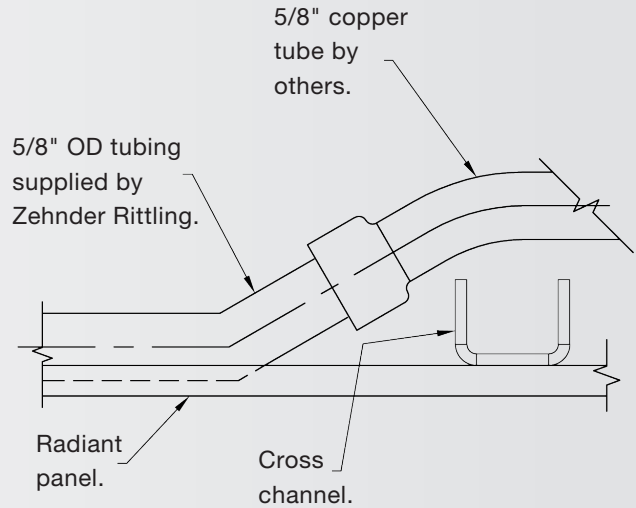

Flexible connections are used between panels when they are installed in series in the same room.

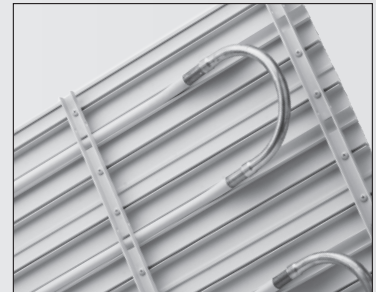
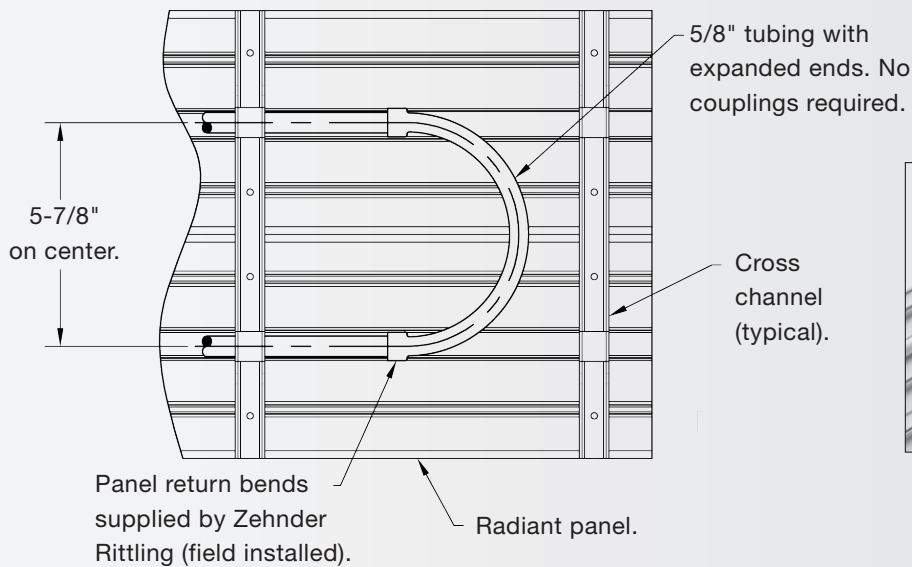

# Mechanical specifications

## 1.0 General

### 1.1 Scope

- .1 To provide an extruded Linear Ceiling Panel system per plans and specifications.

### 1.2 Manufacturers

- .1 Zehnder Rittling
- .2 Alternate manufacturers shall be equal or better than Zehnder Rittling in regard to rows of tubes, capacity, water pressure drop, piping connections and finish.

### 1.3 Quality

- .1 Manufacturer shall be regularly involved in the production of Linear Radiant Ceiling Panel and have available published performance data.
- .2 Submittal drawings shall include supply and return field connection locations along with interconnecting details.

## 2.0 Finished product

- .1 Constructed of 6" wide, 0.0725" thick extruded aluminum panels.
- .2 Total width and number of tubes per design specifications.
- .3 Tube saddles shall be an integral part of aluminum extrusion
- .4 Hot water tubing shall be 1/2" nominal Type L (5/8" OD) copper tubing, snapped into tube saddle and mechanically fastened to aluminum extrusion.
- .5 Extruded aluminum panels shall interlock using tongue and groove connection and mechanically held together with steel cross braces.

- .6 All interlocking of extruded aluminum panels, assembly of cross braces and installation of cooper tubes to be done at factory.
- .7 Panels shall be degreased and chemically phosphatized before application of a durable, attractive electrostatic epoxy powder coating. Color is textured white, low gloss, Protech HX611W565
- .8 Units shall be manufactured in accordance with conformance to ISO 9001:2008 standards.

## 3.0 Equipment Schedule

### 3.1 Linear Radiant Ceiling Panel

- .1 Manufacturer: Zehnder Rittling
- .2 Model: Linear
- .3 Performance: BTUH/Lin. ft. or W/Lin. m
- .4 Width: Specify
- .5 Length: Specify
- .6 Output based on \_\_°F or \_\_°C mean water temperature and 70°F (21°C) air temperature.
- .7 The maximum water pressure drops shall be as follows:
  - .5 gpm - 0.75 ft. of water per 100 ft. tube.
  - 1.0 gpm - 2.45 ft. of water per 100 ft. tube.
  - 1.5 gpm - 4.93 ft. of water per 100 ft. tube.
  - 2.0 gpm - 8.11 ft. of water per 100 ft. tube.
  - 2.5 gpm - 11.98 ft. of water per 100 ft. tube.
  - 3.0 gpm - 16.48 ft. of water per 100 ft. tube.

## 4.0 Installation

- .1 The mechanical contractor shall cooperate with all other trades to ensure an aesthetically pleasing ceiling installation.
- .2 All interconnecting of radiant panels by the mechanical contractor shall consist of 1/2" nominal (5/8" OD)

flexible cooper interconnects and return U-bends, supplied by Zehnder Rittling.

- .3 Hot water supply tubing to connect first to panel closest to perimeter wall. Multiple panels are to be connected to ensure serpentine flow across entire zone. Individual serpentine panels connected in series are unacceptable for multiple panel zones.
- .4 All radiant panels shall be installed continuously from wall-to-wall. All radiant panels shall be trimmed in the field to allow enough room for expansion while maintaining adequate panel end coverage with architectural moldings.
- .5 All radiant ceiling panels shall be installed by workers wearing clean, white gloves.
- .6 All system piping shall be thoroughly cleaned, flushed, drained and refilled before radiant ceiling panels are connected to system
- .7 Panels to be pressure tested per engineer's specifications.
- .8 All active panels shall be covered with a 1" minimum thickness of 1 pound density insulation after connection and testing of panels is complete.
- .9 Minimum of one wire hanger per cross brace. Minimum of two per panel.

## Warranty

Zehnder Rittling guarantees its products to be free from defects in material and workmanship for a period of one years from date of shipment from our factory.

Should there be any defects in the good(s), the purchaser should promptly notify Zehnder Rittling. Upon receipt of written consent from Zehnder Rittling, the purchaser shall return the defective good(s) to the factory for inspection with freight prepaid. If inspection shows the goods to be defective, Zehnder Rittling will at its discretion repair or replace the said item(s).

Defects arising from damage due to shipment, improper installation, negligence or misuse by others are not covered by this warranty.

This warranty is extended only to the original purchaser from Zehnder Rittling.

**IMPORTANT: Approved submittal documentation, specific to each project, supersedes the general guidelines contained within this document.**

