



www.Berner.com

BERNERTM
AIR CURTAINS

**Architectural
High Performance 10**
Air Curtain Series #AHD10



Installation & Maintenance Instructions

TABLE OF CONTENTS

I. UNCRATING.....	2
II. GENERAL MOUNTING INSTRUCTIONS	4
III. WALL MOUNTING	5
IV. SUSPENDED MOUNTING	5
V. ELECTRICAL CONNECTIONS	6
VI. FIELD CONNECTIONS	6
VII. OPERATING INSTRUCTIONS.....	7
INTELLISWITCH TM	
QUICK START OPERATION	9
FAQ's (FREQUENTLY ASKED QUESTIONS)	11
VIII. MAINTENANCE AND CLEANING.....	8
IX. SERVICE	8
X. TROUBLESHOOTING	13
XI. APPENDIX	
A. SERIAL NETWORK CONNECTION (PREVIOUSLY MASTER / SLAVE CONNECTION)	14
B. REMOTE MOUNTED DISPLAY FACEPLATE	14
C. INFRA-RED REMOTE CONTROL	14
XII.WARRANTY	16

Thank you for choosing Bernier.

Berner International has been saving energy and creating healthy, comfortable environments for our customers for over 60 years. Bernier offers unmatched quality, performance, and dependability—not to mention our service. At Bernier, we stand behind our products.

READ ALL INSTRUCTIONS BEFORE INSTALLING OR USING AIR CURTAIN

II-260
June, 2017



Architectural High Performance 10 Air Curtain (Air Door)

WARNING: TO REDUCE THE RISK OF FIRE, ELECTRIC SHOCK OR INJURY TO PERSONS, OBSERVE THE FOLLOWING:

- A. Read all instructions before installing or using this air curtain.
- B. Use this unit only in the manner intended by the manufacturer and described in this manual. Any other use not recommended by the manufacturer may cause fire, electric shock, or injury to persons. If you have any questions, contact the manufacturer.
- C. Before servicing or cleaning unit, switch power off at service panel and lock the service disconnecting means to prevent power from being switched on accidentally. When the service disconnecting means cannot be locked, securely fasten a prominent warning device, such as a tag, to the service panel.
- D. Installation work and electrical wiring must be done by qualified person(s) in accordance with all applicable national and local codes having jurisdiction, including fire-rated construction. See page 6, ELECTRICAL CONNECTIONS (NEC Code ANSI/NFPA No. 70).
- E. When cutting or drilling into wall or ceiling, do not damage electrical wiring and other hidden utilities.
- F. To reduce the risk of fire, do not store or use gasoline or other flammable vapors and liquids in the vicinity of the air curtain.
- G. This air curtain is hot when in use. To avoid burns, do not let bare skin touch hot surfaces. Keep combustible materials, such as furniture, pillows, bedding, papers, clothes, etc. and curtains at least 1 inch from the top, back, front, sides and at least 6 feet from the discharge of the air curtain.
- H. Extreme caution is necessary when any air curtain is used by or near children or invalids, and whenever the heater is left operating unattended.
- I. Do not operate any air curtain after it malfunctions. Disconnect power at the service panel and have the air curtain inspected by a reputable electrician before reusing.
- J. To disconnect the air curtain, turn controls to "off", and turn off power to the air curtain circuit at main disconnect panel.
- K. Do not insert or allow foreign objects to enter any ventilation or discharge opening as this may cause an electric shock or fire, or damage the air curtain.
- L. To prevent a possible fire, do not block the air intake or discharge of the air curtain in any manner.
- M. The air curtain has hot and arcing or sparking parts inside. Do not use it in areas where gasoline, paint, or flammable vapors or liquids are used or stored.
- N. This heater may include an audible or visual alarm to warn that parts of the heater are getting excessively hot. If the alarm sounds (or illuminates), immediately turn the heater off and inspect for any objects on or adjacent to the heater that may have blocked the airflow or otherwise caused high temperatures to have occurred. **DO NOT OPERATE THE HEATER WITH THE ALARM SOUNDING (OR ILLUMINATING).**

I. UNCRATING

Carefully examine the carton(s) for damage. If the carton is damaged, immediately notify the shipping company. **Do not delay in filing claim.** If the air curtain(s) were shipped on wooden skids, remove protective wood and banding straps securing the carton(s) to the skid. Open the carton(s) and remove all protective packaging. If the unit will be wall mounted, remove and save the two (2) locking screws from the back corners and detach the wall mounting plate. **See Figure 1.**

If the unit will be wall mounted, remove and save the two (2) locking screws from the back corners and detach the wall mounting plate. **See Figure 1.**

Immediately verify that the electrical rating nameplate located on the cover matches electrical power supply available. Retain the shipping carton(s) until the air curtain(s) are installed and properly operating.

ACCESSORIES: If the air curtain(s) were ordered with optional electrical accessories, the accessories will be found in the carton containing the air curtain or in a separate carton(s) accompanying the air curtain(s). Check all of the cartons/skids for accessories before discarding.

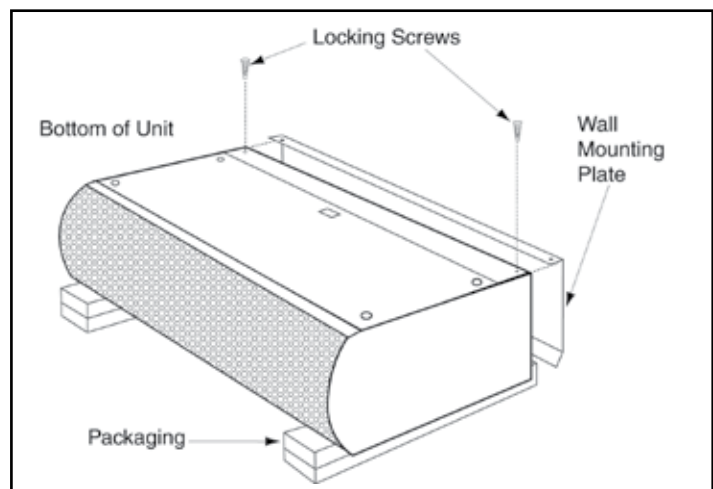
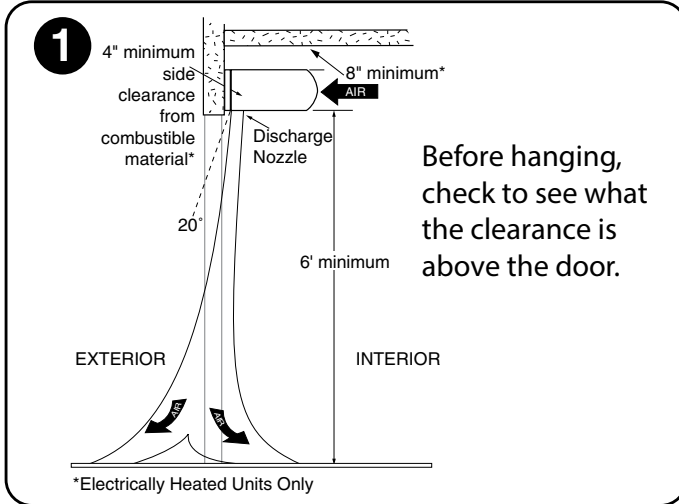

Figure 1

Simple to Install

Easy to operate & maintain



For more information see page 4

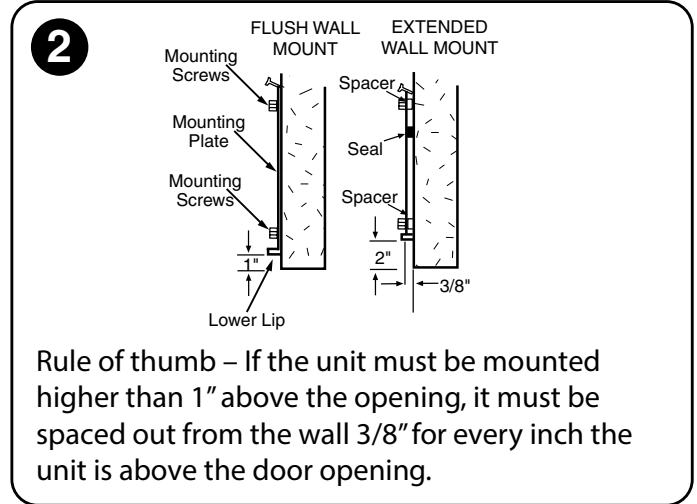

For more information see page 4

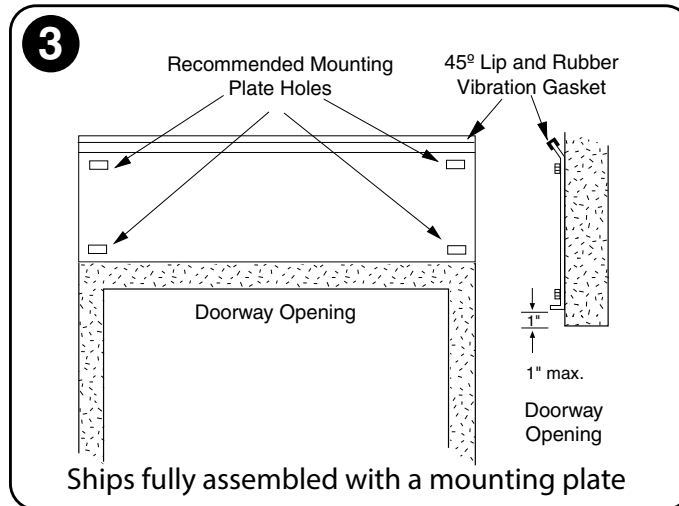

For more information see page 5

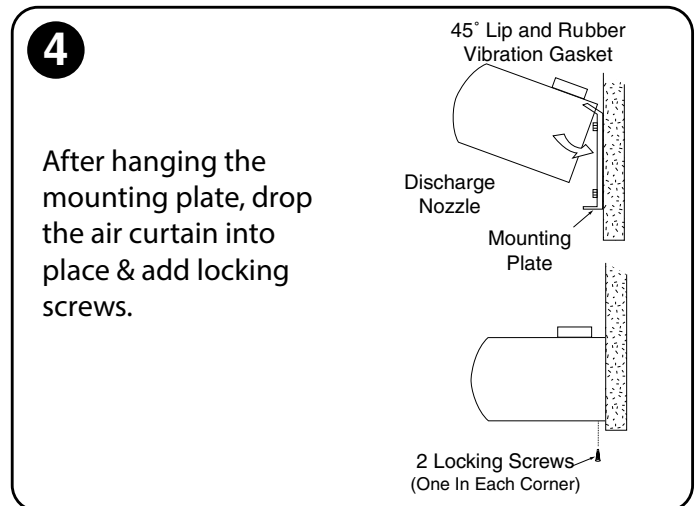

For more information see page 5

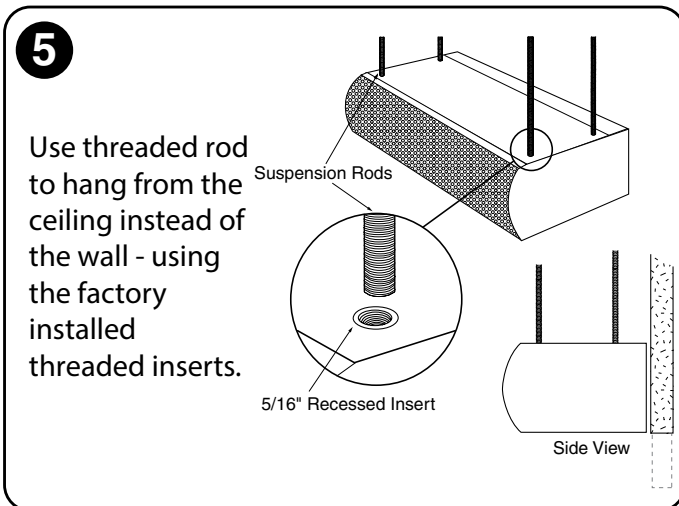

For more information see page 5

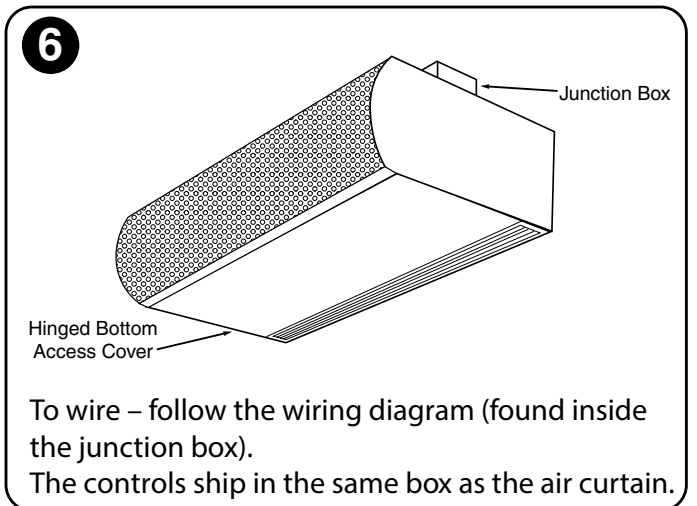

For more information see page 6

II. MOUNTING INSTRUCTIONS (General)

INDOOR MOUNTING ONLY -

The Architectural High Performance 10 Air Curtain is designed to be an effective barrier against cold drafts in the winter and hot air in the summer, flying insects and airborne contaminants.

To achieve optimum protection, the air curtain should be mounted on the inside of the building, flush to the wall and as close to the top of the door opening as possible. To ensure peak performance, keep the air stream free of obstructions.

The air curtain will not perform properly if negative air pressure exists in the building. Under these conditions, a means for makeup air to the building must be provided so that the air pressure on both sides of the opening is in balance.

Before mounting the air curtain, check the supporting structure to verify that it has sufficient load-carrying capacity to support the weight of the air curtain(s). The mounting hardware (supplied by others) should be capable of supporting a minimum of three (3) times the weight of the air curtain.

See Table 1.

IMPORTANT: A minimum of 1" is required above the top of the air curtain for the installation and removal of the inlet screen.

- A. When determining the mounting location for the air curtain(s), make sure that nothing interferes with the curtain of air developed when the discharge vanes are directed from 0° to 20° toward the door opening. If the air stream strikes any obstruction (the top edge of the doorway, a door opening device, etc.), the effectiveness of the air curtain will be greatly reduced. See Figure 2.
- B. For optimum performance, the bottom of the air curtain (discharge nozzle) should be no more than 1" above the top of the door opening with the air curtain(s) mounted flush to the wall. If the air curtain must be mounted higher, it must be spaced out from the wall 3/8" for every inch the air curtain is above the door opening. See Figure 3. For optimum protection, any void between the air curtain and the wall should be sealed along the full length of the air curtain.
- C. Do not block (obstruct) the air intake grill. Insufficient airflow can cause the unit to overheat.
- D. **Electric heated air curtain(s) shall:**
 1. Have a minimum clearance of at least 4" from the sides and 8" from the top for electric heated units.
 2. Have a minimum clearance of at least 6' between the bottom of the air curtain and the floor.
 3. Be installed Indoors Only.
- E. Proceed to either **Section III - WALL MOUNTING** or **Section IV - SUSPENDED MOUNTING**

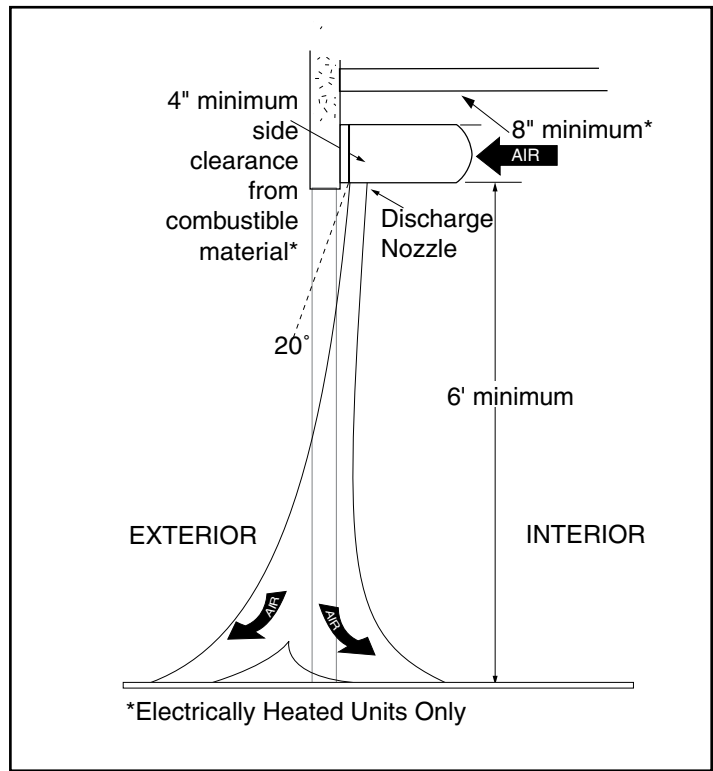

Figure 2

WEIGHT IN POUNDS			
Model	Unheated	Electric	Steam/Hot Water
AHD10-1036	65	71	98
AHD10-1042	68	74	104
AHD10-1048	70	76	109
AHD10-2048	95	107	135
AHD10-2060	125	137	171
AHD10-2072	130	142	182
AHD10-2084	140	152	198
AHD10-2096	145	157	209
AHD10-3096	165	183	229
AHD10-3108	170	188	241
AHD10-3120	175	193	249

TABLE 1 - Weight Chart

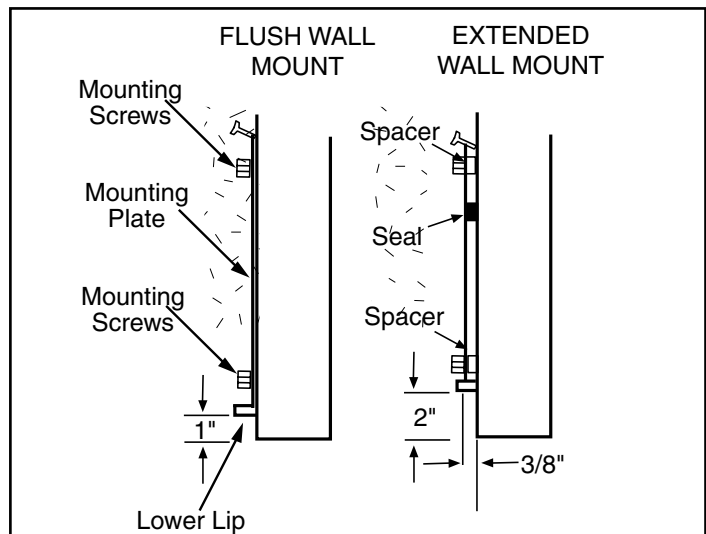

Figure 3

III. WALL MOUNTING

A. PREPARATION

1. Position and center the mounting plate over the door opening. The mounting plate must be positioned with the 45° lip and the rubber vibration gasket on top.
2. Mark and drill holes on the mounting plate where the wall will provide sufficient support for the Air Curtain. A minimum of four holes close to the corners is recommended. **See Figure 4.** The mounting hardware (supplied by others) must be capable of supporting a minimum of three times the net weight of the Air Curtain. **See Weight Chart, Table 1.**
3. Drill the four holes as marked on the wall and attach the mounting plate with anchors (if used) and the four mounting screws (provided by others).

B. ATTACHING THE AIR CURTAIN TO THE MOUNTING PLATE

1. Raise the unit over the door (air discharge nozzle facing down) and on to the mounting plate. First, tilt the unit upward matching the top recessed edge of the unit to the top 45° angled lip on the mounting plate. **See Figure 5.**
2. Lower the unit into place, allowing it to rest on the lower lip of the mounting plate.
3. After the unit is securely attached to the mounting plate, re-install the two (2) locking screws at the bottom corners. **See Figure 5.**
4. Proceed to **Section V - ELECTRICAL CONNECTIONS**

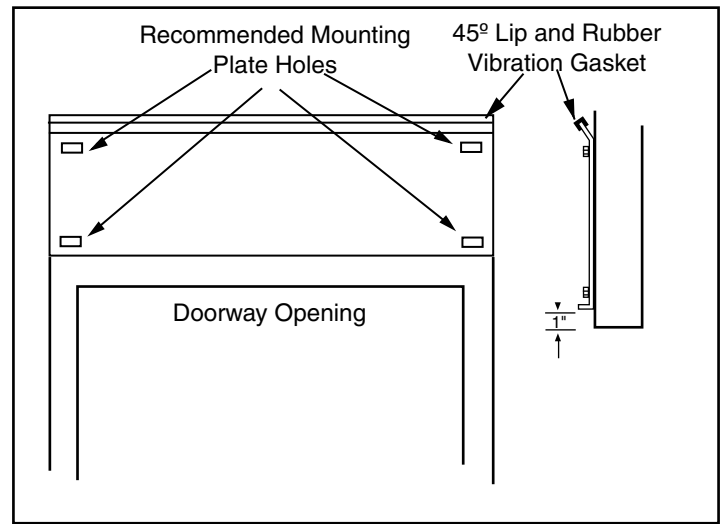

Figure 4

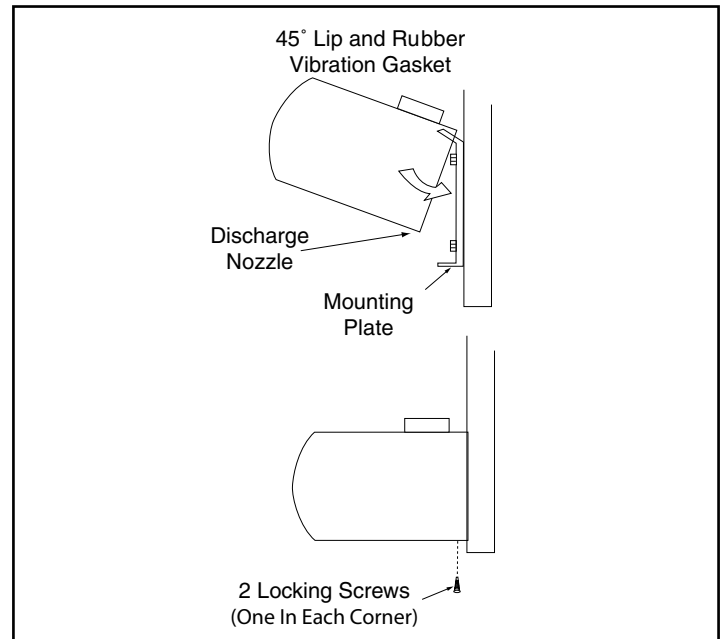

Figure 5

IV. SUSPENDED MOUNTING

- A. When the air curtain is top mounted, the wall mounting plate is designed to store on the back of the air curtain for future use. **See Figure 5.**
- B. For top mounting using suspension rods, four (4) factory installed 5/16" threaded inserts are located on the top of the unit. **See Figure 6.**
- C. Install 5/16" threaded rods, or other suitable hardware at a location sufficient support the Air Curtain. The mounting hardware (supplied by others) must be capable of supporting a minimum of three times the net weight of the Air Curtain. **See Weight Chart, Table 1.**
- D. Attach 5/16" threaded rods, or other suitable hardware to the top mounted threaded inserts.
- E. Proceed to **Section V – ELECTRICAL CONNECTIONS**

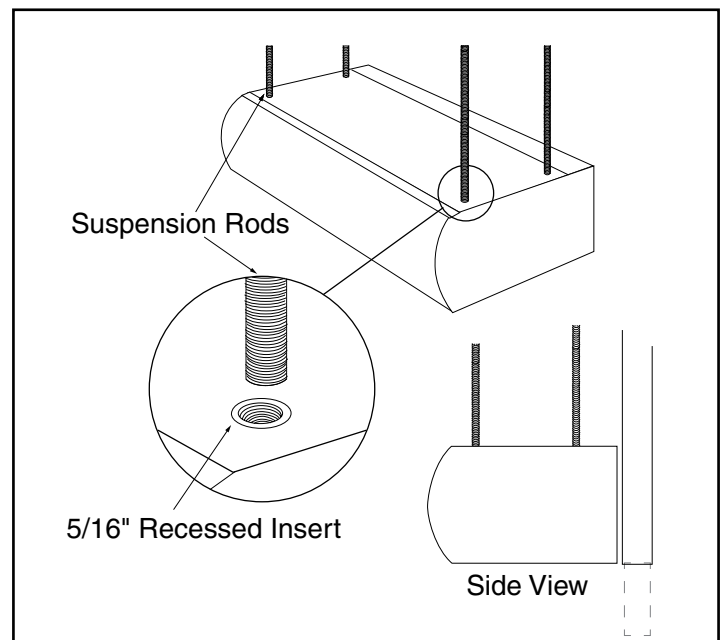

Figure 6

V. ELECTRICAL CONNECTIONS

All electrical wiring and connections **MUST** be performed by qualified personnel in accordance with the latest edition of the National Electrical Code ANSI/NFPA No. 70 or, in Canada, the Canadian Electrical Code, Part 1-C.S.A. Standard C22.1 and local codes and regulations.

MAKE SURE THE CORRECT VOLTAGE AS MARKED ON THE UNIT IS USED.

- A. A separate line voltage supply with a suitable branch circuit protection device should be run directly from the main electrical panel to the unit. A disconnect switch for each branch circuit is a required part of this installation. See the voltage label on the unit for circuiting and total electrical load. The wiring diagram is located in the junction box. **See Figure 7.**
- B. All field wiring must be copper with a minimum insulation of 60°C within approved conduit. If any of the wire supplied with the unit must be replaced, it must be replaced with copper wiring with a minimum insulation of 90°C.
- C. Electric, steam and hot water heated air curtains are factory equipped with an air curtain mounted solid state temperature sensor cable located in the junction box. Depending on where the temperature is to be measured, the sensor may be left on the endplate or positioned elsewhere. Do not put any clamps on the rubber coated tip.
- D. Remove the junction box cover.
- E. Connect all supply and control circuit wires according to the wiring diagram provided.

NOTE: For Electric heated air curtains provided with the optional remote thermostat, mount and wire the thermostat according to thermostat instructions and wiring diagram.

For Serial Network Connection (previously Master/Slave Connection) – see Appendix A, “Serial/Network Connection.” **NOTE: The air curtain must have been ordered from the factory with this option.**

For Remote Mounted Display Faceplate – If operation of the Intelliswitch™ is to be through a Factory Ordered Remote Mounted Display Faceplate, see Appendix B, “Remote Mounted Display Faceplate.”

For Electric, Steam and Hot Water air curtains - proceed to **Section VI - Field Connections**, otherwise proceed to **Section VII - Operating Instructions**

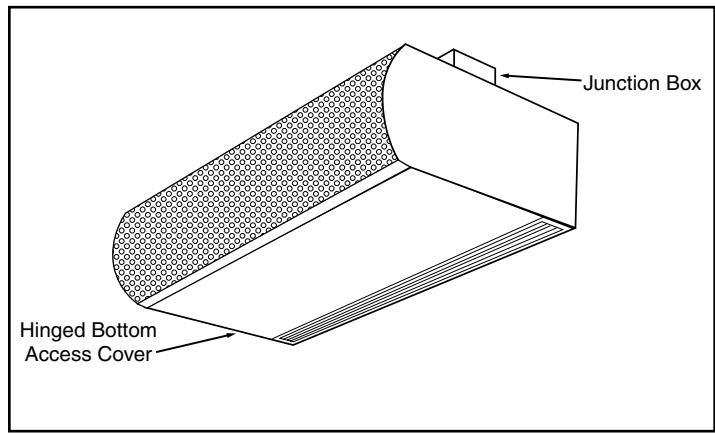

FIGURE 7 - Electrical Connections

VI. FIELD CONNECTIONS

A. ELECTRICALLY HEATED MODELS

The heater circuit may be controlled by a remote thermostat or manually through the Intelliswitch™ located on the discharge side of the air curtain. Overheating protection is provided by auto reset thermal cutouts built into the heater coil assembly (see the wiring diagram located in the junction box). **See Figure 7.**

B. STEAM AND HOT WATER HEATED MODELS

The coil solenoid may either be controlled through the Intelliswitch™ or independently. The Intelliswitch™ is capable of providing the same voltage used for the motor to power a solenoid up to a 5 amp load on the call of heat. The heater circuit may be controlled by the unit mounted sensor, a remote mounted thermostat or manually through the Intelliswitch™ located on bottom access cover of the air curtain. Piping should be done in accordance with local codes, regulations and standard practices. Connect the building system supply and return to the 1" MPT nipples on the heating coil. **See Figure 8.**

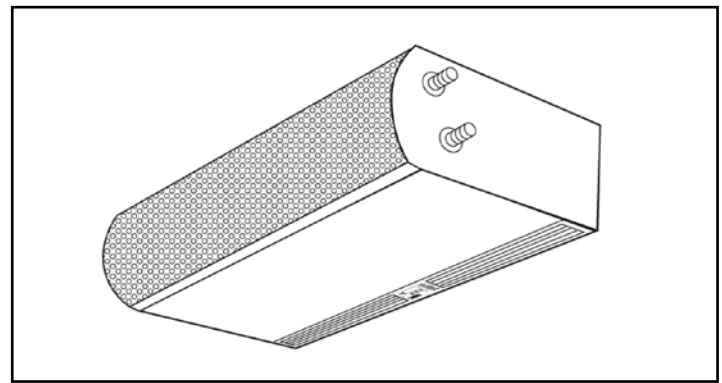

FIGURE 8 - Steam/Hot Water Connections

VII. OPERATING INSTRUCTIONS

A. GENERAL OPERATION

This air curtain comes with a built-in Berner Intelliswitch™ Digital Controller to operate the fan activation, fan speed selection, and heat activation. The air curtain must be properly installed before it is used.

1. For detailed instructions on how to operate the Intelliswitch™ and select from a list of standard modes of control, proceed to the following pages:

Quick Start Operation Guide, page 9

Frequently Asked Questions (FAQs), page 11

NOTE: For a Detailed Programming Guide, go to

www.Berner.com/Intelliswitch™

2. Unheated units will have the fans activated by a door switch or sensor. The unit speed can be selected from the Intelliswitch™ display.
3. Heated units will have fans activated by a door switch or sensor, but may also be activated by the thermostat in Comfort Plus Mode. The unit speed can be selected from the Intelliswitch display.
4. To operate using the **Berner Air Curtain App**
NOTE: The air curtain must have been ordered from the factory with the wi-fi controller to use this option. The wi-fi controller allows air curtain(s) to be programmed & operated via smart phone. Requires on-site, secure wi-fi connection (provided by others).

Download the "Berner APP" to your smart phone from the Google Play store. Follow the prompts. *Berner recommends having the on-site user(s) set-up the Berner App on his/her smart phone.*

B. AIR STREAM ADJUSTMENT

1. With the air curtain operating and the door in its full open position, check to see that nothing is obstructing the airflow at the discharge nozzle vanes.
2. Find the air stream split location. Hold a handkerchief by its corners, approximately 12" above the floor. Gently move the handkerchief back and forth in the doorway. Make sure the air is being directed to both the inside and the outside. **See Figure 9.** The split location is indicated where the handkerchief is vertical with minimal or no fluttering.
3. The split location should be approximately 3" outside the doorway. If necessary adjust the discharge nozzle vanes by de-energizing the unit, loosening the nozzle vane locking screws and adjusting vanes.

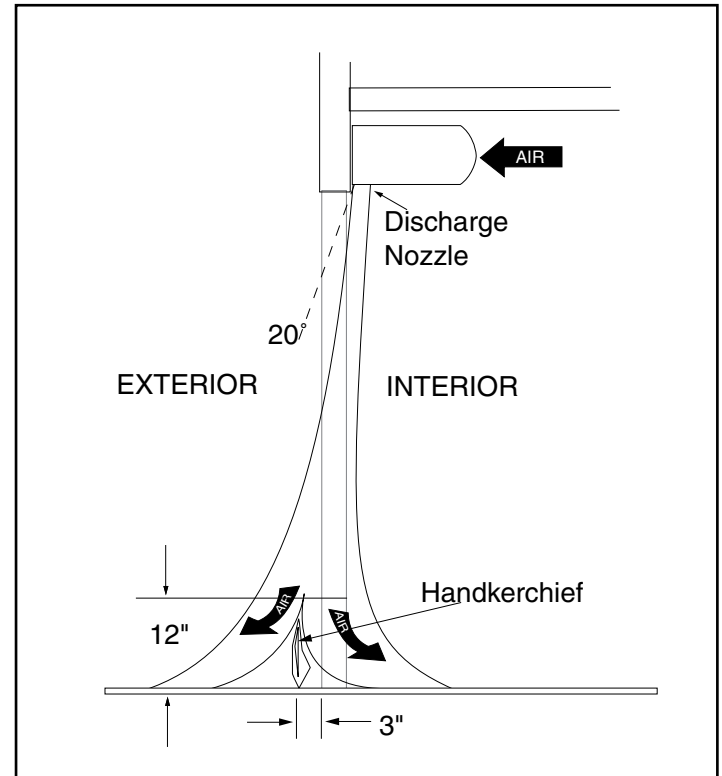

Figure 9

VIII. MAINTENANCE & CLEANING

CAUTION: ELECTRIC SHOCK HAZARD Disconnect power whenever servicing unit. More than one disconnect may be required to de-energize unit.

Keep your air curtain operating at peak efficiency by cleaning the blower wheels, motor(s) and intake grill. Buildup of dust on the blower wheels can cause vibration, noise and excessive wear on the motor bearings. The frequency of cleaning will depend on the environment where the unit is operating.

Dirty, dusty or greasy environments could require a cleaning schedule of once every two months. If the environment is not that dirty, the unit(s) should be scheduled for cleaning a minimum of once every (6) months.

A. PERFORMING PREVENTIVE MAINTENANCE

1. **Disconnect the power to the unit.**
2. Remove the intake grill by removing the locking screw on each end of the unit. Lift the intake grill up and then towards you. **See Figure 10.**
3. Open the bottom access panel by removing the Phillips head screws on the bottom of the unit. Vacuum and scrape (if necessary) to remove the build-up of dirt and debris. The motor(s) are permanently lubricated and require no additional lubrication. Re-install the cover and intake grill.
4. Switch the power on after cleaning.

CAUTION: STAND CLEAR OF THE UNIT OR WEAR SAFETY GOGGLES AS LOOSE DEBRIS MAY BE PRESENT AND MAY EXIT THE NOZZLE.

CAUTION: ELECTRIC SHOCK HAZARD Disconnect power whenever servicing unit. More than one disconnect may be required to de-energize unit.

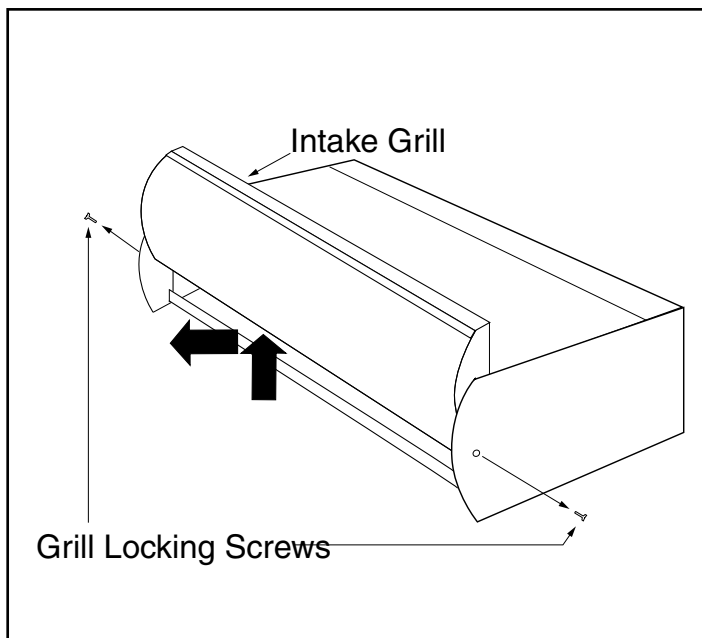

Figure 10

IX. SERVICE

Any service performed on the ARCHITECTURAL HIGH PERFORMANCE 10 Series air curtain **MUST** be done by qualified personnel. Berner air curtains require very little servicing. All parts are easily accessible for periodic inspection and maintenance. Units should be cleaned at least twice a year. Your particular application (the amount of dirt and dust in the air) and location of the unit(s) will determine how often your unit(s) will need to be cleaned and serviced. All motors have permanently lubricated, sealed, sleeve bearings and require no maintenance.

QUICK START INSTRUCTIONS

For your *Berner Air Curtain with Intelliswitch™*

www.Berner.com/intelliswitch



NOTE – to navigate use up/down to select setting and left/right to change setting
Mode/Fan Speed:

Mode: Select your mode of operation (see steps on page 2)

Fan Speed: Sets the speed of the fan

Delay Time: Amount of time the air curtain is to run after the door closes

Temp Set: Amount of heat and time the air curtain is to run after the door closes

Start Time: Programmable time of day air curtain becomes active

Stop Time: Programmable time of day air curtain stops running

T-Stat Mode: Set only heat or heat & fan

Set Time/Day: Programmable clock

IMPORTANT NOTE!

If you air curtain unit is in “Locked” mode when you receive it:
Press and hold the left and right arrows simultaneously for 5 seconds to unlock.

STEP ONE



To Start: Press the Down Arrow button once.
NOTE: To change from "Mode" to "Fan Speed" press the down arrow twice.

STEP TWO



Use the Left and Right Arrows to scroll through the 8 available modes of operations

5 Standard Mode of Operation Options:

OFF

Door opens: The air curtain is off
Door shuts: The air curtain is off

ON

Door opens: The air curtain activates
Door shuts: The air curtain continues to run

AUTO

Door opens: The air curtain activates
Door shuts: The air curtain turns off

DELU

Door opens: The air curtain activates
Door shuts: The air curtain continues to run for a minimum of 60 seconds

PLUS

For heated units only

Door opens: The air curtain and heater activate and run at set speed
Door shuts: The air curtain continues to run for a minimum of 60 seconds. If thermostat is not satisfied, air curtain and heater continue to run until thermostat is satisfied. If thermostat drops below set temperature, the heater and air curtain will run until thermostat is satisfied.

3 Customizable Mode of Operation Options:

See www.berner.com/intelliswitch for programming directions
(Section 5, Program Menu).

STEP THREE



Once the **Mode of Operation** is selected, press the "OK" button

INTELLISWITCH™ FAQ's (Frequently Asked Questions)

www.Berner.com/intelliswitch

WARNING: TO REDUCE THE RISK OF FIRE, ELECTRIC SHOCK OR INJURY TO PERSONS, OBSERVE THE FOLLOWING: Before servicing or cleaning unit, switch power off at service panel and lock the service disconnecting means to prevent power from being switched on accidentally. When the service disconnecting means cannot be locked, securely fasten a prominent warning device, such as a tag, to the service panel.

Even though every Architectural High Performance 10 is individually tested at the factory before shipment, on occasion improper functionality may be experienced. Here is a list of common questions:

Q. Why can't I change my settings?

A. The Intelliswitch™ may be locked. If the Lock light is illuminated, the control is locked. To unlock, press and hold the left & right arrows simultaneously for 5 seconds. The Lock mode can also be protected with a PASScode. If the PASScode option is on, an attempt to unlock the control will display PASS and then a 0000 prompt. A four-digit code (available in the installation instruction book Appendix) must then be entered to unlock the control. Use the up and down arrows to select a number and the left and right arrows to select the digit to edit. Press OK when done. Note: If the AutoLock setting is on, the control will re-lock if there is no activity after 5 minutes.

Q. Why won't my heat work, even though fans are running?

A. The thermostat(s) or speed sensor may need adjusted or replaced.

- 1.) Make sure that the thermostat probe and/or remote thermostat are in the "On" position and set above ambient (room) temperature.
- 2.) Check internal and external thermostat status in the Diagnostics Menu for a faulty thermostat. To do this, hold the right arrow for five seconds until DIAG appears, then arrow down to the ts setting, if it displays "1" then the thermostat(s) is working (there is a call for heat).
- 3.) If no external thermostat is used, check to see if the internal probe is attached to the control board. Disconnect power to the unit, remove the display board and check that the beige sheathed cable is attached at both ends. If the thermostat(s) and settings are correct and you are still not getting heat, then check to see the fan speed. To do this, press the down arrow to reach the Mode/Fan speed setting. Use the right and left arrow to change the fan speed.
- 4.) Check to see if you can adjust the fan speed. If the speed sensor is bad there will be no speed control and the Intelliswitch will not let the heat come on. If it is too difficult to determine a change in speed, the speed sensor can be checked by entering the DIAG menu and checking the first error code. If ER 10 displays, the speed sensor is recognized by the Intelliswitch. If the code ER 11 is displayed, the Intelliswitch does not recognize the sensor, and it may be faulty or need adjusted closer to the trigger bar. Turn off the power to the unit and remove the screen to check the distance between the sensor and the trigger located on the left side of the motor (use the bottom access cover for steam/hot water heated units). The sensor should be less than 1/16" from the trigger face. Check distance at both ends of trigger. Adjust if necessary.
- 5.) If there is still no heat or speed control, you may need a new speed sensor: consult factory.

Q. Why won't the Intelliswitch™ light up?

A. There may not be power to the control.

- 1.) Check to see if the main power is turned on to the unit. Your air curtain may have multiple disconnects, be sure all are turned on.
- 2.) Verify that there is power to the board. **NOTE: ONLY QUALIFIED PERSONS SHALL CHECK POWER IN THE UNIT WITH THE POWER ON.** The power terminals are located directly behind the display. Remove two Phillips screws from the Intelliswitch display to expose the power terminals and check the line voltage at spade terminals L2 and 120, 208 or 240 (depending on the voltage supplied to the unit).
- 3.) Check the ribbon cable connections to the display board for a loose connector or improperly connected cable (see Installation Instructions for correct cable connection).
- 4.) If display still doesn't light, unplug the speed sensor and thermostat probe (if a heated unit) from the control board. If the display lights, plug one component back in at a time to see which one may be shorted. The faulty component will make the display go blank again.
- 5.) If there is line voltage power at the board terminals, the ribbon cable is correctly connected, the speed sensor and the thermostat are working, and it is still not working, you may need a new circuit board: consult factory.

Q. Why won't my fans shut off?

A. The Intelliswitch™ may be in the wrong mode or mis-wired.

- 1.) Check to see if the control is in the "ON" mode, if it is, then change the Mode to another setting.
- 2.) The T-Stat Mode may be set to the "both" setting and the thermostat is calling for both Fan and Heat, change the T-Stat Mode to "HEAT".
- 3.) If there is a door switch and the unit is in a mode that is activated by it, there could be a short, mis-wiring or mixup in components. Close the door and check the door switch status in the Diagnostics menu. Hold the right arrow for five seconds until DIAG appears, then arrow down to the ds setting, if it displays "1" then the door switch signal is closed (there is a call for fan). If the door is closed, the signal should be "0" or open.
- 4.) There could be a short in the field connections to the door switch or the door switch leads could be mis-wired. To test, disconnect the door switch connection at the unit. Opening the wiring tray on top of the unit and be cautious of high voltage connections. Disconnect the blue wires labeled 9 & 10 from the field wiring to the door switch or make sure they are not tied together. There is no danger of getting shocked because the signal is 5 volt dc. Be sure not to touch the blue wires to anything metal (or grounded). The unit should shut off when it is in

INTELLISWITCH™ FAQ's Continued (Frequently Asked Questions)

www.Berner.com/intelliswitch

any mode that is activated by the door switch.

5.) If the air curtain is heated, make sure that the thermostat isn't wired to the door switch leads. Door switch leads are blue and labeled 9 & 10.

Q. How can I check the door switch to be sure it's working?

A. The Intelliswitch™ may be in the wrong mode, be mis-wired or have a faulty door switch.

1.) Test the wiring and controller function at the same time first. Locate the door switch and open its wiring compartment by removing the two screws holding on the back cover. There should be two wires connected to screws inside the switch. There is no danger of getting shocked because the signal is 5 volt dc. Be sure not to touch the wires to anything metal (or grounded). Either disconnect both wires from the screws (noting which screws the wires are under) and touch them together (with air curtain in "Auto" mode) or make a short jumper wire and touch the jumper to both screws at the same time to see if air curtain comes on. If it does, the controller and wiring work.

2.) If the wiring and unit pass the function test, the problem could be either misalignment or a faulty door switch. On a magnetic reed switch check for magnet alignment, for plunger/roller type switch, check contact engagement with door.

3.) If you have access to an electrical test meter, the door switch contacts can be tested for continuity when the door switch wires are disconnected from the unit.

Q. Why won't my heat shut off?

A. The Intelliswitch may need adjusted, have been mis-wired or have a faulty thermostat.

1.) Heat is activated by one of two thermostat connections. To test the internal thermostat set the external thermostat to OFF. The settings of the unit mounted thermostat probe are accessed through the display. Press the down arrow until the Temp Set indicator lights up; check if the temperature setting and unit of measure are correct. Test to see if it shuts off by setting the thermostat temperature to OFF or lower than the room temperature.

2.) If an external thermostat is connected to the unit, there could be a short in the field connections or the thermostat leads may be mis-wired. To test the external thermostat set the internal thermostat to OFF. Disconnect the external thermostat connections at the unit. Open the wiring tray on top of the unit and be cautious of high voltage connections. Disconnect the orange wires labeled 6 & 7 from the field wiring to the thermostat or make sure they are not tied together. There is no danger of getting shocked because the signal is 5 volt dc. Be sure not to touch the orange wires to anything metal (or grounded). The

heat should shut off when the wires are separated.

For more complex troubleshooting of either thermal cutouts or heater contactors, please consult a qualified electrician or the factory.

Q. Why didn't the Intelliswitch™ save the changes I made to a program?

A. If a program is active (a dot is illuminated by one of the clock digits), changes can be made to any settings on the User Menu. These changes however will only remain in effect until the program changes to the next time zone. To make changes permanent, settings must be changed in the program from the Program Menu. Access the Program Menu by holding down the left arrow for 5 seconds until "PRO" is displayed. Arrow down to select programming and arrow left to select the program to edit. Use the down arrow to step through the options and make changes as desired. Continue to press the down arrow until Stor is displayed. Press OK or down to keep or store the changes.

Q. How do I undo a change that I made to a program in the Program Menu?

A. Changes to programs cannot be undone. The programs can however be reset to the factory default settings. This must be done on the Factory Menu. Access to the Factory Menu is attained through the Diagnostics Menu. Press and hold the right arrow for 5 seconds until "DIAG" is displayed. From the "DIAG" display press and hold the up and down simultaneously for 10 seconds until "FACT" is displayed. Use the down arrow to select "DEFn" on the display then use the right arrow to select "DEFP". Press "OK" to reset. The control display will go blank then blink as confirmation.

Q. My air curtain won't turn on?

A. Check the AM/PM setting on the Start and Stop times or the clock (considering the AM indicator light when setting values). Note: set the start time and stop time to the exact time for the unit to be active full time. Check to see if a program is active that may have different start/stop times than those expected.

Q. My building has a Building Management System, can the Intelliswitch work with a BMS?

A. The Intelliswitch can be controlled by a Building Management System (BMS) but currently does not have the ability to communicate with them. Dry contacts on the BMS may be used to control the unit activation through the door switch connections (blue wires 9 & 10) and the heat activation through the remote thermostat connections (orange wires 6 & 7). Consult factory.

X. TROUBLESHOOTING

SYMPTOMS	CAUSE	REMEDY
NO AIR	<ul style="list-style-type: none"> Power supply line open (no power) Fuse blown/circuit breaker tripped Motor overload tripped 	<ul style="list-style-type: none"> Check power source, check method of control in ON position Replace fuse(s)/reset breaker Internally protected motor - should reset automatically after cool-down, if not, replace motor. Replace switch
	MOTOR RUNNING/FANS ARE NOT ROTATING	
	<ul style="list-style-type: none"> Broken or damaged flexible hub Shaft rotating inside fan 	<ul style="list-style-type: none"> Replace fan sleeve/reengage coupling Tighten set screws/tighten fan on shaft
MINIMUM AIR	ELECTRICAL CONTROLS NOT FUNCTIONING WHEN DOOR IS OPEN	
	<ul style="list-style-type: none"> Selector switch is in off position Door limit switch not operating 	<ul style="list-style-type: none"> Turn switch to "ON" position Repair or replace limit switch
AIR IS NOT HITTING FLOOR	<ul style="list-style-type: none"> Air directional discharge vanes mis-adjusted Inadequate intake clearance 	<ul style="list-style-type: none"> Adjust vanes to proper position, see instructions Move air curtain or remove obstruction Provide adequate space for air curtain Improper voltage Free fan from housing Clean and vacuum fan wheels Check fans for blade curve toward discharge
	<ul style="list-style-type: none"> Blower motor operates below speed Fan rubbing against housing Fan wheels clogged with dirt Fan in backwards 	
UNEVEN AIR	<ul style="list-style-type: none"> Air stream too weak Air steam hits obstruction Negative pressure 	<ul style="list-style-type: none"> Adjust nozzle to proper position, adjust motor speed; see installation instructions Remove obstruction or reposition air curtain (move out 3/8" for every 1" up from the door) Relieve negative pressure by providing makeup air
	<ul style="list-style-type: none"> Shaft rotating inside fan One motor not operating 	<ul style="list-style-type: none"> Tighten set screws Repair or replace motor
EXCESSIVE AIR MOVEMENT AT DOORWAY	<ul style="list-style-type: none"> Nozzle not angled out far enough Unit too powerful Air movement too cold Pushing air outside building 	<ul style="list-style-type: none"> Adjust nozzle angle to outside Adjust motor speed Add auxiliary heat to overcome wind chill factor Adjust discharge angle back into building, adjust motor speed
	SEE AIR IS NOT HITTING FLOOR SYMPTOMS	
ELECTRICALLY HEATED MODELS		
NO HEAT	<ul style="list-style-type: none"> Switch turned to "ON" position Thermostat not set properly Coils burned out due to lack of air Automatic reset thermal cutout failed in open position Manual reset thermal cutout tripped (if supplied) 	<ul style="list-style-type: none"> Replace switch or check wiring Change thermostat setting Correct airflow problem; replace coils Replace automatic thermal cutout Reset manual thermal cutout
	<ul style="list-style-type: none"> Thermostat in wrong location - thermostat too close to discharge Improper voltage Thermostat not set properly Low entering air temperature 	<ul style="list-style-type: none"> Move thermostat away from air stream Supply proper voltage Change temperature setting Based on unit temperature rise, reduce speed
MINIMAL HEAT	<ul style="list-style-type: none"> Incorrect speed range Thermostat in wrong location Thermostat not set properly Insufficient air over coil Improper voltage 	<ul style="list-style-type: none"> Set dip switch to electric heated speed range Move the thermostat closer to air stream Change temperature setting Remove restriction on intake Supply proper voltage
STEAM/HOT WATER HEATED UNITS		
EXCESSIVE HEAT	<ul style="list-style-type: none"> Too high steam/hot water pressure Inadequate air flow, fins plugged up, dirty coils 	<ul style="list-style-type: none"> Reduce steam pressure/hot water flow Clean intake and coils
	<ul style="list-style-type: none"> Insufficient removal of condensation (steam) Not enough steam pressure/water temperature too low Intake air below design temperature 	<ul style="list-style-type: none"> Increase trap size Raise pressure for steam/increase water flow Increase steam pressure/increase water flow
MINIMAL HEAT		

XI. APPENDIX

A. Serial Network Connection (previously Master/Slave Connection)

NOTE: ONLY AIR CURTAINS FROM THE SAME SERIES CAN BE NETWORKED TOGETHER. IF UNITS FROM DIFFERENT SERIES ARE NETWORKED OR ARE INCOMPATIBLE, AN ER61 WILL DISPLAY EVERY TIME A COMMAND IS ENTERED.

Serial Network Connection Operation

For Serial Network Connection a serial cable connection must be made between all Intelliswitch™ controls of each air curtain to be linked. Once air curtains are linked all Menu settings made through any air curtain display or remote control will transfer to all other linked air curtain. Parameter changes made on any linked air curtain will update all other boards “live” upon menu selections.

1. All air curtains equipped with an Intelliswitch and the Serial Communication Option have two RJ11 connectors (telephone plug) located in the wiring compartment. Serial cable(s) with the corresponding RJ11 socket (telephone jack) on each end are shipped separately.
2. Once the air curtains are installed, connect all units that are to be networked together using the serial cable(s) and either of the two RJ11 connectors in each wiring compartment. For example, two units networked together require one cable and leaves an unused connector in each wiring compartment. Three units networked together requires two serial cables, leaves two units with one connector unused in each wiring compartment and one unit with both connectors used.
3. A wiring diagram is included in the wiring compartment of each air curtain and illustrates the provision where the serial cable is connected to network additional air curtains.
4. Once all serial cables are connected and all air curtains have power the units can be programmed from any handheld remote or air curtain display on the network. All program settings are included in the installation instructions shipped with the air curtain.
5. If the air curtains were purchased with the WiFi option, when connected to the local WiFi network they can be programmed from a smart phone using the Berner app.

Serial Network Connection - Settings

When units with the Intelliswitch™ are operated in a network there are three options available under the Programming Menu that manage how they interact with each other.

- Door Switch (door)
- Thermostat (temp)
- Stand By (Stby)

Each option can be set to “ind” or “ALL”.

“ind” = the option only is activated on this unit or independent of the other units

“ALL” = the option activates ALL of the units connected on the network

1. To access the Serial Network Connection hold the left arrow for 5 seconds and “Pro” will display
2. Use the left/right arrows to locate the desired option (door/temp/Stby)
3. When located, use the down arrow to enter into that setting.
4. Use the left/right arrow to change the setting between “ind” and “ALL”

EXAMPLE: Stand By function

If set to independent, when STOP is pressed only the unit where STOP is pressed will stop. If set to ALL, all of the connected units set to ALL will stop.

EXAMPLE: Door Switch function

If set to independent, the door switch connected to a unit will only activate that unit. If set to ALL, all of the connected units set to ALL will activate.

B. Remote Mounted Display Faceplate -

for operation of the Intelliswitch™ through a remote mounted display faceplate.

NOTE: Maximum mounting distance between the Display Faceplate and the unit is 20’. The unit MUST be factory ordered with the remote mounted faceplate option.

When the remote faceplate option is ordered from the factory the air curtain comes equipped with the blank faceplate and 20’ ribbon attached. The Display Faceplate is shipped loose ready for field installation.

1. Locate the male end of the 14-conductor ribbon cable in the wiring tray and run to the remote display location. The cable is minimum CL2 rated and should not need to be in conduit.
2. Connect the ribbon cable to the 14-pin socket with red stripe positioned on the top left when facing the front of the display board.
3. Mount remote faceplate to the wall.
4. Reinstall the wiring tray cover.

C. Infra-red Remote Control

The handheld infra-red remote control buttons, layout and operation are the same as that on the Intelliswitch™ air curtain display (including multiple button presses) with one exception, the Lock Button.

There is no need for multi-button press and hold for lock/unlock activation. The Lock Button will lock/unlock display in one press.

The Infra-red Remote Control has a range of 15 feet.

PAGE INTENTIONALLY LEFT BLANK

XII. WARRANTY

Berner International ("The Company") warrants all new equipment to be free of defects in workmanship and material for a period of five years (5 years) on unheated models and two years (2 years) on heated models from the original date of shipment, provided the equipment has been properly cared for, installed and operated in accordance with the limits specified on the nameplate and The Company's instructions.

The Company will correct by repair or replacement, at its option and expense, any proven defects in said apparatus, subject to the above conditions, provided that immediate written notice of such defects is given to The Company. The warranty does not include any labor incurred for the removal or installation of defective part(s). The Company reserves the right to inspect, or have inspected by a qualified representative, any apparatus at the place of installation before authorizing repair or replacement. Repair or replacement will be made F.O.B. factory with any applicable transportation charges to be borne by the customer. Merchandise not of The Company's manufacture supplied in piece, or in component assemblies, is not covered by the above warranty, but The Company will give the customer the benefit of any adjustment as made with the Manufacturer.

This warranty is void if the apparatus has been tampered with in any way or shows evidence of misuse.

The Company will not assume any expense or liability for repairs made outside its factory without proper written consent from its service manager, nor for any transportation charges on apparatus returned to the factory without written authorization by The Company.

Nothing in the above warranty provisions, however, shall impose any liability or obligation of any type, nature or description upon Berner International if Berner has not received payment in full for the apparatus in question.

THERE ARE NO WARRANTIES WHICH EXTEND BEYOND THE DESCRIPTION ON THE FACE HERE OF INCLUDING THE IMPLIED WARRANTY OF MERCHANTABILITY AND FITNESS FOR A PARTICULAR PURPOSE.

LIMITATION OF DAMAGES

Notwithstanding anything to the contrary above, customer's exclusive remedy for any and all losses or damages resulting from the sale of The Company's equipment under this agreement, including but not limited to, any allegations of breach of warranty, breach of contract, negligence or strict liability, shall be limited, at The Company's option, to either the return of the purchase price or the replacement of the particular equipment for which a claim is made and proved. In no event shall The Company be liable for any special, consequential, incidental or indirect losses or damages from the sale of The Company's equipment under this agreement.

SERIAL NUMBER	MODEL NUMBER	DATE PURCHASED
---------------	--------------	----------------



Saving energy and creating healthy, comfortable environments

BERNER INTERNATIONAL
New Castle, Pennsylvania

724-658-3551 • 1-800-245-4455 • www.Berner.com

Berner reserves the right to alter specifications without prior notice.