



MARSHALL ENGINEERED PRODUCTS CO.

FORM 1506G

STEAM SPECIALTIES

Thermostatic Trap, High Pressure, Type TH

APPLICATION

The MEPCO Thermostatic Trap, Type TH, operates efficiently with pressures of 5 to 125 lbs. and is applicable to all types of high pressure steam systems and steam process equipment such as sterilizers, coffee urns, pipe coils, etc. Its purpose is to efficiently drain water and vent air from steam equipment and to prevent the flow of steam into return piping. MEPCO High Pressure Trap is manufactured in three (3) sizes for handling capacities of 125 to 4,500 lbs. of condensate per hour.

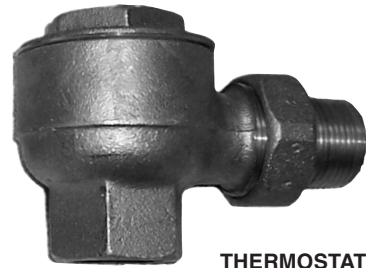

THERMOSTATIC TRAP
NO. TH2A, TH3A AP TRAP



THERMOSTATIC TRAP
NO. TH1A SW TRAP

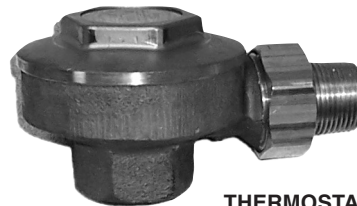

THERMOSTATIC TRAP
NO. TH1A AP TRAP

FEATURES

1. Simple, rugged construction - The trap consists of a cast brass body and cover, replaceable stainless steel valve seat and a thermostatic expansion disc made of stainless steel. All working parts are made of non-corrosive metals especially adapted for high pressure service.

2. Sensitive thermostatic action - Sealing the thermostatic disc under high vacuum assures sensitive and positive response to temperature and pressure over trap's entire operating range. Disc corrugations are shaped to reduce hinge action at the rim of the disc and distribute disc motion.

3. Minimum wear on working parts - The valve and seat are of special long-wearing, heat treated stainless steel. The spherical valve is swiveled to assure its seating tightly. This swivel joint prevents localized stresses on the disc and also prolongs the life of the valve and seat by preventing wear in any one spot.

4. Freedom from clogging - Sharp edge of seat and spherical shape of valve permits intimate contact between the two and

leaves little area for depositing of incrustants. Large valve opening permits easy passage of water and dirt, thereby ridding trap of foreign matter which could cause clogging.

5. Thorough tests - In addition to tests made of the completed trap, each thermostatic disc is checked by an automatic leak detector. Each thermostatic disc must pass a test which will detect a leak so small that in a year's time less than 1/100 of an ounce of thermostatic fluid could escape. All traps are 100% test operated before leaving the factory.

6. Minimum maintenance - Permanent adjustment for correct operation is built into each MEPCO trap. Stop shoulder in trap cover permits disc assembly to be screwed in a predetermined distance. This distance provides the proper amount of clearance between valve and seat for free drainage of condensate and also enables the valve to seat squarely and tightly when in closed position. If, under unusual conditions, it is necessary to replace a thermostatic element, even then no adjustment is necessary.

OPERATION

Fluid in the thermostatic disc of the trap is partially vaporized by the heat of steam and an internal pressure is developed which overcomes the surrounding steam pressure. This expands the member and carries the valve toward its seat with a positive force. The MEPCO thermostatic trap quickly adjusts itself to a position determined by the temperature and pressure conditions encountered and permits either a continuous or an intermittent flow of water and air from the process equipment being trapped at the rate required for highest heating efficiency.

SELECTION

DEFINITION OF "TEMPERATURE DROP" - Due to the great variation in temperature and pressure encountered in high pressure steam equipment, trap capacities vary according to conditions at the location of each trap. For example, a thermostatic trap at one location may have to handle large volumes of condensate whereas a trap at a different location may have to handle very little. In addition to the volume of condensate, temperature must also be considered. The temperature of the condensate entering the trap as compared to the temperature of the steam in the equipment is generally termed the "temperature drop".

USING "TEMPERATURE DROP" TO DETERMINE TRAP CAPACITY - Under ordinary conditions connections ahead of the trap are short and consequently the temperature drop is small. Under other conditions connections require the condensate to flow through long lengths of piping without contact with steam; then the temperature drop may be large. With a large "temperature drop", a higher trap capacity will result.

The following tables are organized for easy selection of the proper trap according to approximate temperature drop. For capacities based on continuous discharge under average operating conditions (approximately 5 degrees F temperature drop), consult Table No. 1. For special requirements such as government specifications where a temperature drop of 30 to 40 degrees F is expected, use Table 2. (This table is in accordance with the requirements of Specification 45T2B of the Navy department on Class II high pressure thermostatic traps.)

CAPACITIES

CAPACITIES (pounds condensate per hour)

Table No. 1 — Temperature Drop, approx. 5°F.

TRAP NO.	CAPACITY (LBS. CONDENSATE PER HOUR)				
	WORKING PRESSURE (LBS PER SQ. IN.)				
	5	25	35	50	100
TH-1A	125	255	445	560	840
TH-2A	195	565	700	880	1300
TH-3A	290	790	980	1200	1780

Table No. 2 — Temperature Drop, 30° to 40°F.

TRAP NO.	CAPACITY (LBS CONDENSATE PER HOUR)			
	WORKING PRESSURE (LBS PER SQ. IN.)			
	25	35	50	100
TH-1A	1200	1550	1950	2600
TH-2A	1800	2200	2600	3500
TH-3A	2500	2900	3400	4500

DIMENSIONS & WEIGHTS

When ordering specify: (1) Trap Number, column one, (2) Pattern, column three.

DIMENSIONS AND WEIGHTS

TRAP NO.	SIZE CONN.	PAT-TERN	DIMENSIONS					SHPG. WGT. (LBS.)
			A	B	C	D	E	
TH-1A	1/2"	AP	3 1/8"	1 1/8"	2 5/8"	2 1/4"	—	2
TH-1A	1/2"	SW	3 1/4"	1/2"	2 1/2"	2 1/4"	1 1/4"	2 1/2
TH-2A	3/4"	AP	3 1/4"	1 1/16"	3 1/2"	2 1/4"	—	2 1/4
TH-3A	1"	AP	3 1/2"	1 1/4"	3 7/16"	2 1/4"	—	3

WHEN ORDERING OR SPECIFYING, INDICATE:

(1) Trap Number

(2) Pattern

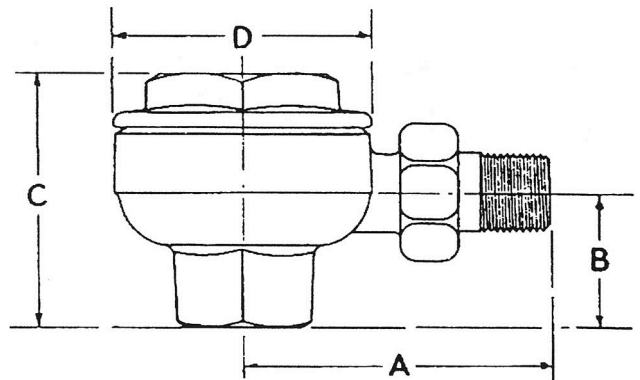

FIGURE 1. TH1A AP TRAP

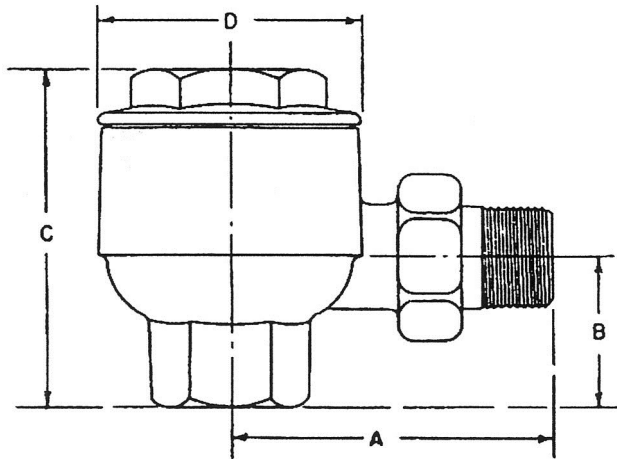

FIGURE 2. TH2A AP TRAP, TH3A AP TRAP

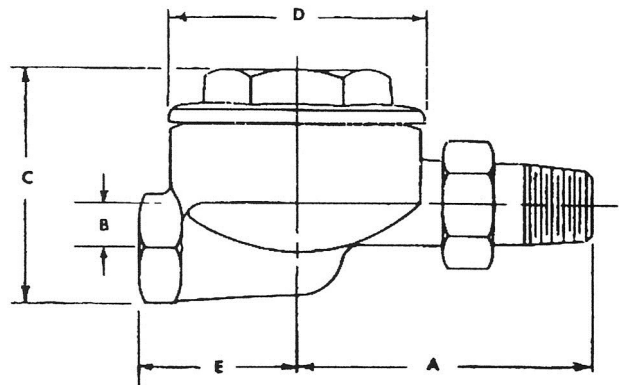

FIGURE 3. TH1A SW TRAP

TYPICAL SPECIFICATIONS

The contractor shall furnish & install as specified in the plans and in accordance with the manufacturer's instructions _____ (size: 1/2", 3/4", or 1") _____ (configurations: TH1A AP, TH2A AP, TH3A AP or TH1A SW) MEPCO Type _____ Model TH1A, TH2A, TH3A High Pressure Trap, which has a capacity rating of _____ LBS/HR. @ PSI differential. The trap body and cover, shall be made of cast brass, replaceable stainless steel valve seat and thermostatic expansion disc made of stainless steel. All other parts shall be made of non-corrosive materials adapted for high pressure service.

MEPCO reserves the right to make changes in specifications and design without notice.



MARSHALL ENGINEERED PRODUCTS CO.

3695 44th Street SE, Grand Rapids, Michigan 49512

Phone 616.971.3420 Fax 616.971.3421 www.mepcollc.com