

Zehnder Carboline Radiant Heating and Cooling Ceiling Panels



Installation, Operation and Maintenance

Heating

Cooling

Fresh Air

Clean Air

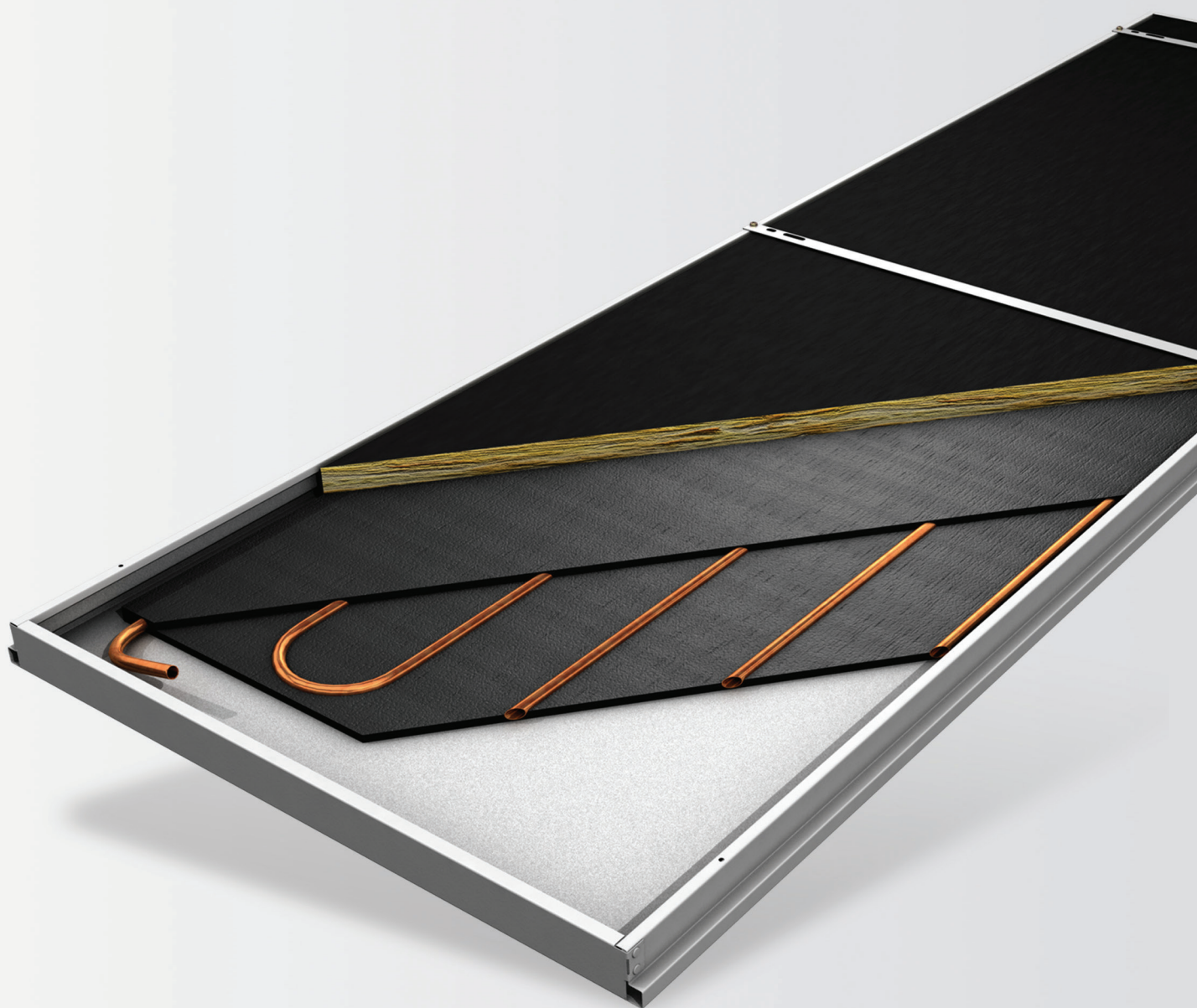

General information	1
Safety considerations	1
Unpacking and preparation	3
Handling and installation	4
Suspension	8
Water system	14
Operation	17
Replacement parts	19

IMPORTANT: Submittal documentation, specific to each project, supersedes the general guidelines contained within this manual.

General information

This installation and start-up instructions literature is for Carboline Radiant Ceiling Panels. Radiant ceiling panels are hydronic units designed for year-round cooling and heating. Your equipment is initially protected under the Zehnder Rittling standard 5-year warranty provided the steps outlined in this manual for initial inspection, installation, periodic

maintenance and normal every day operation of the equipment are followed. This manual should be thoroughly reviewed prior to the installation, start-up or maintenance of the equipment. If any questions arise, please contact your local Zehnder Rittling sales representative or the factory before proceeding any further.

Safety considerations

The installation of Carboline Radiant Ceiling Panels and all associated components, parts and accessories which make up the installation, shall be in accordance with the regulations of all authorities having jurisdiction and must conform to all applicable codes. Only trained and qualified service personnel using good judgment and safe practices should install, repair and/or service air conditioning equipment.

Untrained personnel can perform basic maintenance functions such as cleaning panels. All other operations should be performed by trained service personnel. When working on air conditioning equipment, observe precautions in the literature, tags and labels attached to the equipment and all other safety precautions that may apply.

Improper installation, adjustment, alteration, service, maintenance, or use can cause hazardous conditions which may cause serious personal injury and/or property damage. Consult a qualified installer, service agency, or your sales representative for information or assistance.

The equipment must always be properly supported by rigging and lifting equipment. Any temporary supports used during installation or maintenance must be designed to adequately hold the equipment in place until equipment is permanently fastened and set in its final location. All supports must meet applicable local codes and ordinances.

All fastening devices must be designed to mechanically hold the assembly in place without the ability to loosen or break away due to system operation or vibration.

Gloves should always be worn for protection against heat, sharp edges and all other possible hazards. Safety glasses should always be worn, especially when drilling, cutting or working with chemicals.

Never pressurize equipment beyond specified pressures. Always pressure test with an inert fluid such as water or dry nitrogen to avoid possible damage or injury in the event of a leak or component failure during testing.

Safety considerations

Please follow standard safe practices regarding the handling, installing or servicing of mechanical equipment.

Read these instructions thoroughly and follow all warnings or cautions attached to the equipment. Consult local building codes for special installation requirements.

Understand the signal words: danger, warning and caution.

⚠ DANGER

Identifies the most serious hazards which will result in severe personal injury or death.

⚠ WARNING

Signifies hazards that could result in personal injury or death.

⚠ CAUTION

Used to identify unsafe practices, which would result in minor personal injury or product and property damage.

The manufacturer assumes no responsibility for personal injury or property damage resulting from improper or unsafe practices during the handling, installation, service or operation of the equipment.

The installation of fan coils and all associated components, parts and accessories shall be in accordance with the regulations of all authorities having jurisdiction and must conform to all applicable codes. It is the responsibility of the installing contractor to determine and comply with all applicable codes and regulations.

Receiving

Upon delivery, examine the shipment against the bill of lading to make sure all of the panels have been received and then check each panel carefully for shipping damage. Any damage should be reported to the freight carrier and a claim should be filed with them. Ensure the shipping company makes proper notation of any shortages or damage on all copies of the freight bill. Concealed damage not discovered during unloading must be reported to the shipping company within 15 days of receipt of the shipment.

All panels are shipped F.O.B. factory. Therefore, Zehnder Rittling is not responsible for damage during transit. It is the responsibility of the installing contractor to inspect and verify that the panels shipped were in fact the correct type, length, etc. Any discrepancies should be reported to the local Sales

Representative for immediate resolution prior to unpackaging and installation. The factory should be notified of any warranty repairs required in writing before any corrective action is taken. The factory must be fully informed of the expected costs before the work is begun. Zehnder Rittling is not responsible for any repairs or alterations made by the purchaser without Zehnder Rittling's written consent and will not accept any back charges associated with these repairs or alterations. The return of damaged equipment will not be accepted without written authorization from Zehnder Rittling.

A unit that has received a written Return Goods Authorization will be inspected by Zehnder Rittling upon receipt. Any damage, missing parts, reworking or repackaging resulting from prior installation will constitute just cause for Zehnder Rittling to issue partial credit.

Unpacking and preparation

All panels are carefully inspected at the factory throughout the entire fabrication and assembly processes under Zehnder Rittling's stringent quality assurance program.

Each panel is carefully packaged with a protective film for surface protection during normal handling. It is the sole responsibility of the customer to provide the protection necessary to prevent vandalism and weather deterioration of the equipment. Under no condition should the panels be left unprotected from the elements. If the equipment is not needed immediately at the job site, it should be left in its shipping carton and stored in a clean, dry area of the building or in a warehouse. Do not remove any equipment from its shipping package until it is needed for installation. The equipment is NOT suitable for outdoor installations.

Carefully remove each panel from the container and inspect for hidden damage. Any hidden damage should be recorded and immediately reported to the carrier and a claim should be filed. In the event a claim for shipping damage is filed, the panel shipping container, and all packing must be kept for physical inspection by the freight carrier.

Cap open ends of piping that are stored on a job site. Take special care to prevent foreign materials from entering the piping in areas where painting, dry walling, or spraying of fireproof material, etc., has not yet been completed. Before installing any of the system components, be sure to examine each pipe, fitting and valve, and remove any dirt or foreign material found in or on these components. Some job conditions may require some form of temporary unit covering during construction.

⚠ CAUTION

DO NOT store or install panels in corrosive environments or in locations subject to temperature or humidity extremes (e.g., attics, garages, rooftops, etc.). Corrosive conditions and high temperature or humidity can significantly reduce system performance, reliability and overall service life.

Handling and installation

While all equipment is designed for durability and fabricated with heavy gauge materials and may present a robust appearance, great care must be taken to assure that no undue force is applied to the piping, connection or graphite surface during handling. Gloves should be worn when handling finished, painted panels and should never be set down on unclean, hard surfaces. Failure to follow these instructions may lead to scratching or gouging of the finished surface.

Although Zehnder Rittling does not become involved with the design and selection of support methods and/or components, it should be recognized that unacceptable operating characteristics and/or performance may result from poorly implemented unit support. Additionally, proper clearance must be provided for service and removal of the equipment.

▲ WARNING

Improper mounting could result in the unit falling from its position, causing personal injury or even death.

After mounting the panel, it is then ready for the water service connections. At this time it should be verified that the proper types of services are actually provided to the unit. On those units requiring chilled water and/or hot water, the proper line size and water temperature should be available to the unit.

Handling and installation

Carboline Radiant Ceiling Panels should be transported vertically to prevent damage....

Do not transport panels horizontally. This could result in damage to the panel.



Storage

Carboline Panels must be stored on edge in a graphite-to-graphite and face-to-face alternating pattern..

Improper storage configuration could result in damage to the panel.



Protective film

Carboline Panels are shipped from the factory with a protective film applied to protect the painted surface of the panels. Make sure to remove the protective film from all adjoining edges of the panel or panels placed against the wall before installation. Film must be completely removed from the panel before start-up. Clean, soft gloves should be worn at all times when handling the panels to avoid surface damage.

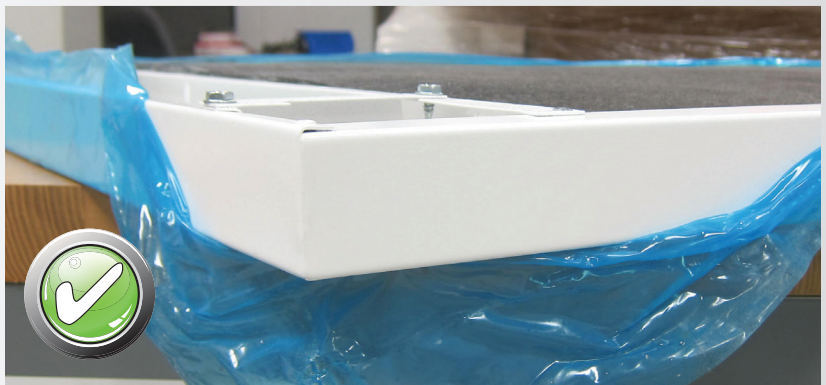
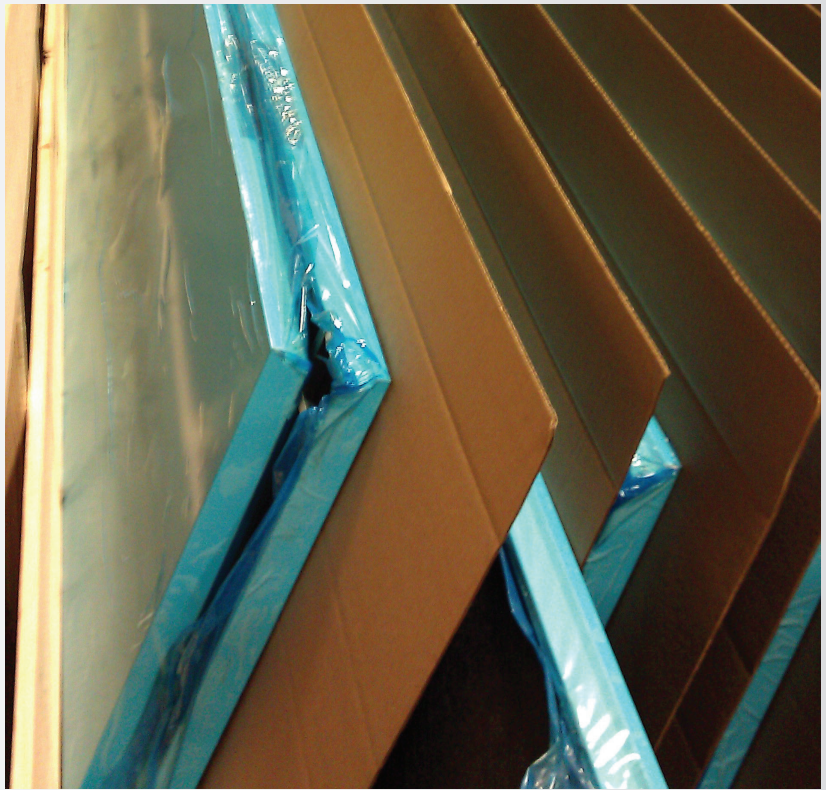

Suspension

Zehnder Carboline is installed, as standard, into a ceiling grid with the option of attaching the panels directly to the ceiling.

Based upon the size of the panel, there are a number of suspension points available for use. Suspension points reside on the fixing bars located near the panel ends on all panels and on additional fixing bars installed on panels over 48" in length. The oblong holes located on the lip of the panel between the fixing bars cannot be used as suspension points.

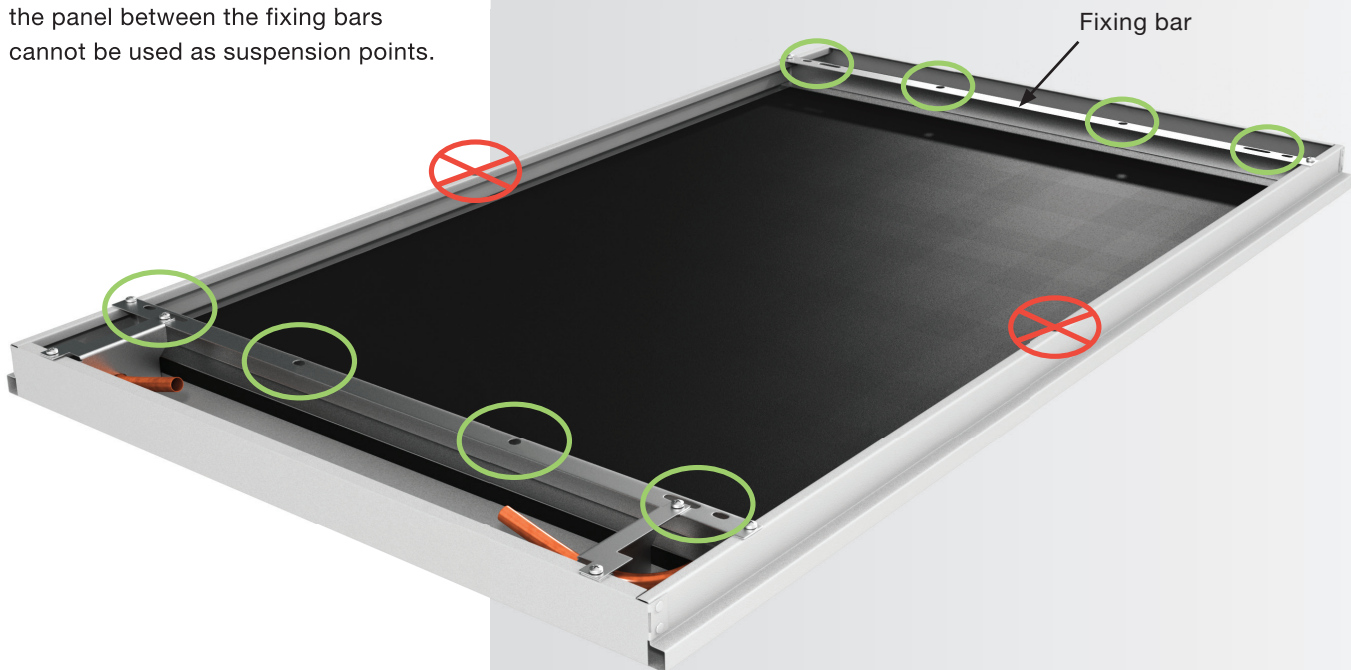

Suspension points and weights

Carboline panels are offered in five nominal standard sizes.

Size	Suspension points	Weight (lbs.)
24" x 24"	4	10.98
24" x 48"	4	19.86
24" x 72"	6	29.43
24" x 96"	6	38.29
24" x 120"	8	45.37

Weight of panel includes insulation and water

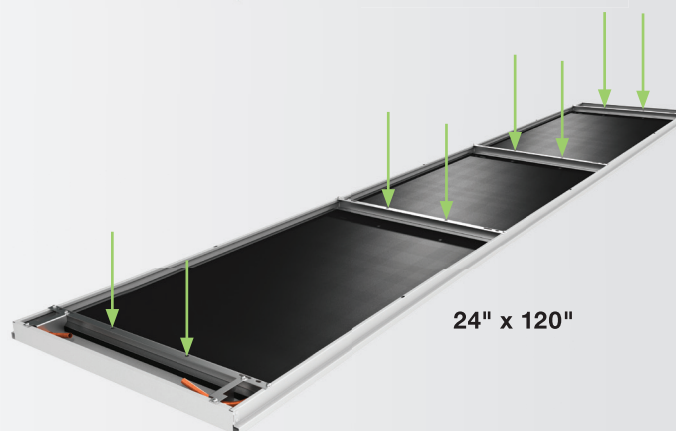
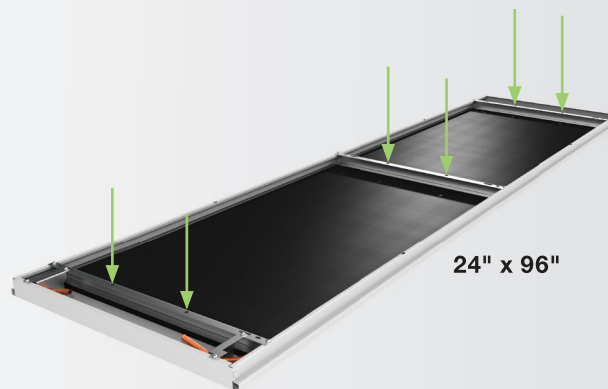
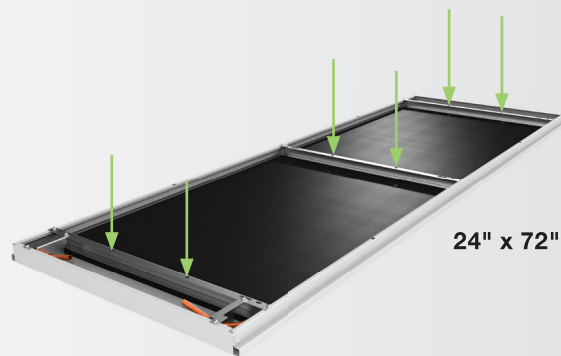
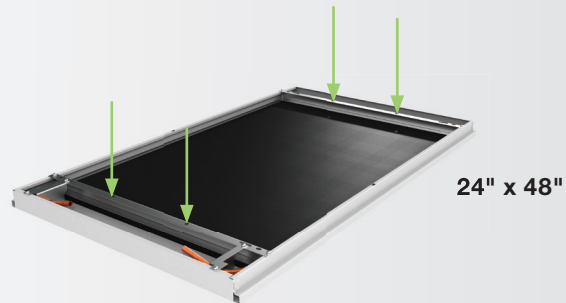
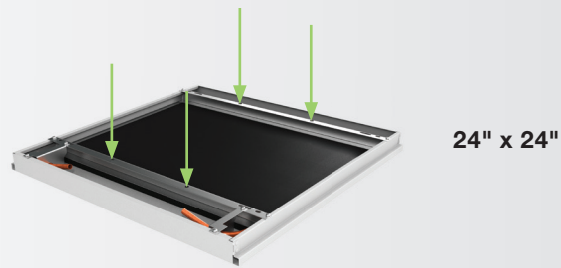

Panel connections

Chains and fixing clips

Clips can be attached to the fixing bar in the corner of the panels or simply clipped into the lip on the side of the panel. The individual clips can be moved along the side of the panel and leveling adjusted to the conditions in the building.

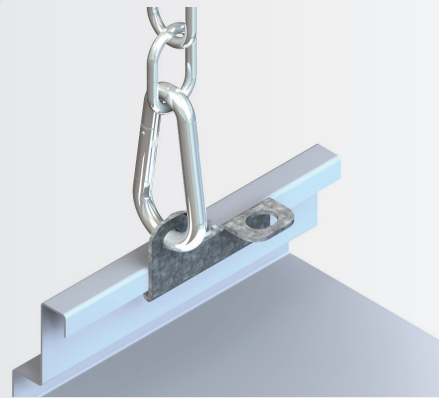

Panel connections

Wire rope

Wire rope is provided with gripple cable hangers. The .05" thick wire ropes used to secure the Carboline free hanging version make for seamless integration in any room. Leveling the panel with the fine adjustment setting means that the wire rope can be set to the exact installation height.

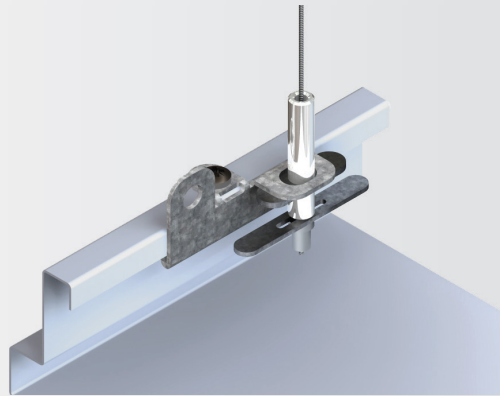

Y-configured wire rope

Y-configured wire rope is used in conjunction with T-bar grid systems.



Level modules

For proper function, Carboline Panels must be leveled both in the longitudinal direction and in the traverse direction.



Expansion bracket release

For panel sizes 24" x 72", 24" x 96" and 24" x 120" only.

After installation of the modules, open each screw A between 1/4 and 1/2 turn. Do NOT open screw B.

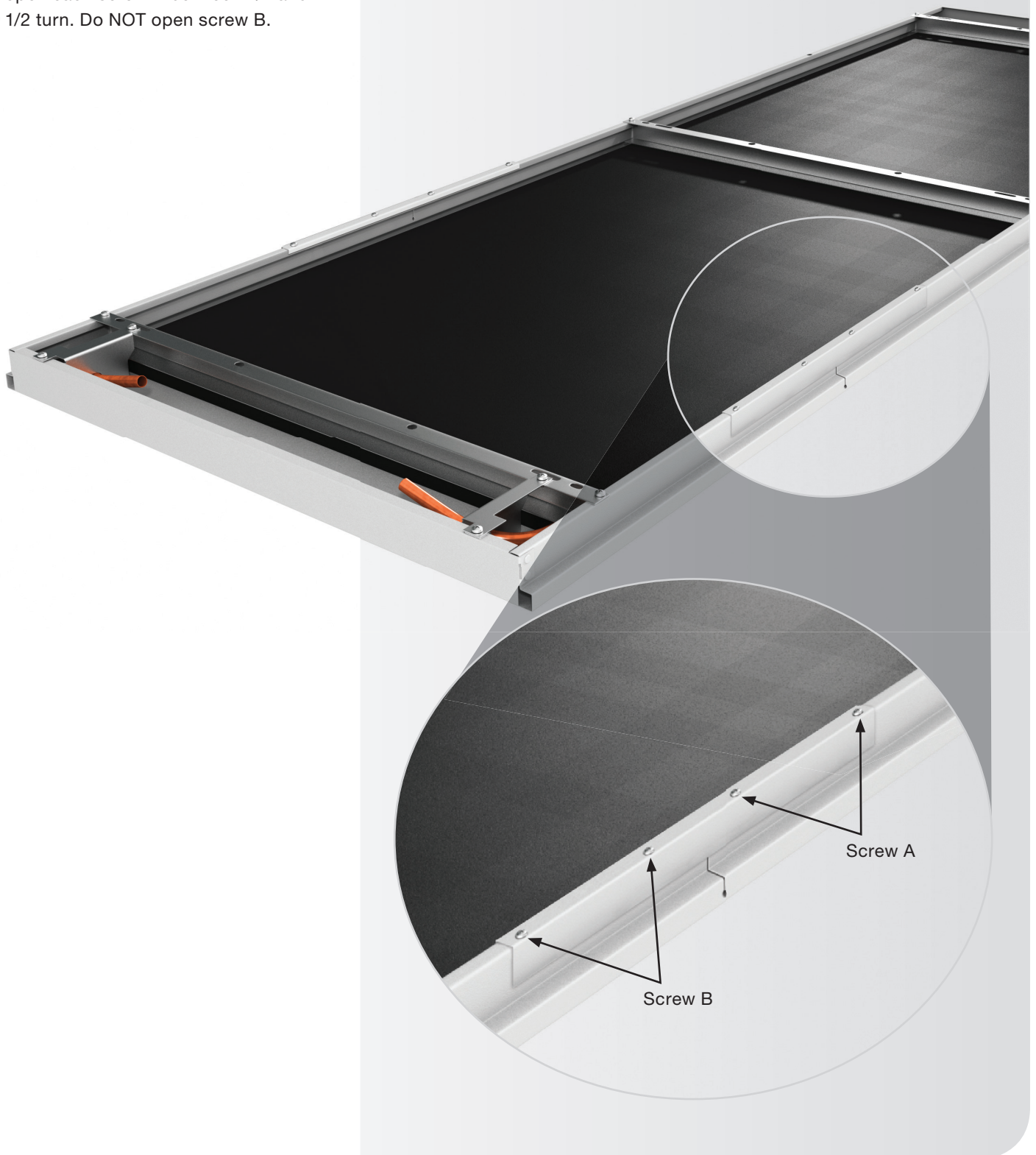

Cooling/heating system

Prior to the water system start-up and balancing, the chilled/hot water system should be thoroughly flushed to clean out dirt and debris which may have accumulated in the piping during construction. During this procedure, all panel service valves must be in the closed position. This will prevent any foreign material from entering the panel's piping and clogging valves and metering devices. Strainers should be installed in the piping mains to prevent this material from entering the units during normal operation.

During system filling, air venting from the panel is accomplished through the main system air vents.

⚠ CAUTION

Inspect the entire system for potential air traps and independently vent those areas as required. In addition, some systems may require repeated venting over time to fully eliminate air in the system.

Water system balancing

A complete knowledge of the hydronic system, including its components and controls, is essential to proper water system balancing and should only be completed by a qualified expert. The system must be complete, and all components must be in operating condition before beginning the water system balancing procedures.

Each hydronic system has different operating conditions depending on the devices and controls installed for the particular application. The actual balancing technique may vary from one system to another.

After the proper system operation is established, the appropriate operating conditions such as water temperatures, flow rates and pressure drops should be recorded for future reference.

Before and during water system balancing, conditions may exist due to incorrect system pressures which may result in noticeable water noise or undesired valve operation. After the entire system is balanced, these conditions will not exist on properly designed systems. If any of these conditions persist, recheck the system for air that may not have been properly vented during start-up.

Water treatment

Proper water treatment is a specialized industry and therefore it is recommended to consult an expert in this field to analyze the water for compliance with the water quality parameters listed below and to specify the appropriate water treatment program. The expert may recommend rust inhibitors, scaling preventative, antimicrobial growth agents or algae preventatives. Anti-freeze solutions, glycols, may also be used to lower the freezing point.

All Zehnder Rittling panels are constructed with copper tubes. It is the end user's responsibility to ensure that any of the water delivery components are compatible with the treated water.

Failure to provide proper water quality will void the Carboline panel's warranty.

Water content	Required concentration
Sulphate	< 200 ppm
pH	7.0 – 8.5
Chlorides	< 200 ppm
Nitrate	< 100 ppm
Iron	< 4.5 mg/L
Ammonia	< 2.0 mg/L
Manganese	< 0.1 mg/L
Dissolved solids	< 1000 mg/L
Calcium carbonate hardness	300 – 500 ppm
Calcium carbonate alkalinity	300 – 500 ppm
Particulate quantity	< 10 ppm
Particulate size	800 micron max

Copper tubes and brackets

- Do not remove the copper tube brackets.
- Do not braze/solder tubes, this will void the warranty.

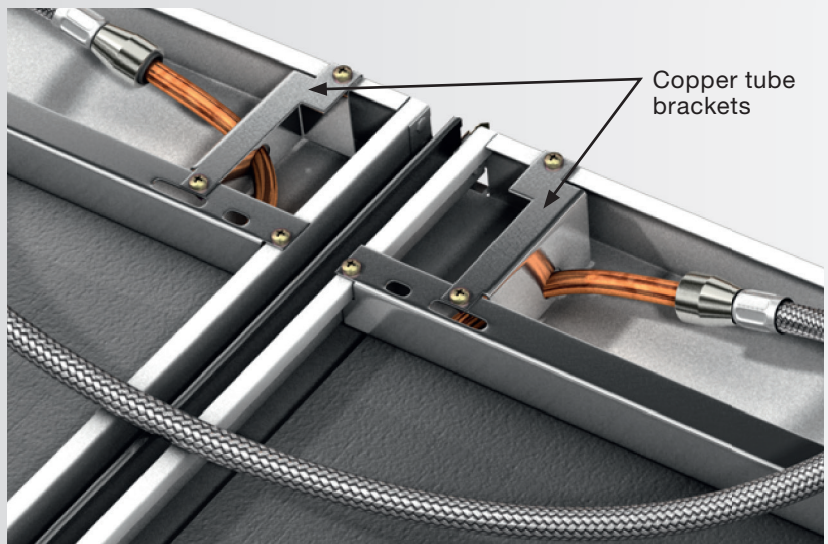

Module connections

- Connect the modules with push-to-connect fittings and flexible hoses.

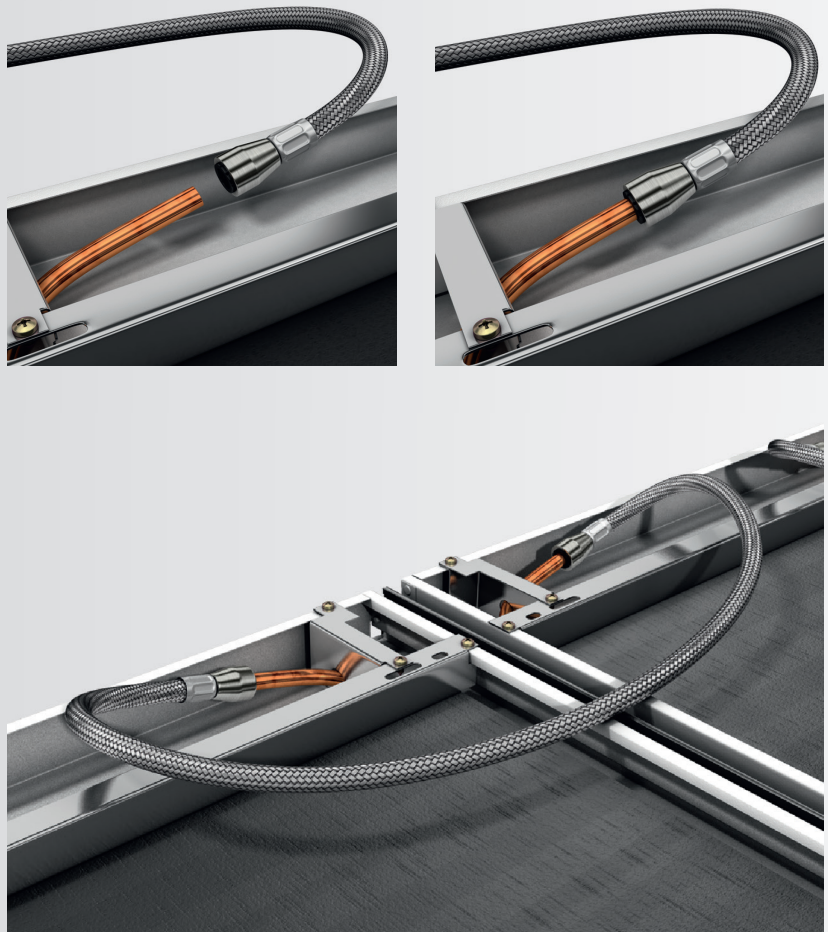

Operation

- Maximum temperature: 185 °F
- Minimum temperature: 40 °F
- Maximum pressure: 145 psi
- Ensure air is removed from system at start-up and during operation.

Maintenance

- Clean with soft cloth and mild detergent as needed.



Chilled/hot water connections

Submittals and product literature detailing unit operation, controls and connections should be thoroughly reviewed before beginning the connection of the various cooling and/or heating mediums to the panels.

All shipped loose valves and hoses should be installed as required and all service valves should be checked for proper operation.

After the module connections are completed, the system should be tested for leaks. Since some components are not designed to hold pressure with a gas, hydronic systems should be tested with water. Test pressure must not exceed 200 psig. Pressure testing should be completed prior to sheet rocking, finished floors, painting, caulking, etc.

⚠ CAUTION

All panels must be protected from freezing after initial filling with water. Even if the system is drained, panels may still hold enough water to cause damage when exposed to temperatures below freezing.

In the event that leaking or defective components are discovered, the Zehnder Rittling Sales Representative must be notified before any repairs are attempted. All leaks should be repaired before proceeding with the installation.

After system integrity has been established, the panels should be insulated in accordance with the project specifications. This is the responsibility of the installing or the insulation contractor if not already purchased and provided by Zehnder Rittling. Zehnder Rittling will not accept any charges associated with re-insulating panels if the installing contractor failed to establish system integrity prior to insulating.

Replacement parts

Factory replacement parts should be used wherever possible to maintain unit performance and its normal operating characteristics.

Replacement parts may be purchased through the local Zehnder Rittling Sales Representative.

Contact the local Sales representative or factory before attempting any unit modifications. Any modifications not authorized by the factory could result in personnel injury, damage to the unit, and will void the manufacturer's warranty.

When ordering parts, the following information should be supplied to ensure proper part identification:

- Complete unit model number
- Complete part description including any identifying numbers on the part

On warranty replacements, it is often necessary to return the faulty component to receive credit. Contact the local Sales Representative who will get authorization from the factory including an RGA (Returned Goods Authorization) to be used when sending components back for inspection. Any returned components sent back to the factory without the proper RGA attached will cancel any outstanding credit.

Equipment start-up checklist

Receiving and inspection

- Panel received undamaged
- Panel received complete as ordered

Handling and installation

- Panel mounted level and square
- Proper access is provided for panel and accessories
- Proper chilled/hot water line sizes to panel
- All services to panel in code compliance
- Panel protected from dirt and foreign matter

Cooling/heating connections

- Connect field piping to panel
- Pressure test all piping for leaks

Unit start-up

- General visual inspection and system inspection
- Close all panel isolation valves
- Flush water systems
- After system has been flushed, ensure all isolation valves are open

