

Rittling Cabinet Unit Heaters

Catalog





Zehnder decorative radiators



Heating and cooling ceiling systems



Comfortable indoor ventilation



Clean air solutions

zehnder

always the
best climate

Always the best climate for

IMPROVED QUALITY OF LIFE

With Zehnder, you will find the perfect climate for any space.

www.zehnder-systems.com

Versatility, style and cooling/heating efficiency

Engineering excellence and contemporary design

With more than 50 years experience in the design and manufacture of hydronic heating and cooling systems, Zehnder Rittling understands your need for efficient heating/cooling equipment that will complement the décor. Rittling Cabinet Unit Heaters offer the latest in attractive design and are engineered to provide years of reliable operation and energy-efficient comfort. All units run quietly and feature individual controls.

Meet specific heating and cooling requirements

Rittling Cabinet Unit Heaters are available in a wide range of models and air flow arrangements to satisfy the demands of your heating and cooling specifications.

Uniform appearance

All Rittling Cabinet Unit Heaters have the same height and the same depth per model—only the length varies for different size units. This provides a consistent, attractive appearance when an installation calls for units of various lengths.

Flexible safe installation

Rittling Cabinet Unit Heaters are available in floor, wall and ceiling-mounted models. A black pedestal base on floor models provides clearance for most mopboards. The base can be repainted in the field if needed. All Rittling ceiling models come with a hinged front cover and safety chain(s) for simple and safe maintenance.

Easy to operate

Rittling Cabinet Unit Heaters feature three-speed control settings and optional thermostats. The user has fingertip control over fan speed and room temperature. (Note: on ceiling units, speed switch assembly is shipped loose.)

Durable

Front panels and tops are constructed of 16-gauge cold rolled steel to withstand impact and rugged treatment. Exterior cabinet surfaces feature an epoxy powder coating to provide a durable, attractive finish.



Quiet operation meets heating efficiency

With more than 60 years experience in the design and manufacture of hydronic heating and cooling systems, Zehnder Rittling understands your need for efficient heating equipment that will complement the décor. Rittling Cabinet Unit Heaters offer the latest in attractive design and are engineered to provide years of reliable operation and energy-efficient comfort.

Rittling Cabinet Unit Heaters run quietly in the background and feature individual controls for optimum management of the indoor environment in offices, apartments, hotels, etc. Our Cabinet Unit Heaters are built to withstand everyday wear and tear with panel construction that also maintains crisp straight lines.

Each unit is designed and built to the same height and depth, providing a consistent appearance when installations call for units of varying lengths.

Rittling Cabinet Unit Heaters are available in a wide range of floor, wall and ceiling models and air flow arrangements to satisfy the demands of your heating specifications. In addition to this, Zehnder Rittling experts are able to help with complex specification plans through our competent sales team. "If you can draw it, we can build it."

Models and arrangements	4
Features	6
Options and accessories	7
AHRI ratings	9
Electrical data	10
Valve packages	11
Control packages	16
Dimensions and data	19
Mechanical specifications	24
Warranty	27

Models and airflow arrangements

Wall models



RW: Wall
RW-260 shown
RW-270 and RW-280 available

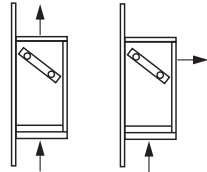

RW-260 RW-270

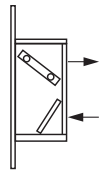

RW-280



RRWI: Wall, partially recessed, inverted flow
RRWI-330 shown

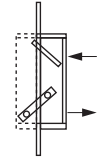

RRWI-330



RWI: Wall, inverted flow
RWI-290 shown
RWI-300 and RWI-310 available

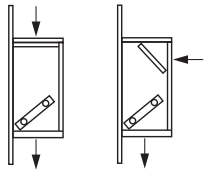

RWI-290 RWI-300

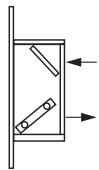

RWI-310



RFRW: Wall, fully recessed
RFRW-340 shown

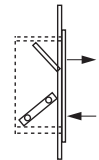

RFRW-340



RRW: Wall, partially recessed
RRW-320 shown

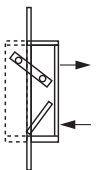

RRW-320



RFRWI: Wall, fully recessed, inverted flow
RFRWI-350 shown

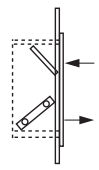

RFRWI-350

Models and airflow arrangements

Floor models



RF: Floor
RF-200 shown, RF-220 available

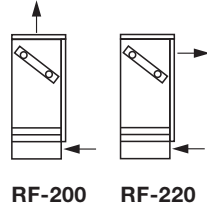

RFI: Floor, inverted flow
RFI-240 shown, RFI-250 available

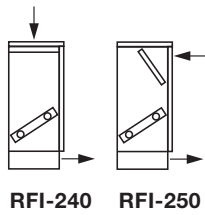

RS: Floor, sloped
RS-200 shown

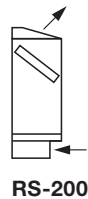

RSI: Floor, sloped, inverted flow
RSI-240 shown

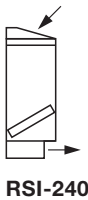

Ceiling models



RC: Ceiling
RC-360 shown
RC-370, RC-380, RC-390 and
RC-400 available

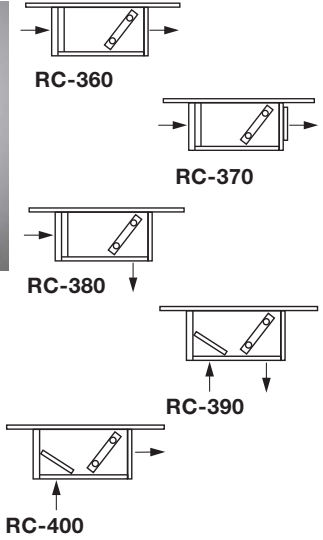

RRC: Ceiling, partially recessed
RRC-440 shown

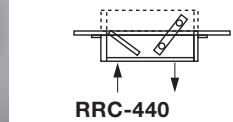

RFRC: Ceiling, fully recessed
RFRC-420 shown

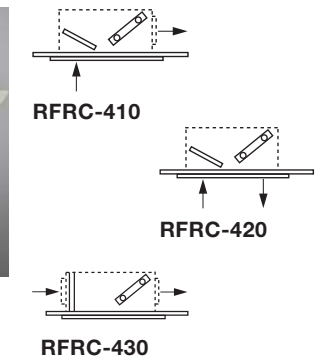

Features

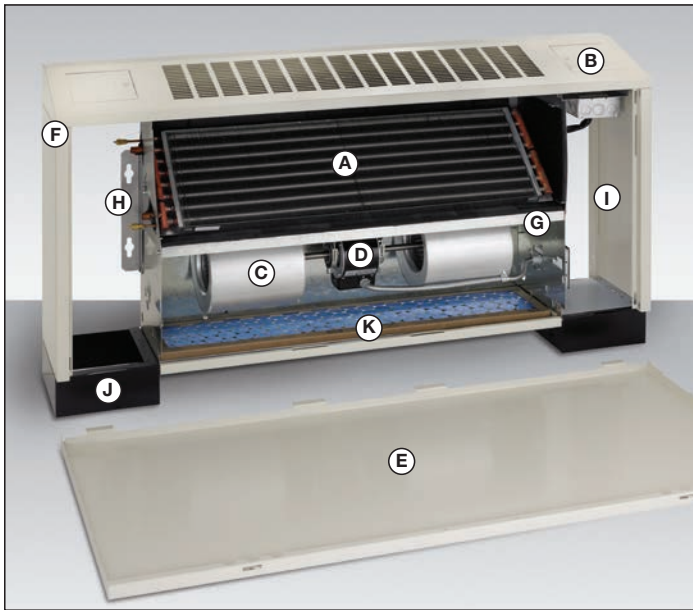

A: Coils

1 row standard

- Sturdy, mechanically-bonded copper/aluminum coil with 12 fins per inch and 1/2" nominal tubes
- High BTU/hr capacity with low noise
- Coil assemblies tested for a maximum of 300 psig working pressure
- Manual air vent

High capacity coil

- Hot water coil provides higher capacity when required load exceeds standard coil for a given size
- Durable construction with double depth fins and two rows of tube
- Coil assemblies tested for a maximum of 300 psig working pressure
- Manual air vent

B: Speed control/access door

- Hidden from view, three-speed fan switch allows speed selection for comfort control
- Easy opening access doors feature cam lock fasteners and are available with optional tamper-resistant fasteners (Speed control switch is not mounted on ceiling units, but shipped loose)

C: Blower fan housing

- Provides excellent CFM output per unit size

- Operating ampere ranges from 0.3 amps (125 CFM) to 2.26 amps (1180 CFM), 120 volts
- Quiet blower assembly made with galvanized steel for strength and durability

D: Motor

- Motors are permanent split capacitor for extended, reliable motor life
- Multispeed motors achieve a wide range of CFM delivered

E: Cabinet

- Heavy duty 16-gauge front panel (14-gauge available) protects against impact. Tamper-resistant, flush-mounted quarter-turn fasteners included as standard. (All exposed or recessed ceiling models come equipped with a hinged front panel and safety chain[s] for safe and easy maintenance.)

F: Finish

- Attractive ivory epoxy powder coating is standard
- Additional colors are optionally available. Please furnish a color chip for custom color.

G: Blower deck

- Blower deck enhances strength and stability, with easy accessibility
- Removable for ease of maintenance

H: Internal support bracket

- All wall and ceiling units are equipped with internal mounting brackets for secure attachment to wall or ceiling

I: Access area

- Large rough-in area at each end of the unit provides ample room for plumbing and electric controls
- Removable front panel provides access to valve/piping connection (standard on left side) and electrical wiring area (standard on right side)

J: Leveling legs

- Four (4) optional leveling legs per unit allow for pitch adjustment and mounting on uneven surfaces

K: Filter

- 1" disposable spun glass media slides easily into locating tabs
- Easily removed from floor models, with the standard open inlet without front panel removal

Options and accessory equipment

Factory assembled

Coils

High capacity 2 row coil

- Provides high heat output in limited space requirements. These coils are available in hot water applications only.

Automatic air vent

- In lieu of manual air vent (hot water only).

Cabinet

Construction

- 14-gauge front panel only and complete 14-gauge cabinet construction available for heavy-duty applications.
- For a finished back panel, contact the factory.

End pockets

- 6" left hand and/or right hand end pocket extensions allow additional room for the mounting of valve packages and piping. Access doors are located in standard position.

Insulated front panel

- Entire front panel is insulated with 1/2" thick fiberglass duct liner for superior thermal protection and noise reduction.

Insulated internal cabinet

- The front panel, blower deck, and chassis coil section are insulated with 1/2" thick fiberglass duct liner for superior thermal protection and noise reduction.
- Contact the factory for 1/2" foil-faced or closed cell insulation.

Color

- All Zehnder Rittling Cabinet Unit Heaters come with an ivory powder paint finish. Additional standard colors are available. Furnish a color chip for custom color.

Security

Limited accessibility for access doors

- Optional Allen key cam lock fasteners are available. Special tools are needed to open doors. Contact the factory regarding Torx head fasteners.

Louvers and grilles

Louvered inlet

- On Models RF and RS: the optional kick space louvered inlet provides appealing, continuous closed floor line and hinders build up of dust, papers, or other material.

Aluminum grille

- Provided in place of standard louver. Heavy-duty bar grille of clear anodized aluminum. Can be painted to match decorator colors.

Double deflection discharge grille

- Aluminum framed grille with adjustable blades in two directions. (RF-200, RS-200, RF-210, RW-260, RC-360, RC-400 models only.)

Architectural bar grille

- Clear anodized aluminum bar grille is optional on all sizes. The rugged aluminum vanes provide a strong lineal appearance preferred in modern office and others areas.
- (May be painted to match Cabinet Unit Heater color.)

Security-perforated grille

- Security-perforated grille is available for installations such as prisons, schools, housing projects or high-traffic areas. Perforated holes provide enough open area for efficient output while keeping the unit tamper-resistant. Contact the factory for pricing.

Leveling legs

- Leveling legs are available to adjust pitch on uneven floors.

Motors

Alternate voltage

- 208V, 230V and 277V supply voltage converted to 120V/60/1 by transformer.

High static motor

- 1550 RPM, 120V/60/1 permanent split capacitor motor. Standard airflow maintained with external static pressure of up to 0.2" water column.

EC motor

- Electronically commutated motors (ECM).
- High-efficiency, programmable, brushless DC motors that utilize a permanent magnet rotor and built-in inverter.
- Provide low operating cost and ultra-quiet operation.
- Separate 2-10 VDC or three-speed control card is included.

Motor quick connect

- Molex connectors are provided on each motor for ease of removal, located at motor.

Power supply cord

- Heavy-duty grounded plug-in cord conveniently connects unit to standard wall outlet.

Disconnect switch

- Installed on face of electrical junction box. Located in electrical end pocket (15 amp max.).

Motor starter

- 120V/60/1, Manual reset motor starter with toggle switch and thermal overload protection. Unit can only be restarted by resetting toggle switch. Starter comes with an overload protection set at 125% of full load current. Located in electrical end pocket. Contact factory for alternate voltages.

Dampers

0-25% manual outside air damper

- Includes damper, manually adjustable through return air opening. Located in bottom of floor mounted units only (models RF and RS).

0-25% motorized outside air damper

- Operational at 0% or 25% outside air. Furnished with a 120V/60/1 synchronous motor that is wired to the blower to automatically open the damper when the fan starts. When the power is off or interrupted, the damper returns to the closed position. Located in bottom of floor mounted units only (models RF and RS).

Filters

Cleanable aluminum mesh

- 1" aluminum mesh filter complete with aluminum frame & drain holes. Contact the factory for 1" MERV 8 or higher pleated filters.

Controls

Fan control by air temperature

- Remote or unit mounted thermostat monitors air temperature in the space. When the temperature drops below set point during heating, the heating valve will open and the fan will turn on. When the space temperature is satisfied, the valve will close and the fan will turn off. A remote temperature sensor is offered with all thermostat options for remote mounting in space or in return air stream.

Fan control by water temperature

- Aquastat monitors the temperature of water leaving the coil. It will delay the motor blower until a pre-determined water temperature is reached.

Valve control by air temperature

- Remote or unit mounted thermostat monitors air temperature in the space. When the temperature drops below set point, the heating valve will open. When the space temperature is satisfied, the valve will close. The blower runs continuously based on three-speed switch positions. A remote temperature sensor is offered with all thermostat options for remote mounting in space or in return air stream.

Remote temperature sensor

- Recommended with all unit mounted thermostats. Operates with all standard Zehnder Rittling control packages with the removal of JP1 jumper, internal to thermostat.

Freezestat

- Provides temperature or limit control by shutting off power to fan and valves when the return air temperature drops to setpoint. Setpoint range of 15 to 55 °F with stop limits minimum to 34 °F.

24V transformer (24VT)

- 40VA, 120V/24V transformer is unit mounted with 120V pre-wired, ready for 24V field wiring. (24T3) includes three-speed switch.

24V relay (24VR)

- Relay is unit mounted, ready for field wiring. 24R3 includes three-speed switch.

24V fan center (24FC)

- Includes a 40VA, 120V/24V transformer and one (1) 24V relay. Fan center is unit mounted with 120V pre-wired, ready for 24V field wiring. (24F3) includes a three-speed switch.

24V relay pack (24RP)

- Includes a 40VA, 120V/24V transformer and three 24V relays. Relay pack is unit mounted with 120V pre-wired, ready for 24V field wiring.

Field assembled

Wall seal

- Used to recess wall and ceiling models (included as standard with all fully and partially recessed units).

Outside air wall box

- Aluminum wall box, shipped loose, to match up to outside air damper opening. Telescoping feature allows flexibility for varying wall depths. Insect screen is included to keep debris from entering unit.

Valve packages

- Shipped loose for field installation. See pages 18-22 for more information.
- Contact the factory for unit mounted unions, mounting of customer supplied valves, hose kits or high pressure close-off control valves.

Table A: Standard ratings and specifications

Specifications		02	03	04	06	08	10	12
Steam capacity	MBH	18.7	25.5	34.8	51.0	62.8	73.4	90.7
	EDR	76	104	144	212	260	304	376
Hot water capacity (1 row coil)	MBH	16.2	22.4	30.7	45.5	54.8	64.5	80.1
	GPM	1.7	2.3	3.2	4.8	5.7	6.7	8.4
	WPD	0.2	0.4	0.8	2.2	0.5	0.7	1.2
Hot water capacity (2 row coil)	MBH	25.0	34.3	47.2	69.5	86.6	101.2	125.8
	GPM	2.6	3.6	4.9	7.3	9.0	10.5	13.1
	WPD	0.8	1.7	3.6	9.3	2.2	3.3	5.6
CFM: standard	High	220	300	420	620	810	940	1180
	Medium	150	200	310	450	600	720	875
	Low	125	140	220	350	440	480	660
CFM: high static (@ 0.2" ESP)	High	250	345	490	640	920	1020	1150
	Medium	210	290	425	550	780	870	980
	Low	160	230	320	420	590	660	750
Coil	FPI	12	12	12	12	12	12	12
	Face area, ft2	1.25	1.67	2.08	2.92	3.33	3.89	4.58
	Coil connections	1/2" Cu	1/2" Cu	1/2" Cu	1/2" Cu	1/2" Cu	1/2" Cu	1/2" Cu
Blower	Quantity	1	1	2	2	1, 2	4	4
	Diameter	5.7"	5.7"	5.7"	5.7"	5.7"	5.7"	5.7"
	Width	7.5"	10.4"	7.5"	10.4"	7.5", 10.4"	7.5"	10.4"
Filter	Number	1	1	1	1	1	1	1
	Length, in.	22	28	34	46	52	60	70
	Width, in. - standard	9.75	9.75	9.75	9.75	9.75	9.75	9.75
	Width, in. - floor with inlet grille	7.25	7.25	7.25	7.25	7.25	7.25	7.25
	Rating	Merv 4	Merv 4	Merv 4	Merv 4	Merv 4	Merv 4	Merv 4
Cabinet size	Thickness, in.	1	1	1	1	1	1	1
	Length, in.	38.2	44.2	50.2	62.2	68.2	76.2	86.2
	Width, in.	10	10	10	10	10	10	10
	Height, in. - wall/ceiling	24	24	24	24	24	24	24
	Height, in. - flat top floor	26.5	26.5	26.5	26.5	26.5	26.5	26.5
	Height, in. - slope top floor	29.25	29.25	29.25	29.25	29.25	29.25	29.25
Shipping weight, lbs.		85	100	115	140	155	170	195

Notes

- Airflows for floor mounted units with 1-row coil. Please check with factory for adjusted outputs on other models
- Heating capacity based on inlet air 60 °F DB, 200°F entering water or 2 psig steam, 180°F leaving water, standard motor at high fan speed
- Pressure drop (PD) shown in feet of water
- Overall length for fully and partially recessed units is length +3", adding in the trim kit. Wall rough-in hole dimension to be length +1/2" by 24-1/2" minimum. Maximum opening to be length by +2" by 26".



Table B: Electrical data

		Motor Type	02	03	04	06	08	10	12
HP	PSC	Standard	1/30	1/30	1/25	1/15	1/30, 1/15	(2) 1/15	(2) 1/15
		High-Static	1/12	1/12	1/10	1/7	1/12, 1/7	(2) 1/7	(2) 1/7
	ECM	Standard	1/4	1/4	1/4	1/4	(2) 1/4	(2) 1/4	(2) 1/4
		High-Static	1/4	1/4	1/4	1/4	(2) 1/4	(2) 1/4	(2) 1/4
RPM High	PSC	Standard	895	995	900	1150	1150	1250	1200
		High-Static	1505	1510	1550	1550	1550	1550	1550
	ECM	Standard	1050	1025	920	1120	1150	1250	1200
		High-Static	1550	1550	1550	1550	1550	1550	1550
RPM Medium	PSC	Standard	833	754	720	900	900	860	950
		High-Static	1390	1320	1320	1320	1320	1320	1320
	ECM	Standard	875	700	720	870	900	850	950
		High-Static	1320	1320	1320	1320	1320	1320	1320
RPM Low	PSC	Standard	620	575	530	710	625	650	550
		High-Static	1300	1200	1000	1000	1000	1000	1000
	ECM	Standard	750	600	530	685	625	640	550
		High-Static	1000	1000	1000	1000	1000	1000	1000
Motor FLA 120V	PSC	Standard	0.60	0.60	0.68	1.13	1.73	2.26	2.26
		High-Static	1.05	1.05	1.2	1.7	2.8	3.4	3.4
	ECM	Standard	0.92	0.84	1.12	1.70	2.85	3.04	3.58
Power Input: Watts 120V	PSC	Standard	57	61	75	130	200	240	250
		High-Static	117	120	130	180	325	368	368
	ECM	Standard	38	38	45	80	125	147	157

Notes:

- Maximum circuit ampacity (MCA) =
1.25 x (FLA motor 1 + FLA motor 2 + FLA electric heat)
- Maximum overcurrent protection (MOP) =
(2.25 x FLA motor 1) + FLA motor 2 + FLA electric heat
- If the calculated MOP is within 10% of the next smaller available fuse size, that fuse size shall be used. If not, the next larger fuse size above the calculated MOP must be used.
- If the selected MOP is smaller than the MCA, the selected MOP must be increased to the next larger available fuse size above the MCA.
- If the MOP is less than 15, it shall be rounded up to 15 amps. This is the minimum fuse or circuit breaker permitted by code.
- EC motor nameplate amperage indicates the motor hardware peak amperage while the motor full load amperage (FLA) is limited by the motor's factory programmed operating range, programmed specifically for each unit size. The programmed operating range is generally only a portion of the motor hardware full potential resulting in the motor FLA being lower than the nameplate FLA. Motor FLA will be reflected on the Cabinet Unit Heater serial tag and should be used when sizing building electrical requirements.



Valve packages general data

Field mounted valve packages

Zehnder Rittling Cabinet Unit Heaters have standard hot water valve packages available as a factory-built assembly, pre-wired and field-installed option for the heating cooling coil. All valve packages are manufactured within strict tolerances and are hydrostatically tested for leaks. Valve packages are shipped loose for field assembly to ensure a leak free system as factory mounted valve packages often become damaged during shipment.

Valve package components

■ Zehnder Rittling valve packages consist of a variety of components and selection of each combination is dependent upon the application. The following sections provide a detailed description of each of the components. Following this section are additional schematic illustrations and mechanical specifications and photos.

Piping system/placement

■ Valve packages are available with left and/or right hand connections. All coil connections are left hand as standard unless specified differently.

Interconnecting piping

■ Interconnecting piping refers to the copper piping which is attached to the coil connections and to which all other components (i.e. control valves, end valves, circuit setters, etc.) are attached. Piping is 1/2" nominal (5/8" OD) copper.

Deluxe or basic packages

■ The basic valve package includes only the main components of the valve package (i.e. interconnecting piping, control valves, and end valves). The deluxe valve packages

also include unions at the coil connections and a strainer on the supply water pipe along with the basic components. All valve package components are solder end connections.

Unions

■ Feature cast bronze construction and close with a minimum amount of effort. Used for quick connect and disconnect of valve package components to minimize required field labor during servicing of the unit.

Strainer

■ The Y-type strainer body is constructed of brass with a 16 mesh 304 stainless steel screen. Used for removal of small particles from the water supply pipe during normal system operation. The strainer helps protect the coil and minimizes the chance of control valves clogging. Screens should be regularly removed and cleaned as part of a routine maintenance schedule.



Balance valves

■ The valve body is constructed of bronze and is used to balance hydronic circuits.

End valves

Each valve package includes a ball valve for supply water pipe and one of the following end valves on the return water pipe; ball valve, manual circuit setter, or automatic circuit setter. Consult factory for inclusion of other types of valves as end valves.

Ball valves

■ Ball valves, a.k.a. end valves, allow the unit to be cut off for servicing purposes. They have a low resistance to water flow, operate easily, and are often used for water balancing. These valves have a compact handle that rotates 90 degrees to a fully open position.

■ The valve body is forged brass and the ball is polished brass with virgin Teflon seats and seals. Ball valves are available as end valves on both the supply and return water pipes.

Manual circuit setter

■ A manual circuit setter, a.k.a. manual flow control valve, acts as both a flow setting device and a stop valve, taking the place of a ball valve. This valve allows water flow through the fan coil unit and can be set quickly and accurately. Manual circuit setter includes two measuring ports in the valve body for pressure drop measurements during system balancing. This pressure drop can be compared to factory supplied curves showing the corresponding flow rate. This valve has a handwheel with memory feature including a locking feature for tamperproof setting.

Automatic circuit setter

- An automatic circuit setter is an automatic flow control device that includes a ball valve cast in the valve body and is located on the return water pipe. The automatic circuit setter consists of a stainless steel/brass flow cartridge and a contoured orifice plate. As the pressure drop increases, the flow cartridge will move into the contoured orifice plate to decrease the flow. This flexing action provides a constant flow, independent of pressure (2-80 psi), makes it difficult to clog and resistant to cavitation damage. This valve sets flow through the coil without any action required by a system balancer. The automatic circuit setter includes two measuring ports in the valve body to be used for pressure drop and temperature measurements.

Control valves

Valve packages are available with or without control valves.

2-way on/off valves

- These 1/2" valves are normally closed to the coil as standard and will isolate the coil during a loss of power. Normally open valves are also available upon request. Upon response to a signal from the controller, the valve will be either fully open or fully closed. These valves are located in the water supply pipe and have a c_v of 3.5, and close off ΔP of 25 psi. A means of relieving head pressure must be accounted for when two-way valves are selected, most notably when used in combination with automatic changeover.

3-way on/off valves

- These 1/2" valves are normally closed to the coil as standard and will isolate the coil during a loss of power. Normally open configurations are simply achieved by turning the valve around. Upon response to a signal from the controller, the valve will be either fully open, allowing full flow to the coil, or fully closed, diverting full flow to the bypass line. All three-way valve configurations include a balance fitting in the bypass line to allow proper flow balancing. These valves are located in the water supply pipe and have a c_v of 4.0, and close off ΔP of 25 psi.

2-way modulating valves

- 1/2", 24V valves modulate the flow of water (0-100%) through the coil in response to a signal from the controller and are normally closed to the coil as standard. Normally open valves are also available upon request. All modulating valves are three-wire floating equal percentage valves, designed for precise temperature control. All valves feature a magnetic clutch to extend the life of the motor and gear train, manual operating lever/position indicator facilitates field setup, and easy to use lever terminal blocks. These valves are located in the water supply pipe, have a c_v of 4.0, and close off ΔP of 20 psi. A means of relieving pump head pressure must be accounted for when two-way valves are selected, most notably when used in combination with automatic changeover.

3-way modulating valves

- These 1/2", 24V valves modulate the flow of water (0-100%) through the coil in response to a signal from the controller and are normally closed to the coil as standard. Normally open configurations are simply achieved by turning the valve around. three-way valves allow the water supply from the water supply pipe to mix with bypass water from the bypass line. This mixture exits through the supply water pipe to the coil. All modulating valves are three-wire floating equal percentage valves, designed for precise temperature control. All valves feature a magnetic clutch to extend the life of the motor and gear train, manual operating lever/position indicator facilitates field setup, and easy to use lever terminal blocks. These valves are located in the water supply pipe, have a c_v of 4.0, and close off ΔP of 20 psi.

Please contact Zehnder Rittling regarding any special valve requirements including high close-off pressure control valves, hose kits, additional P/T ports, customer supplied valves, etc.

Basic valve packages

Pre-assembled packages, shipped loose for field mounting			
Control valve	Basic	Circuit setter	Automatic circuit setter
None	V-B1 <ul style="list-style-type: none"> Ball valve on supply Ball valve on return 	V-B2 <ul style="list-style-type: none"> Ball valve on supply Manual circuit setter on return 	V-B3 <ul style="list-style-type: none"> Ball valve on supply Auto circuit setter and ball valve on return
2-way on/off	V-B4E <ul style="list-style-type: none"> 2-way electric valve and ball valve on supply Ball valve on return 	V-B5E <ul style="list-style-type: none"> 2-way electric valve and ball valve on supply Manual circuit setter on return 	V-B6E <ul style="list-style-type: none"> 2-way electric valve and ball valve on supply Auto circuit setter and ball valve on return
2-way modulating	V-B4M <ul style="list-style-type: none"> 2-way electric valve and ball valve on supply Ball valve on return 	V-B5M <ul style="list-style-type: none"> 2-way electric valve and ball valve on supply Manual circuit setter on return 	V-B6M <ul style="list-style-type: none"> 2-way electric valve and ball valve on supply Auto circuit setter and ball valve on return
3-way on/off	V-B7E <ul style="list-style-type: none"> 3-way electric valve and ball valve on supply Balance fitting in bypass Ball valve on return 	V-B8E <ul style="list-style-type: none"> 3-way electric valve and ball valve on supply Balance fitting in bypass Manual circuit setter on return 	V-B9E <ul style="list-style-type: none"> 3-way electric valve and ball valve on supply Balance fitting in bypass Auto circuit setter and ball valve on return
3-way modulating	V-B7M <ul style="list-style-type: none"> Ball valve on supply Balance fitting in bypass 3-way electric valve and ball valve on return 	V-B8M <ul style="list-style-type: none"> Ball valve on supply Balance fitting in bypass 3-way electric valve and manual circuit setter on return 	V-B9M <ul style="list-style-type: none"> Ball valve on supply Balance fitting in bypass 3-way electric valve, Auto circuit setter and ball valve on return





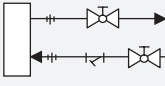
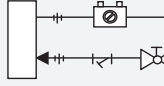
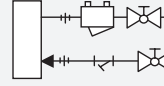
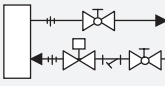
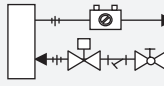
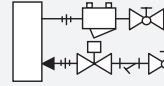
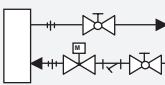
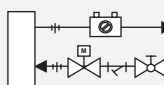
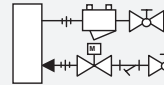
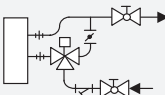
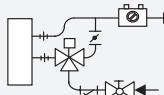
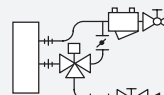
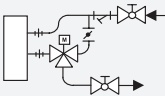
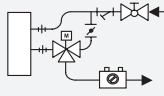
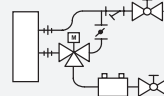

Miscellaneous Ship Loose Parts

V-2E <ul style="list-style-type: none"> 2-way electric on/off valve on supply 	V-3E <ul style="list-style-type: none"> 3-way electric on/off valve on supply
V-2M <ul style="list-style-type: none"> 2-way electric modulating valve on supply 	V-3M <ul style="list-style-type: none"> 3-way electric modulating valve on return

Deluxe valve packages

Pre-assembled packages, shipped loose for field mounting			
Control valve	Basic	Circuit setter	Automatic circuit setter
None	<p>V-D1</p> <ul style="list-style-type: none"> Ball valve, union and strainer on supply. Ball valve and union on return. 	<p>V-D2</p> <ul style="list-style-type: none"> Ball valve, union and strainer on supply. Manual circuit setter and union on return. 	<p>V-D3</p> <ul style="list-style-type: none"> Ball valve, union and strainer on supply. Auto circuit setter, union and ball valve on return. 
2-way on/off	<p>V-D4E</p> <ul style="list-style-type: none"> 2-way electric valve, ball valve, union and strainer on supply. Ball valve and union on return. 	<p>V-D5E</p> <ul style="list-style-type: none"> 2-way electric valve, ball valve, union and strainer on supply. Manual circuit setter and union on return. 	<p>V-D6E</p> <ul style="list-style-type: none"> 2-way electric valve, ball valve, union and strainer on supply. Auto circuit setter, union and ball valve on return. 
2-way modulating	<p>V-D4M</p> <ul style="list-style-type: none"> 2-way electric valve, ball valve, union and strainer on supply. Ball valve and union on return. 	<p>V-D5M</p> <ul style="list-style-type: none"> 2-way electric valve, ball valve, union and strainer on supply. Manual circuit setter and union on return. 	<p>V-D6M</p> <ul style="list-style-type: none"> 2-way electric valve, ball valve, union and strainer on supply. Auto circuit setter, union, and ball valve on return. 
3-way on/off	<p>V-D7E</p> <ul style="list-style-type: none"> 3-way electric valve, ball valve, union and strainer on supply Balance fitting in bypass. Ball valve and union on return. 	<p>V-D8E</p> <ul style="list-style-type: none"> 3-way electric valve, ball valve, union and strainer on supply Balance fitting in bypass. Manual circuit setter and union on return. 	<p>V-D9E</p> <ul style="list-style-type: none"> 3-way electric valve, ball valve, union and strainer on supply Balance fitting in bypass. Auto circuit setter, union and ball valve on return. 
3-way modulating	<p>V-D7M</p> <ul style="list-style-type: none"> Ball valve, strainer and union on supply. Balance fitting in bypass. 3-way electric valve, ball valve and union on return. 	<p>V-D8M</p> <ul style="list-style-type: none"> Ball valve, strainer and union on supply . Balance fitting in bypass. 3-way electric valve, manual circuit setter and union on return. 	<p>V-D9M</p> <ul style="list-style-type: none"> Ball valve, strainer and union on supply. Balance fitting in bypass. 3-way electric valve, auto circuit setter, union and ball valve on return. 

Valve packages components mechanical specifications

Component		Part	Material	Temperature	Working pressure
Union		Nut	Forged brass	325 °F maximum	600 psi
		Body			
Balance valve		Body	Bronze	220 °F maximum	300 psi
		O-ring	EPDM		
Automatic circuit setter and ball valve		Body	Forged brass	325 °F maximum	600 psi
		Ball	Brass/chrome plated		
		Flow cartridge	Stainless steel/brass		
		Seals	Viton		
		Ball seal	PTFE		
Manual circuit setter		Body	Bronze	250 °F maximum	200 psi
		Ball	Brass		
		Seat rings	Glass and carbon filled TFE		
		O-ring	EPDM		
Ball valve		Body	Forged brass	325 °F maximum	600 psi
		Ball	Brass/chrome plated		
		Seat	PTFE		
		Stem	Brass		
		Seals	Viton		
Strainer and ball valve with union		Body	Forged brass	325 °F maximum	600 psi
		Ball	Brass/chrome plated		
		Seat	PTFE		
		Stem	Brass		
		Seals	Viton		
		Screen	304 stainless steel (20 mesh)		
Control valve		Body	Forged brass	200 °F maximum	300 psi
		Stem	Nickel plated/chrome plated brass		
		Seat	Brass		
		Paddle/plug	On/off: Buna N Modulating: High temperature thermoplastic/rubber		
		Actuator	On/off: stainless steel base plate, aluminum cove Modulating: high temperature plastic		

120 volt control packages

Electronic on-off valve/thermostat

Zehnder Rittling provides a control system that includes a thermostat, control board with relays, and manually operated three-speed fan switch. For fan cycle operation, the thermostat cycles the fan from the selected speed to off. No control valve is provided in this operation. For fan/valve cycle operation, the thermostat cycles the fan and control valve. The fan runs intermittently unless the speed control switch is in the off position. Valve is not included in the control package price.

Two pipe control: Fan cycled or fan/valve cycled

Package number	Thermostat description	Fan motor speed switch location
2F0C	On/off system switch and three-speed fan control	Unit mounted, integral to thermostat
2F0D		Wall mounted, integral to thermostat

Notes:

- A means of relieving pump head pressure must be accounted for when two-way valves are used with an automatic thermostat package
- The fan cycles with demand for heating, but if the system switch is off, the fan is off
- Remote temperature sensors are recommended with all unit mounted thermostats for improved temperature control

Zehnder Rittling provides a control system that includes a thermostat, control board, and manually operated three-speed fan switch and changeover switch (when required). The thermostat cycles the electric control valve. The fan runs continuously. Valve is not included in the control package price.

Two pipe control: Valve cycled

Package number	Thermostat description	Fan motor speed switch location
2V0C	On/off system switch and three-speed fan control	Unit mounted, integral to thermostat
2V0D		Wall mounted, integral to thermostat

Notes:

- A means of relieving pump head pressure must be accounted for when two-way valves are used with an automatic thermostat package
- The fan runs continuously, but if the system switch is off, the fan is off
- Remote temperature sensors are recommended with all unit mounted thermostats for improved temperature control

24 volt control packages

Electronic on-off valve/thermostat

Zehnder Rittling provides a control system that includes a thermostat, control board with 40VA 120V/24V control transformer and relays, and manually operated three-speed fan switch. For fan cycle operation, the thermostat cycles the fan from the selected speed to off. No control valve is provided in this operation. For fan/valve cycle operation, the thermostat cycles the fan and control valve. The fan runs intermittently unless the speed control switch is in the off position. Valve is not included in the control package price.

Two pipe control: Fan cycled or fan/valve cycled

24V power to thermostat with 120V power from thermostat to motor

Package number	Thermostat description	Fan motor speed switch location
2F4C	On/off system switch and 120V three-speed fan control	Unit mounted, integral to thermostat
2F4D		Wall mounted, integral to thermostat

Notes:

- A means of relieving pump head pressure must be accounted for when two-way valves are used with an automatic thermostat package
- The fan cycles with demand for heating, but if the system switch is off, the fan is off
- Remote temperature sensors are recommended with all unit mounted thermostats for improved temperature control

Two pipe control: Fan cycled or fan/valve cycled

24V power only

Package number	Thermostat description	Fan motor speed switch location
2F4J	On/off system switch and 24V three-speed fan control	Unit mounted, integral to thermostat
2F4K		Wall mounted, integral to thermostat

Notes:

- A means of relieving pump head pressure must be accounted for when two-way valves are used with an automatic thermostat package
- Three additional 24V relays are included for a completely low voltage control package option
- The fan cycles with demand for heating, but if the system switch is off, the fan is off
- Remote temperature sensors are recommended with all unit mounted thermostats for improved temperature control

24 volt control packages

Zehnder Rittling provides a control system that includes a thermostat, control board with 40VA 120V/24V control transformer, and manually operated three-speed fan switch. The thermostat cycles the electric control valve. The fan runs continuously. Valve is not included in the control package price.

Two pipe control: Valve cycle

24V power to thermostat with 120V power from thermostat to motor

Package number	Thermostat description	Fan motor speed switch location
2V4C	On/off system switch and 24V three-speed fan control	Unit mounted, integral to thermostat
2V4D		Wall mounted, integral to thermostat

Notes:

- A means of relieving pump head pressure must be accounted for when two-way valves are used with an automatic thermostat package
- The fan runs continuously, but if the system switch is off, the fan is off
- Remote temperature sensors are recommended with all unit mounted thermostats for improved temperature control

Electronic modulating valve thermostat

Two pipe with two-way or three-way modulating valves

Package number	Thermostat description	Fan motor speed switch location
2M4A	No system switch or fan control	Unit mounted, separate from wall mounted thermostat

Notes:

- Fan runs continuously depending on position of unit mounted three-speed fan motor switch
- Available with EC motors

Miscellaneous control packages

Package number	Package description	Fan motor speed switch
24VR	Unit mounted 24V relay, ready for field wiring	No
24R3		Yes
24VT	Unit mounted 40VA, 120V/24V transformer with 120V pre-wired and 24V ready for field wiring	No
24T3		Yes
24FC	Unit mounted fan center includes a 40VA, 120V/24V transformer and one 24V relay with 120V pre-wired and 24V ready for field wiring	No
24F3		Yes
24RP	Unit mounted relay pack includes a 40VA, 120V/24V transformer and three 24V relays with 120V pre-wired and 24V ready for field wiring	No

Dimensions and data

Models RF and RFI

Front view

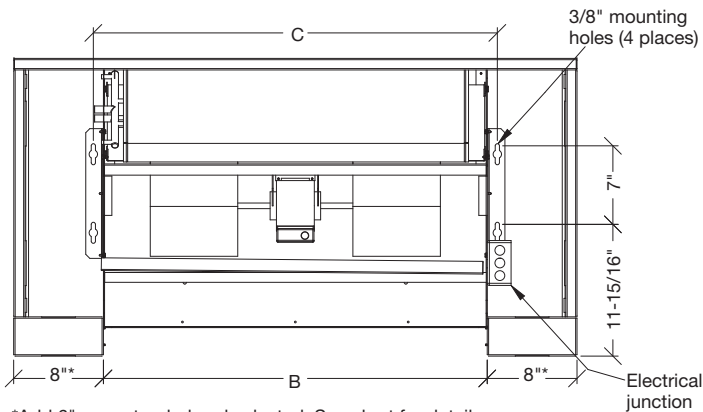

*Add 6" per extended end selected. See chart for details.

Top view

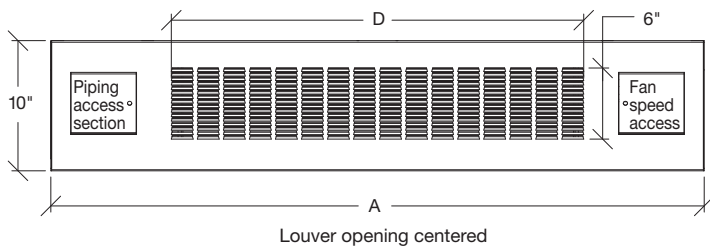

Side view: Model RFI

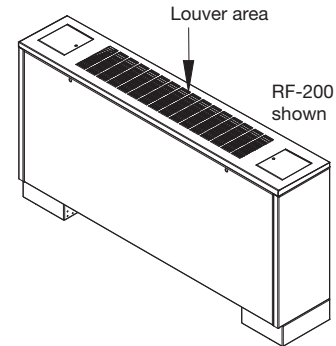
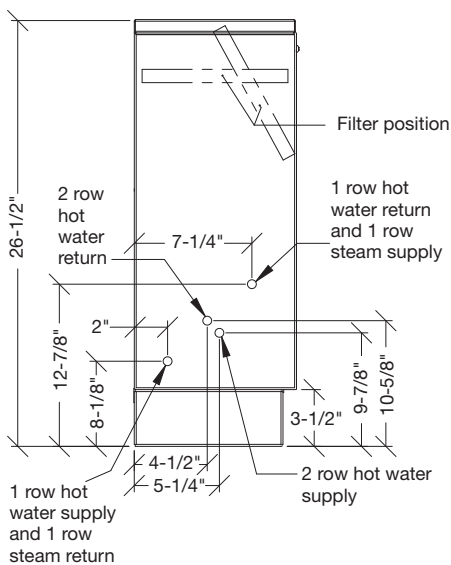

Side view: Model RF

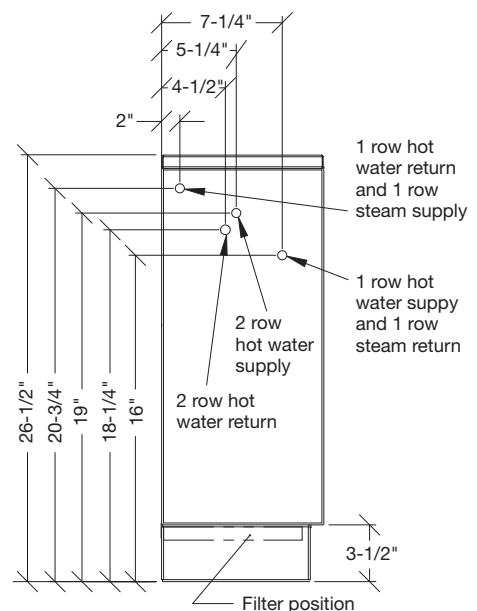

Dimensional data

Unit size	A			B	C	D
	Std.	6" Ext.	6" Ext. x2			
02	38-3/16	44-3/16	50-3/16	22-3/16	24	20
03	44-3/16	50-3/16	56-3/16	28-3/16	30	26
04	50-3/16	56-3/16	62-3/16	34-3/16	36	32
06	62-3/16	68-3/16	74-3/16	46-3/16	48	44
08	68-3/16	74-3/16	80-3/16	52-3/16	54	50
10	76-3/16	82-3/16	88-3/16	60-3/16	62	58
12	86-3/16	92-3/16	98-3/16	70-3/16	72	68

Notes:

- 1 and 2 row coil supply and return 1/2" nominal (5/8" OD) all sizes
- Inlet grille optional
- Unit shown with left hand piping connections and right hand electrical connections as standard
- Right hand piping connections with left hand electrical connections available as an option
- Piping hand determined when facing the air outlet
- All listed dimensions are approximate and are subject to change without notice
- Modifications to the product specifications must be accepted by Zehnder Rittling at its base office
- See www.zehnder-rittling.com for any recent updates or changes

Dimensions and data

Models RS and RSI

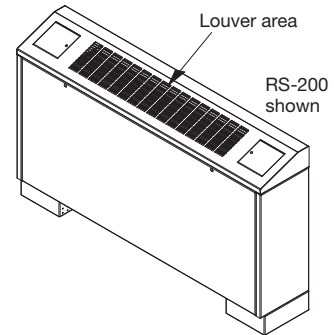

Side view: Model RS

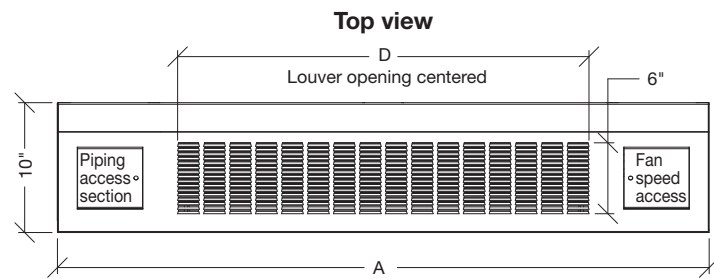
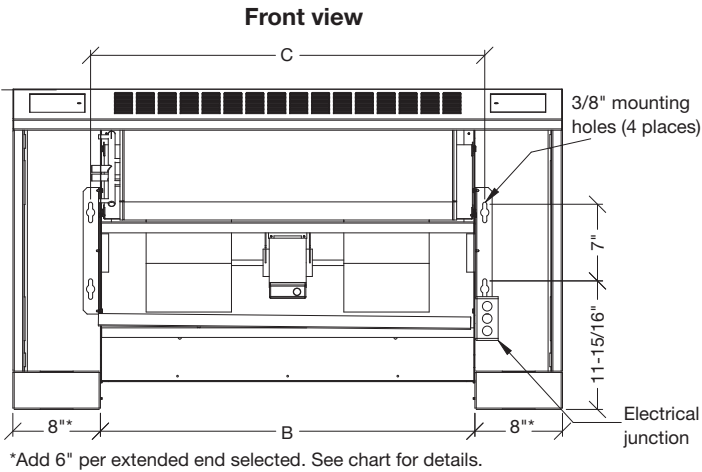
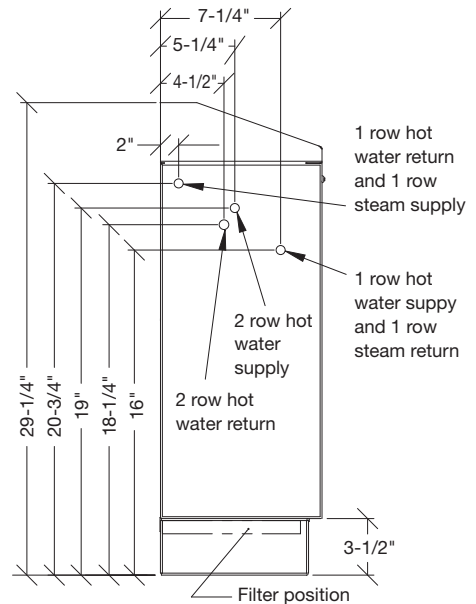

Side view: Model RSI

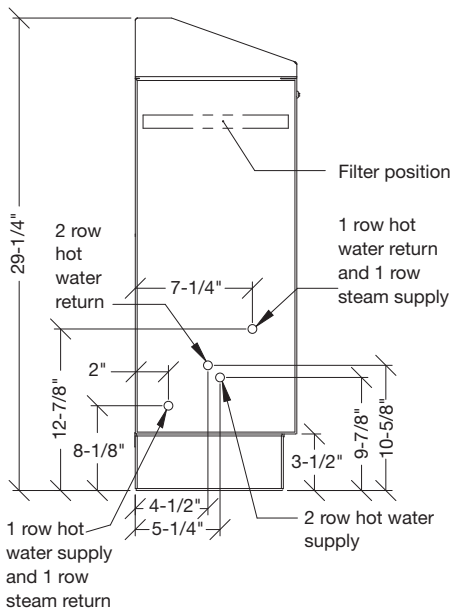

Dimensional data

Unit size	A			B	C	D
	Std.	6" Ext.	6" Ext. x2			
02	38-3/16	44-3/16	50-3/16	22-3/16	24	20
03	44-3/16	50-3/16	56-3/16	28-3/16	30	26
04	50-3/16	56-3/16	62-3/16	34-3/16	36	32
06	62-3/16	68-3/16	74-3/16	46-3/16	48	44
08	68-3/16	74-3/16	80-3/16	52-3/16	54	50
10	76-3/16	82-3/16	88-3/16	60-3/16	62	58
12	86-3/16	92-3/16	98-3/16	70-3/16	72	68

Notes:

- 1 and 2 row coil supply and return 1/2" nominal (5/8" OD) all sizes
- Inlet grille optional
- Unit shown with left hand piping connections and right hand electrical connections as standard
- Right hand piping connections with left hand electrical connections available as an option
- Piping hand determined when facing the air outlet
- All listed dimensions are approximate and are subject to change without notice
- Modifications to the product specifications must be accepted by Zehnder Rittling at its base office
- See www.zehnder-rittling.com for any recent updates or changes

Dimensions and data

Models RW, RWI and RC

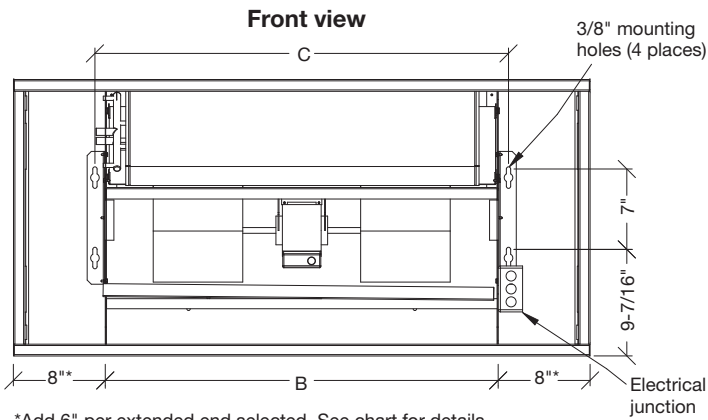

*Add 6" per extended end selected. See chart for details.

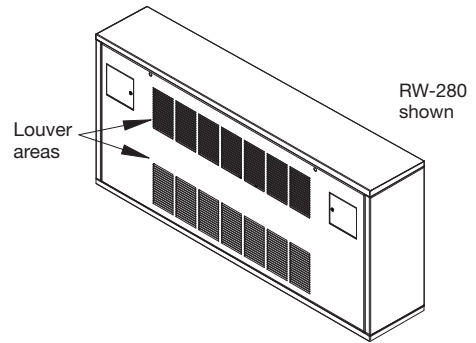
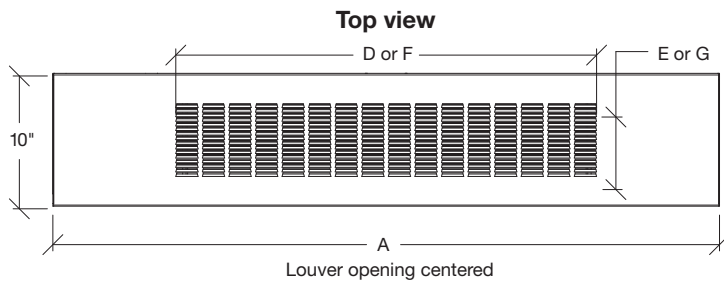

Side view: Models RW and RC

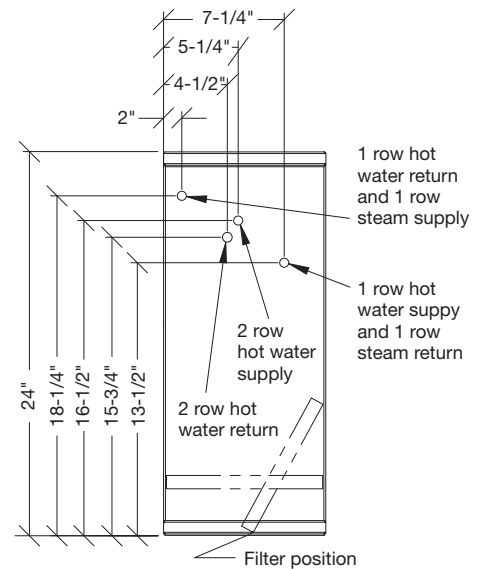

Side view: Model RWI

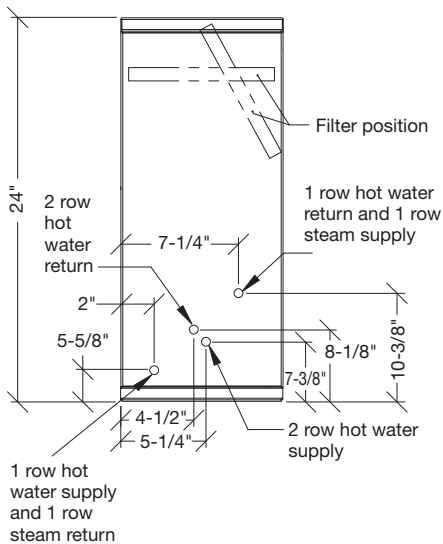

Dimensional data

Unit size	A			B	C	Louvers		Ducted opening	
	Std.	6" Ext.	6" Ext. x2			D	E	F	G
02	38-3/16	44-3/16	50-3/16	22-3/16	24	20	6	18-3/8	5-1/8
03	44-3/16	50-3/16	56-3/16	28-3/16	30	26	6	24-3/16	5-1/8
04	50-3/16	56-3/16	62-3/16	34-3/16	36	32	6	30-3/16	5-1/8
06	62-3/16	68-3/16	74-3/16	46-3/16	48	44	6	42-3/16	5-1/8
08	68-3/16	74-3/16	80-3/16	52-3/16	54	50	6	48-3/16	5-1/8
10	76-3/16	82-3/16	88-3/16	60-3/16	62	58	6	56-3/16	5-1/8
12	86-3/16	92-3/16	98-3/16	70-3/16	72	68	6	66-3/16	5-1/8

Notes:

- 1 and 2 row coil supply and return 1/2" nominal (5/8" OD) all sizes
- Inlet grille optional
- Unit shown with left hand piping connections and right hand electrical connections as standard
- Right hand piping connections with left hand electrical connections available as an option
- Piping hand determined when facing the air outlet
- All listed dimensions are approximate and are subject to change without notice
- Modifications to the product specifications must be accepted by Zehnder Rittling at its base office
- See www.zehnder-rittling.com for any recent updates or changes

Dimensions and data

Models RRW, RFRW, RRC, RFRW, RRWI and RFRWI

Front view

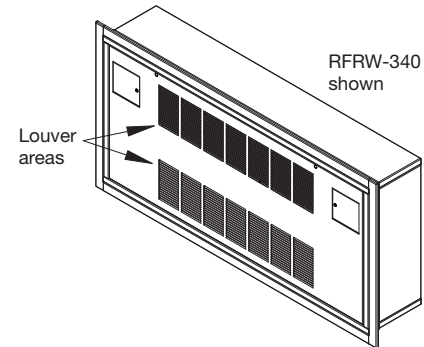
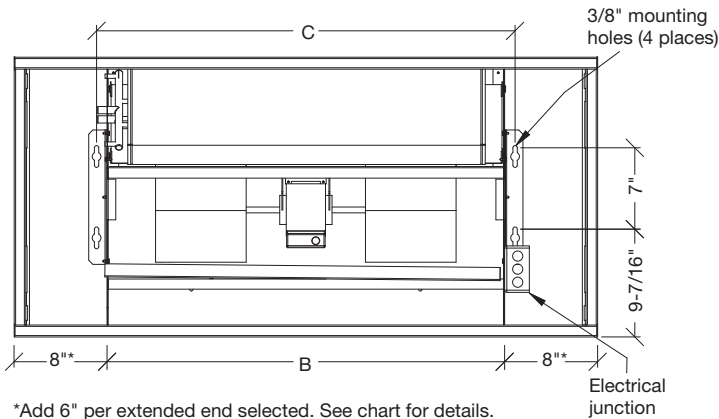

Side view: Models RRW, RFRW, RRC and RFRW

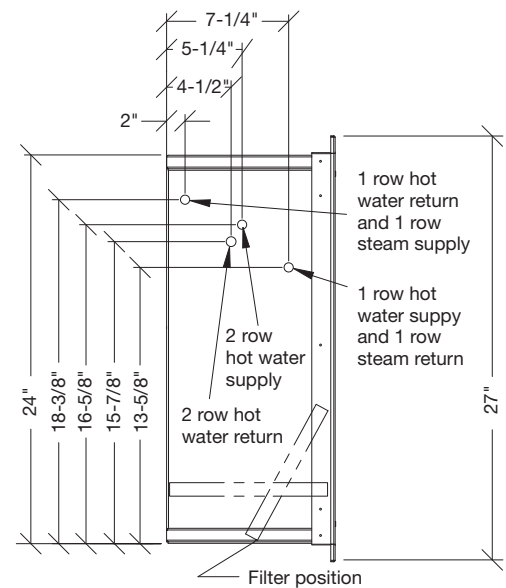

Top view

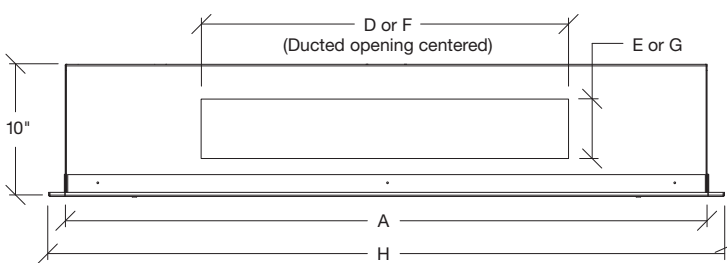

Side view: Models RRWI and RFRWI

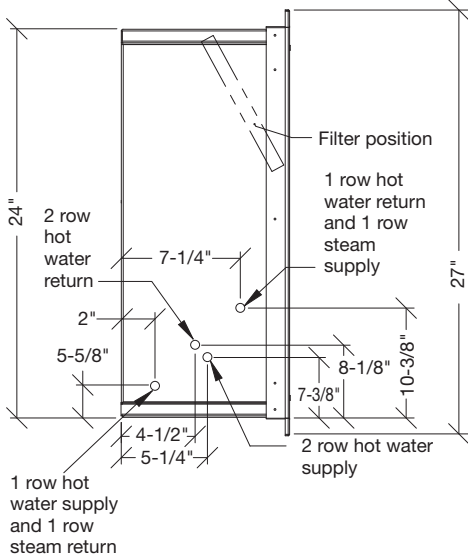

Dimensional data

Unit size	A			B	C	Louvers		Duct opening		H		
	Std.	6" Ext.	6" Ext. x2			D	E	F	G	Std.	6" Ext.	6" Ext. x2
02	38-3/16	44-3/16	50-3/16	22-3/16	24	20	6	18-3/8	5-1/8	41-3/16	47-3/16	53-3/16
03	44-3/16	50-3/16	56-3/16	28-3/16	30	26	6	24-3/16	5-1/8	47-3/16	53-3/16	59-3/16
04	50-3/16	56-3/16	62-3/16	34-3/16	36	32	6	30-3/16	5-1/8	53-3/16	59-3/16	65-3/16
06	62-3/16	68-3/16	74-3/16	46-3/16	48	44	6	42-3/16	5-1/8	65-3/16	71-3/16	77-3/16
08	68-3/16	74-3/16	80-3/16	52-3/16	54	50	6	48-3/16	5-1/8	71-3/16	77-3/16	83-3/16
10	76-3/16	82-3/16	88-3/16	60-3/16	62	58	6	56-3/16	5-1/8	79-3/16	85-3/16	91-3/16
12	86-3/16	92-3/16	98-3/16	70-3/16	72	68	6	66-3/16	5-1/8	89-3/16	95-3/16	101-3/16

Notes:

- 1 and 2 row coil supply and return 1/2" nominal (5/8" OD) all sizes
- Unit shown with left hand piping connections and right hand electrical connections as standard
- Right hand piping connections with left hand electrical connections available as an option
- Piping hand determined when facing the air outlet
- All listed dimensions are approximate and are subject to change without notice
- Modifications to the product specifications must be accepted by Zehnder Rittling at its base office
- See www.zehnder-rittling.com for any recent updates or changes

Dimensions and data

Damper

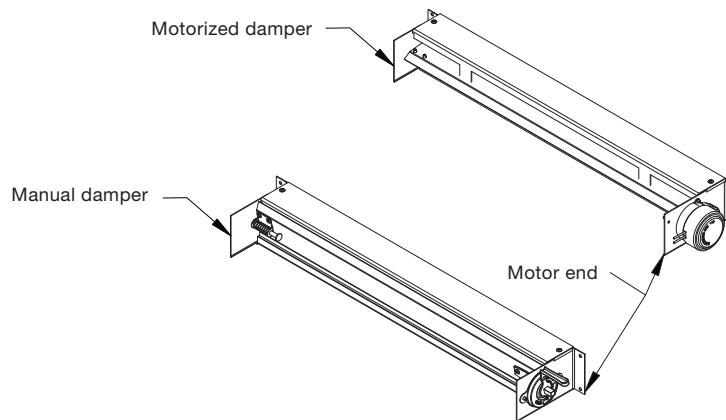
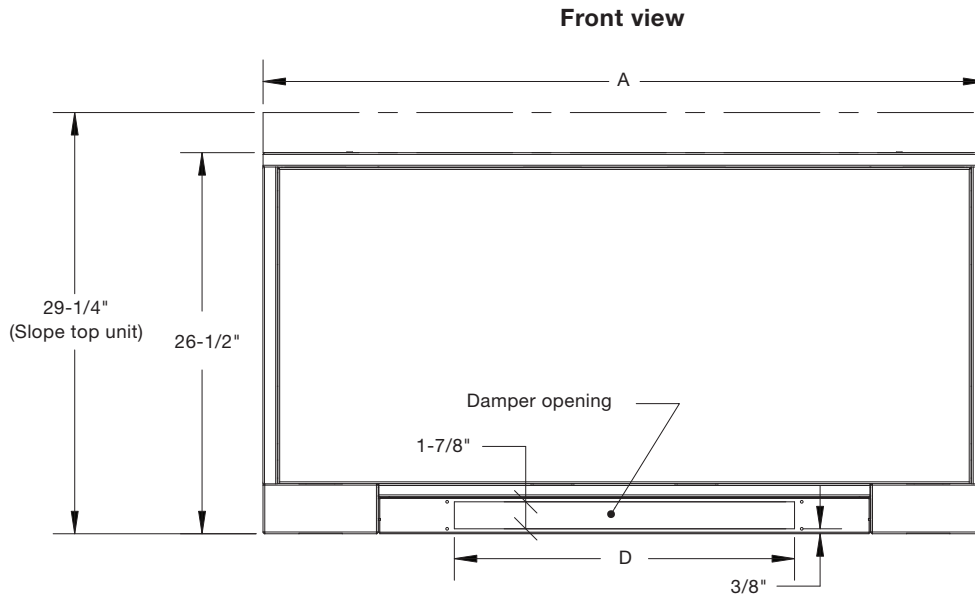

Dimensional data

Unit size	A	B	C	D
02	38-3/16	22-3/8	24	18-5/8
03	44-3/16	28-3/8	30	18-5/8
04	50-3/16	34-3/8	36	23-5/8
06	62-3/16	46-3/8	48	23-5/8
08	68-3/16	52-3/8	54	33-5/8
10	76-3/16	60-3/8	62	33-5/8
12	86-3/16	70-3/8	72	33-5/8

Notes:

- Damper motor always on right side when viewing unit from front side.
- All listed dimensions are approximate and are subject to change without notice. Modifications to the product specifications must be accepted by Zehnder Rittling at its base office.
- Available for models RF and RS only.

Dimensions and data

Outside air wall box

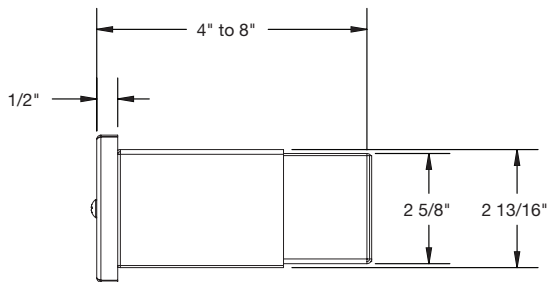
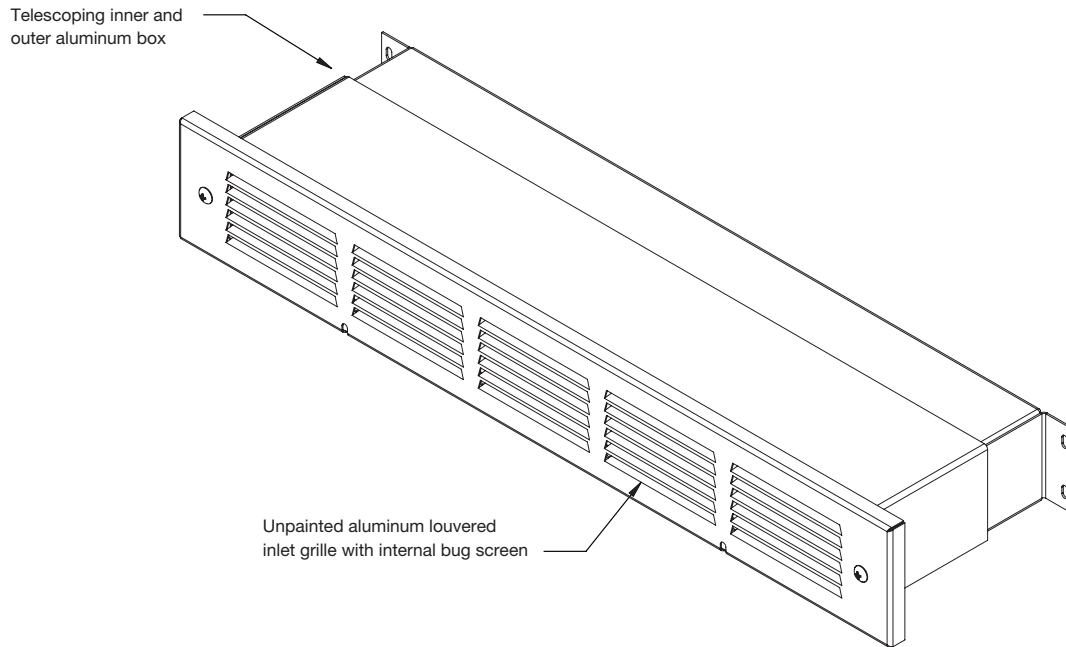

Side View

Dimensional data		
Model	A	Rough opening
WB-0203	24	22-1/2 x 3
WB-0406	29	27-1/2 x 3
WB-081012	39	37-1/2 x 3

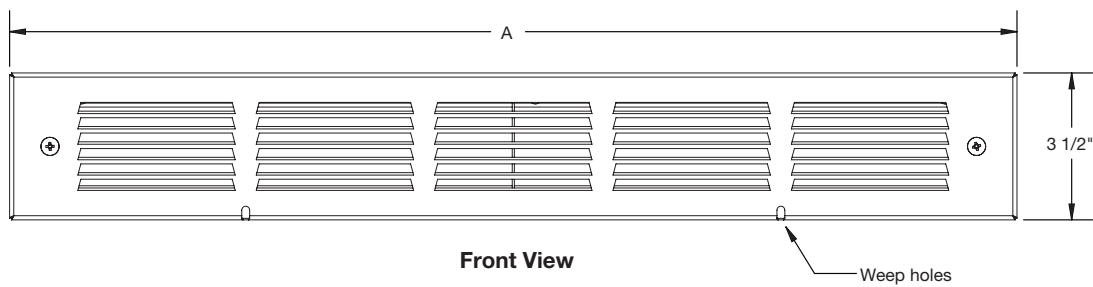

Front View

Weep holes

Dimensions and data

Wall seal kit

Ships loose for field mounting

Front view

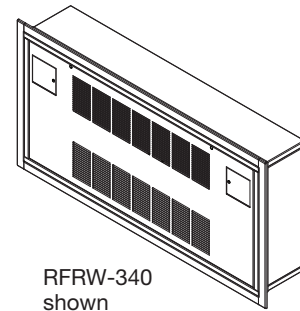
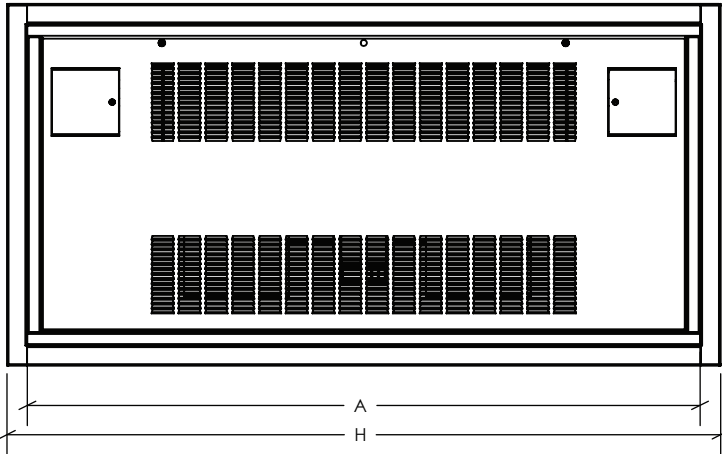

RFRW-340 shown

Top view

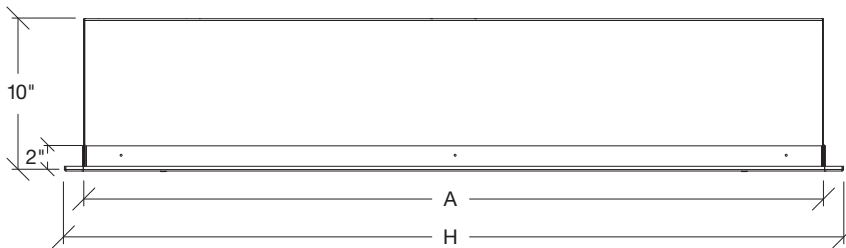

Side view

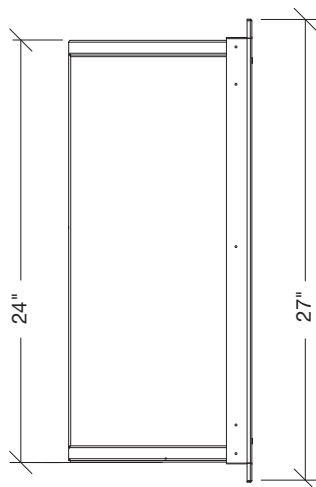

Dimensional data

Unit size	A	H
02	38-3/16	41-3/16
03	44-3/16	47-3/16
04	50-3/16	53-3/16
06	62-3/16	65-3/16
08	68-3/16	71-3/16
10	76-3/16	79-3/16
12	86-3/16	89-3/16

- For fully recessed units locate frame flush with front
- For partially recessed units locate frame as needed
- Use sheet metal screws (by others) to secure trimframe to the unit.

Mechanical Specifications

General

- Furnish and install Cabinet Unit Heaters where indicated on the plans and in the specifications, with required mounting components and accessories. All units shall be capable of meeting or exceeding the scheduled capacities for heating and air delivery. Units shall be ETL certified for the United States and Canada in compliance with UL/ANSI Standard 1995 and CSA C22.2 No. 236-95.

Construction

- All unit chassis shall be fabricated of 20-gauge galvanized steel panels. [Insulation must meet all requirements of ASTM C1071 (including C665), UL 181 for erosion, and carry a 25/50 rating for flame spread/smoke developed per ASTM E-84, UL 723 and NFPA 90A.]
- All exposed units shall have exterior front, top and end panels fabricated of not less than 16-gauge cold rolled steel [14-gauge steel]. The front panel shall be attached with tamper-proof Allen-head quarter turn fasteners to allow for easy removal and access for service. The front panel shall be hinged providing full swing through 90° including removable safety chain(s) to prevent the panel from swinging fully open accidentally (RC, RFRC, RRC). Side panels shall be removable for access to controls and piping within the end pockets, if required. End pockets shall be no less than 8" [extended end pockets shall be no less than 14"] in width, located on both sides of the unit.
- [Provide a grille in the return air opening (RF, RFI, RS, RSI).]
- All exposed units shall include a recessed stamped louver discharge grille. Louver discharge grille shall be reverse stamped, leaving a

Flush-mounted, quarter-turn tamper-resistant fasteners included as standard



smooth exterior surface. [Provide an architectural aluminum double deflection discharge grille with a powder coated paint finish to match cabinet color. Liquid coat paint shall not be acceptable.] [Provide an architectural aluminum bar grille.]

- Louvered panel shall be supplied with two flush, hinged access doors with slotted cam-lock fasteners. [tamper-proof Allen-head security quarter turn fasteners.]
- Recessed units shall be provided with a wall/ceiling seal assembly. The assembly shall provide a finished appearance to the wall/ceiling.
- All ducted units shall have a minimum 1" duct collar on the discharge or return.
 - ◆ Option: Adjustable leveling legs, two on each base leg, shall be provided where indicated on drawings or schedules (RF, RFI, RS, RSI).

Painted finish

- All painted cabinet exterior panels shall be finished with a standard ivory epoxy powder coat paint. Optional colors can be selected from the Zehnder Rittling Color Chart. Liquid coat paint shall not be acceptable.
- Custom colors are also available with the submission of a color chip for color match.

Power

- Units shall not exceed scheduled power consumption.

Fan and motor

- Unit fan shall be dynamically balanced, forward curved, DWDI centrifugal type constructed of galvanized steel for corrosion resistance. Motors shall be permanent split-capacitor [electronically commutated high-efficiency, programmable brushless DC], totally enclosed, tap wound for 3-speed, permanently lubricated sleeve bearing, type with automatic reset integral thermal overload protection. High static motors are available for ducted applications. Shaded pole motors are not acceptable. Single speed motors are not acceptable. Prior to shipping, all motors shall be assembled, factory tested and installed in the unit
- The fan/motor assembly shall be removable and serviceable through the front panel. Each fan/motor assembly shall be fastened by no more than 4 screws. [The motors shall have quick connects to allow service and removal without the need for tools.]

Mechanical Specifications

Coils

- All cooling and heating coils shall optimize rows to meet the specified capacity. Coils shall have $\frac{5}{8}$ " OD, $\frac{1}{2}$ " nominal seamless copper tubes and shall be mechanically expanded to provide an efficient, permanent bond between the tube and aluminum fin. Minimum copper tube thickness shall be 0.016".
- Fins shall have high efficiency aluminum surface optimized for heat transfer, air pressure drop and carryover. Minimum fin thickness shall be 0.0045". Lanced fins shall not be acceptable.
- All coils shall be tested at 350 PSIG air pressure under water, and rated for a maximum 300 PSIG working pressure at 200°F. Coils shall be circuited for counter flow to maximize unit efficiency.
- All water coils shall be designed to connect with $\frac{1}{2}$ " nominal pipe connections.
- Coil casing shall be fabricated from galvanized steel [stainless steel].
- Steam coils shall be standard single tube steam type suitable for temperatures above 35°F and 15 PSIG steam pressure.
- All water coils shall be provided with a manual air vent [automatic air vent] fitting to allow for coil venting.

Filters

- All units shall be furnished with a minimum 1" nominal glass fiber throwaway [1" pleated MERV 4] [1" cleanable aluminum mesh] filter.
- Filters shall be tight fitting to prevent air bypass.
- Filters shall be easily removable from the return air opening without the need for tools, unless there is an inlet louvered return provided.

Electrical

- Units shall be furnished with single point power connection. Provide an electrical control board for motor and other electrical terminations using spade connectors. Provide a 3-speed fan control switch with off, high, medium and low speeds.
 - ◆ Option: Provide 24 VAC fan relays with 40 VA transformer as integral part of control board. Fan relays designed to operate in conjunction with factory provided [field provided] 24 V thermostat. Fan relays designed to accept 120, 208, 220, 230, or 277 V input power. Relays shall operate with generic non-digital [digital, non-programmable] [digital, programmable] thermostat designed to control up to three independently energized fan speeds.
 - ◆ Option: Provide a line voltage wall thermostat, shipped loose for remote mounting. Adjustable setpoint dial included.
 - ◆ Option: Provide a remote bulb return air thermostat mounted in the end pocket with remote bulb temperature sensor within the air stream, regulating room air temperature by measuring the return air temperature. Adjustable setpoint dial included.
 - ◆ Option: Provide a line voltage aquastat, shipped loose for remote mounting on the incoming supply piping. Adjustable setpoint dial included.
 - ◆ Option: Provide a line voltage freezestat for coil protection. Adjustable setpoint included.
 - ◆ Option: Provide a service disconnect switch to isolate power from the unit during maintenance.
 - ◆ Option: Provide a manual motor

starter to provide overload protection for the motor.

- ◆ Option: Provide a power supply cord to enable powering of unit from wall outlet.
- Primary internal wiring and testing shall be conducted at the factory. All units shall be shipped with wiring diagrams.

Piping packages

- Provide a standard factory assembled valve piping package to consist of a 2 or 3-way, on/off, motorized electric control valve and two ball isolation valves.
- Control valves shall be piped normally closed to the coil. Control valves shall be wired to junction box or unit mounted thermostat, when provided, through quick connects to allow service and replacement of valves. Maximum entering water temperature on the control valve shall be 200°F, and maximum operating pressure shall be 300 PSIG.
 - ◆ Option: Unions shall be provided to allow easy removal of piping package from unit without the need for brazing or cutting pipe.
 - ◆ Option: Provide 3-wire floating point modulating control valve (fail-in-place), in lieu of standard 2-position control valve with factory assembled valve piping package.
 - ◆ Option: Provide proportional 0-10 VDC modulating control valve, in lieu of standard 2-position control valve with factory assembled valve piping package.
 - ◆ Option: Provide high pressure close-off actuator for 2 or 3-way on/off control valve. Maximum close-off pressure is 75 PSIG.
 - ◆ Option: Provide an adjustable flow control device for each piping package.

Mechanical Specifications

- ◆ Option: Provide a fixed flow control device for each piping package.
- ◆ Option: Provide pressure-temperature ports (P/T) for each piping package to allow measurement across the coil.
- Piping packages shall be completely factory assembled including interconnecting pipe, factory tested for leaks and shipped loose for field installation.
- ◆ Option: Piping package will be shipped factory installed.

Outside air damper

- Provide a manual [two position motorized] outside air single blade damper integral to the unit. [A synchronous motor interlocked with the fan shall open the outside air damper automatically when the fan starts. If there is a loss in power or the blower stops, the damper shall return to a closed position.]
- ◆ Option: Provide aluminum outside air wall box with integral insect screen and weep holes for field installation.

Units shall be manufactured in accordance with ISO 9001:2008 standards established and maintained by Zehnder Rittling.

zehnder

always the
best climate

Always the best climate for

SMART IDEAS

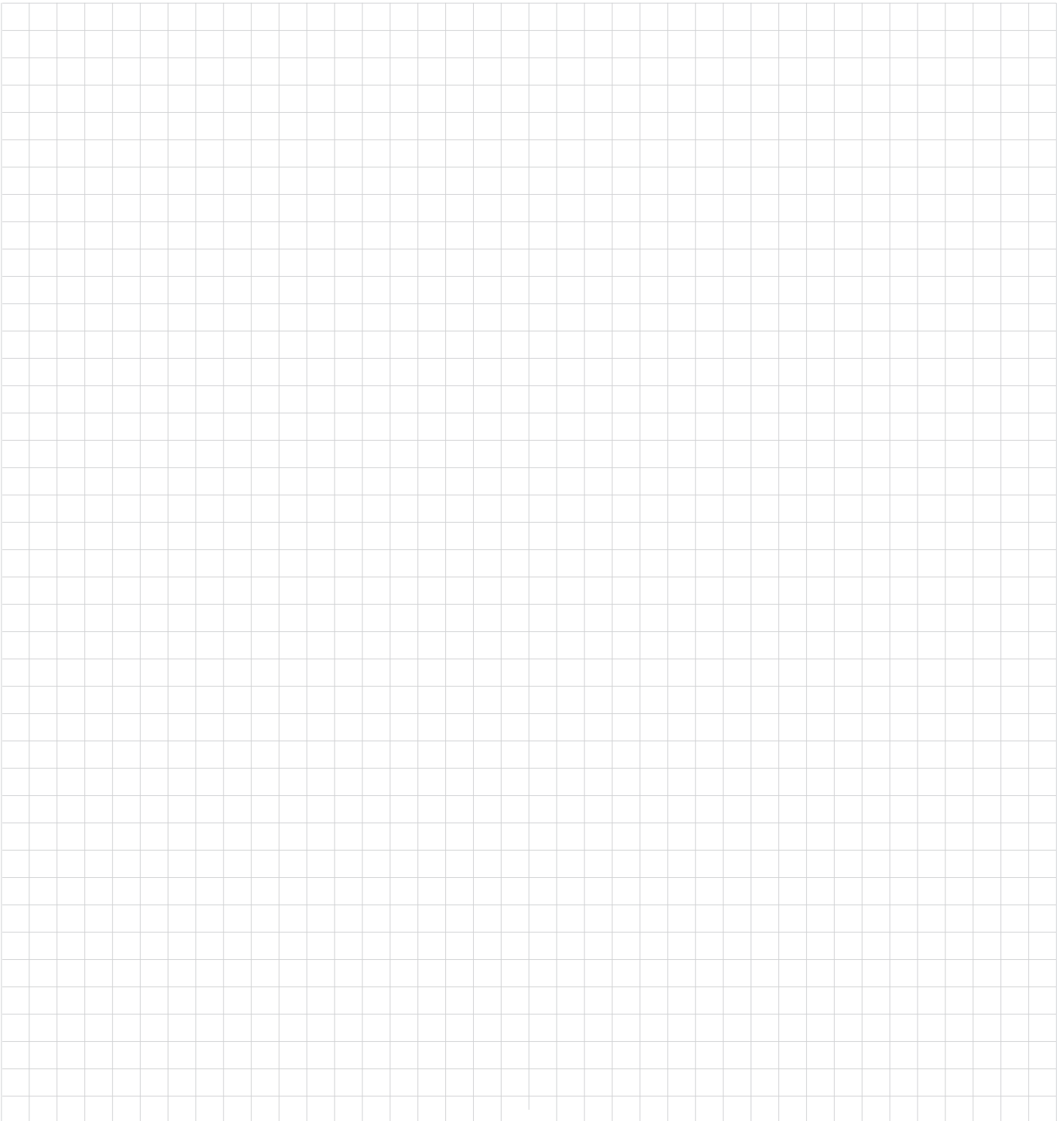

The brand
with the
best indoor
climate
solutions.

The broad and clearly structured portfolio from the Zehnder Group is split into four product lines. Consequently, we can provide the right product, the perfect system and the matching service for all types of projects - from new builds to renovations, single- or multiple- family homes, as well as commercial projects. This variety ensures that our wealth of experience is continuously expanding, providing tangible added value to our customers on a daily basis.



Decorative radiators

Our individual decorative radiators for living and bathrooms not only make a home warmer but also more attractive. Created by renowned designers, they impress with excellent functionality.

NUMBERS THAT SPEAK FOR THEMSELVES

MANUFACTURER OF THE

1ST

STEEL RADIATOR IN
THE WORLD

121

YEARS OF INNOVATIVE TRADITION

AROUND

3,000

EMPLOYEES

FOUNDED IN

1895

REPRESENTED IN
COUNTRIES

19

1,800,000

TONNES OF CO₂ SAVED SINCE 2005

WARRANTY

Zehnder guarantees its products to be free from defects in material and workmanship for a period of two years from date of shipment from our Buffalo, New York factory.

Should there be any defects in the good(s), the purchaser should promptly notify Zehnder. Upon receipt of written consent from Zehnder, the purchaser shall return the defective good(s) to the factory for inspection with freight prepaid. If inspection shows the goods to be defective, Zehnder will at its discretion repair or replace the said item(s).

Defects arising from damage due to shipment, improper installation, negligence or misuse by others are not covered by this warranty.



Comfortable indoor ventilation

Our comfortable indoor ventilation is energy-efficient and provides a healthy indoor climate. It promotes the well-being of the occupants and increases the value of the property.



Heating and cooling ceiling systems

Zehnder heating and cooling ceiling systems are convenient and energy-efficient for heating and cooling. They are perfectly attuned to the relevant environment.



Clean air solutions

Clean air solutions from Zehnder reduce the level of dust in the air, create a healthier working climate and reduce the amount of cleaning required.

BEST CLIMATE IN THE WORLD

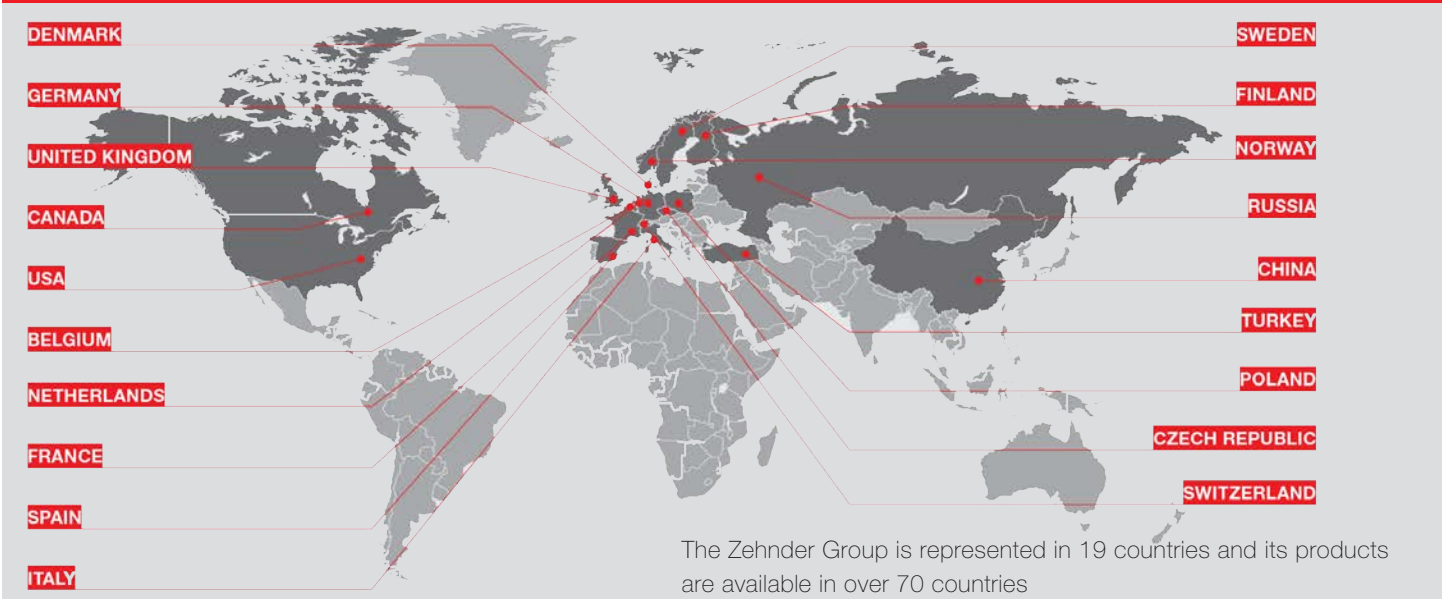

This warranty is extended only to the original purchaser from Zehnder.

IMPORTANT: Approved submittal documentation, specific to each project, supersedes the general guidelines contained within this document.

zehnder

The Zehnder brand offers excellent indoor climate solutions within the sectors of decorative radiators, clean air solutions, comfortable indoor ventilation and heating and cooling ceiling systems.

